

SBD Type : FCH30B10

OUTLINE DRAWING

30A 100V Tj:150°C
FEATURES

- *TO-220AB Case
- *Fully Molded
- *Dual Diodes – Cathode Common
- *Low Forward Voltage Drop
- *High Surge Capability
- *Tj=150 °C operation

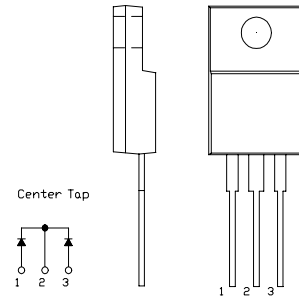

Maximum Ratings

Approx Net Weight: 1.75g

Rating	Symbol	FCH30B10		Unit
Repetitive Peak Reverse Voltage	V_{RRM}	100		V
Average Rectified Output Current	I_O	30	$T_c=97^\circ\text{C}$ 50 Hz Full Sine Wave Resistive Load	A
RMS Forward Current	$I_{F(RMS)}$	33.3		A
Surge Forward Current	I_{FSM}	150	50Hz Full Sine Wave ,1cycle Non-repetitive	A
Operating Junction Temperature Range	T_{jw}	-40 to +150		°C
Storage Temperature Range	T_{stg}	-40 to +150		°C
Mounting torque	F_{tor}	recommended torque = 0.5		N•m

Electrical • Thermal Characteristics

Characteristics	Symbol	Conditions	Min.	Typ.	Max.	Unit
Peak Reverse Current	I_{RM}	$T_j= 25^\circ\text{C}$, $V_{RM}= V_{RRM}$ per Arm	-	-	1	mA
Peak Forward Voltage	V_{FM}	$T_j= 25^\circ\text{C}$, $I_{FM}= 15\text{ A}$ per Arm	-	-	0.96	V
Thermal Resistance	$R_{th(j-c)}$	Junction to Case	-	-	1.5	°C/W
	$R_{th(c-f)}$	Case to Fin	-	-	1.5	°C/W

FCHxxB OUTLINE DRAWING (Dimensions in mm)

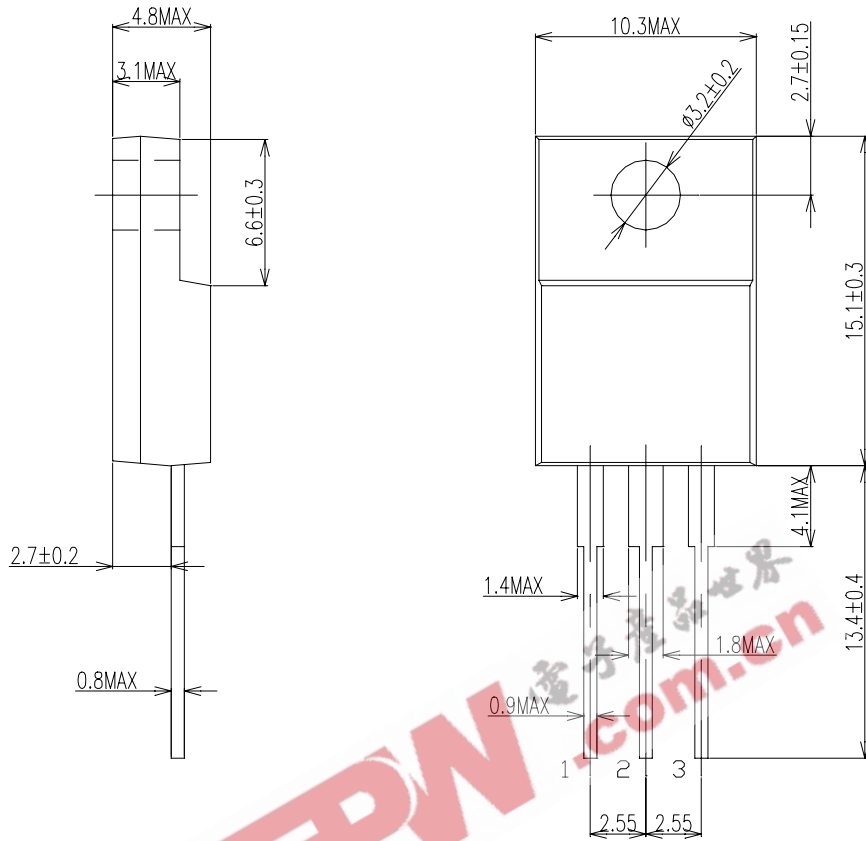

Center Tap

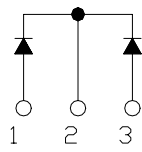

FORWARD CURRENT VS. VOLTAGE

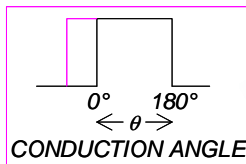
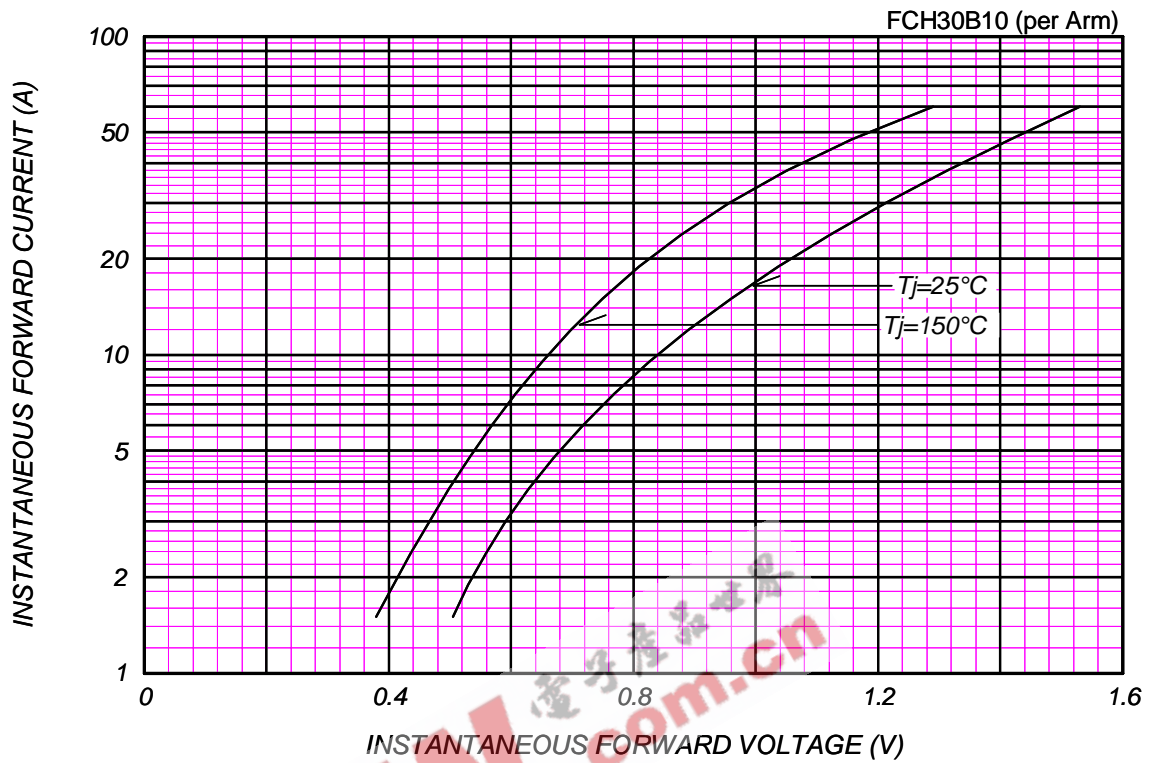

AVERAGE FORWARD POWER DISSIPATION

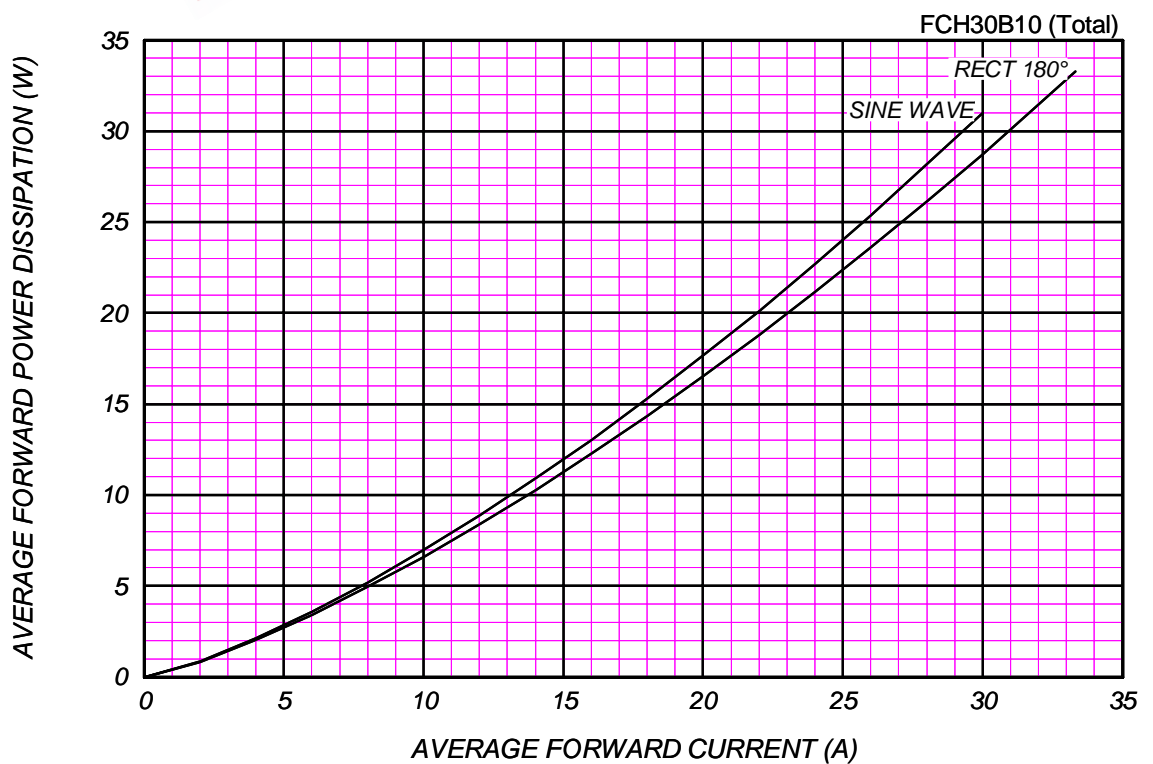

PEAK REVERSE CURRENT VS. PEAK REVERSE VOLTAGE

$T_j = 150\text{ }^\circ\text{C}$

FCH30B10 (per Arm)

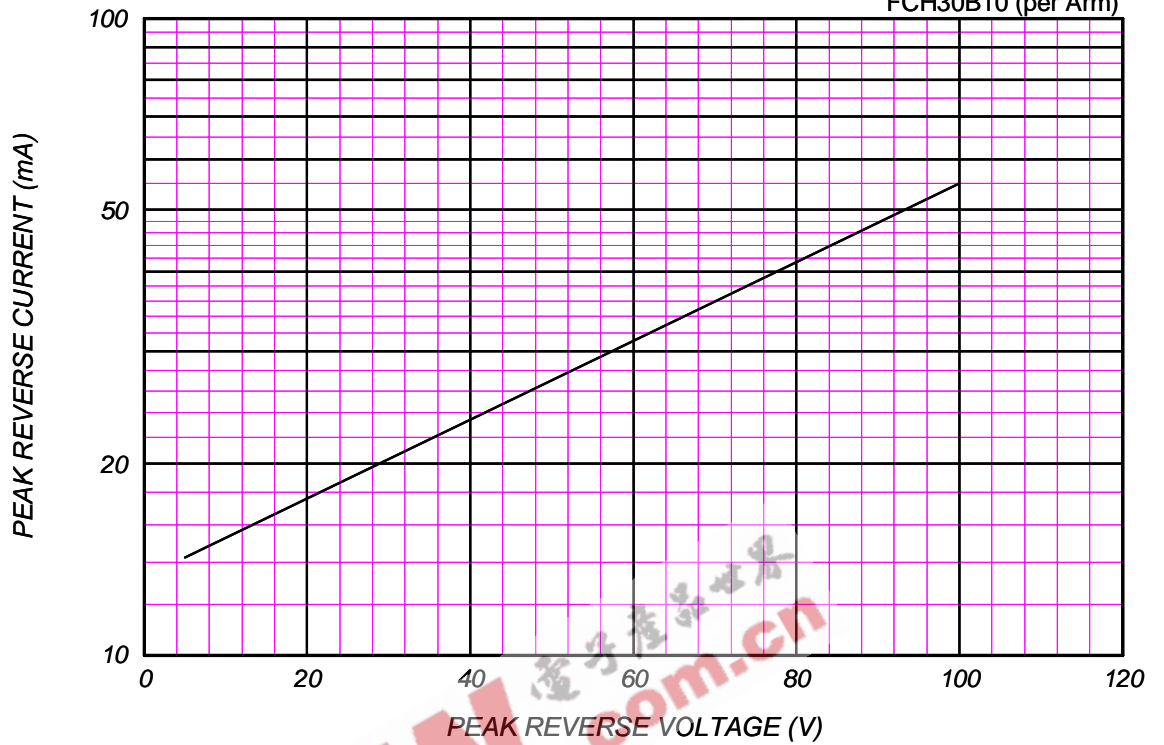

AVERAGE REVERSE POWER DISSIPATION

FCH30B10 (Total)

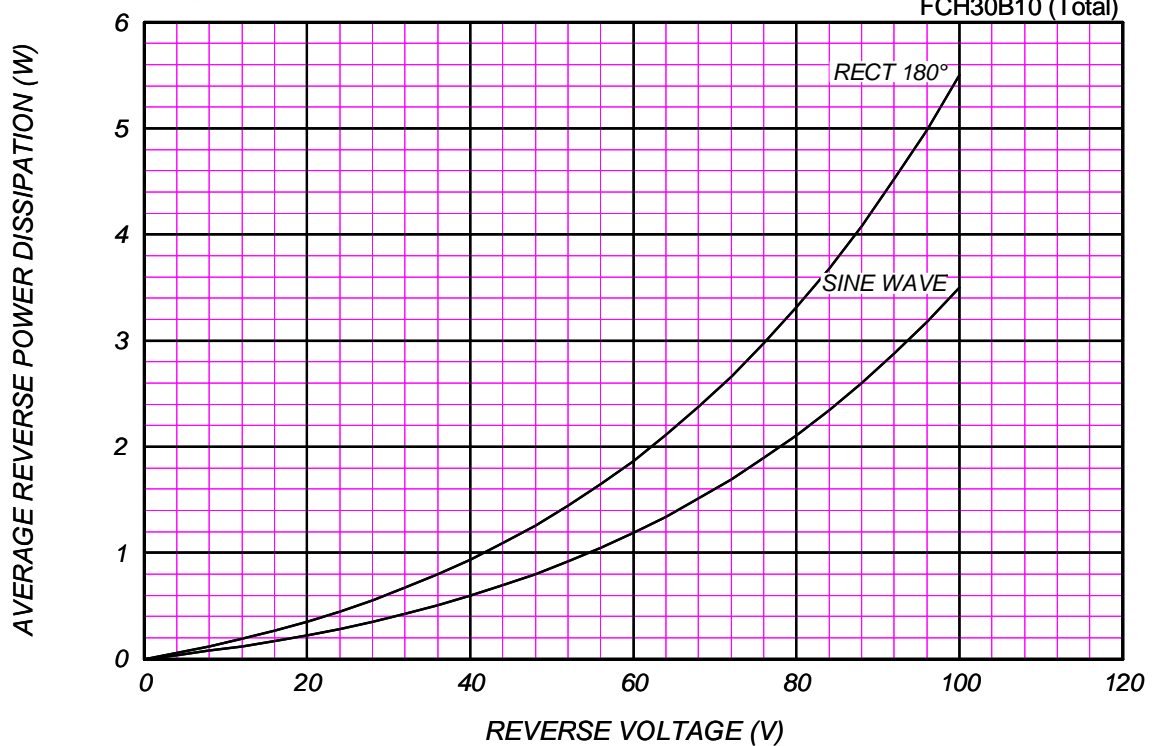

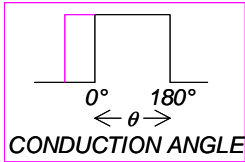

AVERAGE FORWARD CURRENT VS. CASE TEMPERATURE

$V_{RM}=100V$

FCH30B10 (Total)

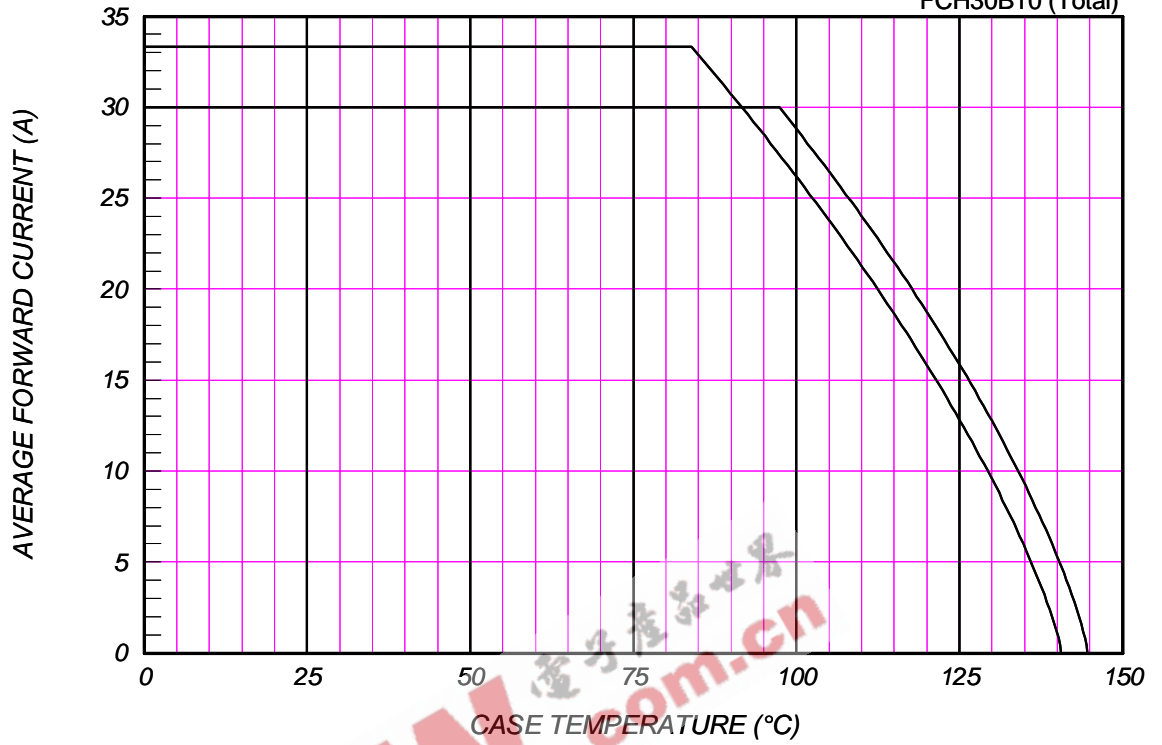

SURGE CURRENT RATINGS

f=50Hz, Sine Wave, Non-Repetitive, No Load

FCH30B10

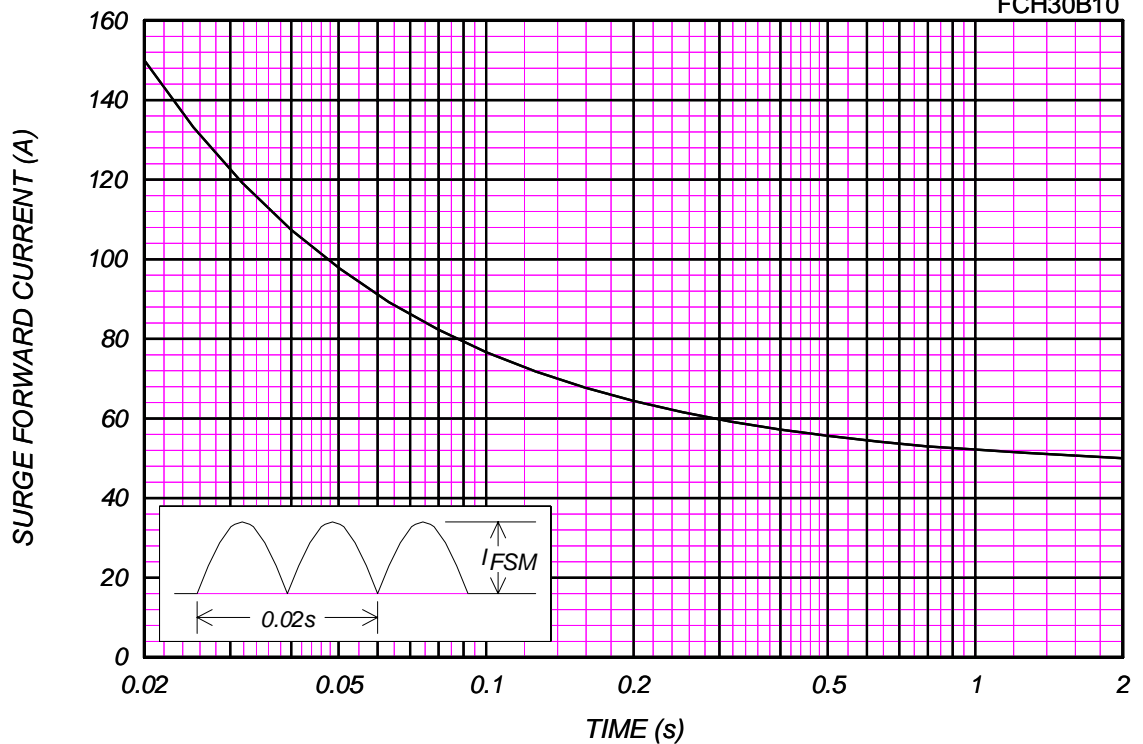

JUNCTION CAPACITANCE VS. REVERSE VOLTAGE

$T_j=25^{\circ}\text{C}$, $V_m=20\text{mV}_{\text{RMS}}$, $f=100\text{kHz}$, Typical Value

FCH30B10 (per Arm)

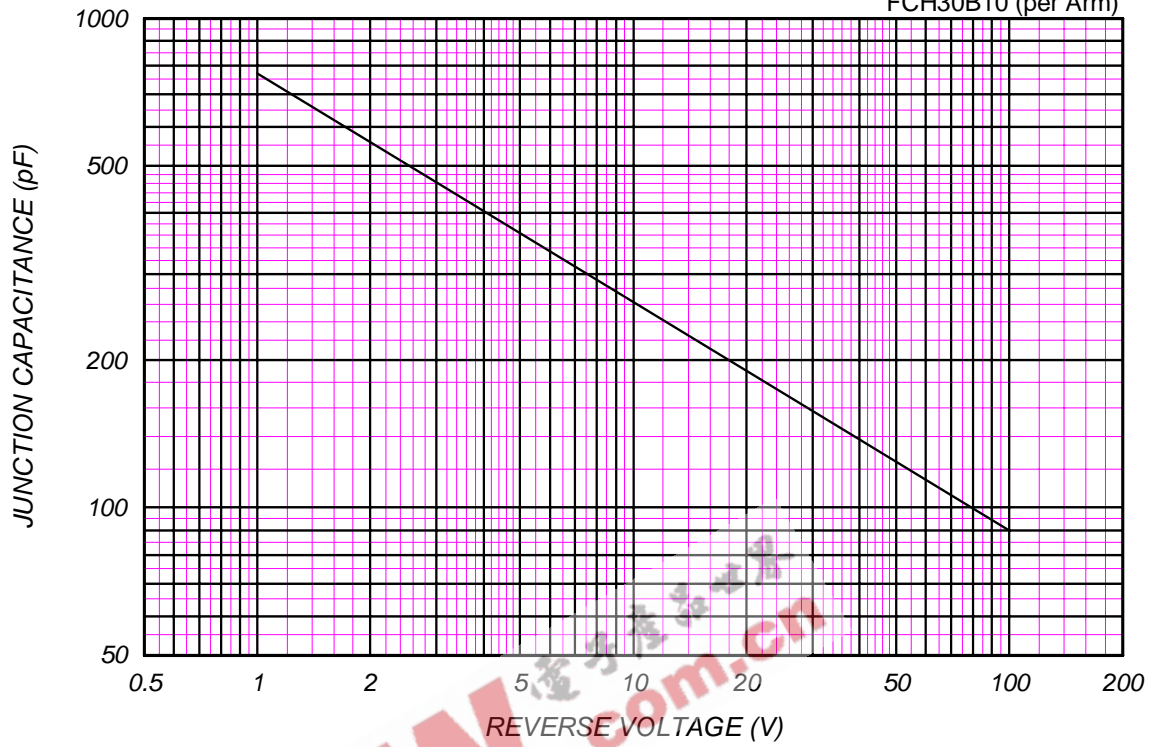

EEPW.com.cn