

QUAD TRUE/COMPLEMENT BUFFER

- BALANCED SINK AND SOURCE CURRENT ; APPROXIMATELY 4 TIMES STANDARD "B" DRIVE
- EQUALIZED DELAY TO TRUE AND COMPLEMENT OUTPUTS
- QUIESCENT CURRENT SPECIFIED TO 20V FOR HCC DEVICE
- 5V, 10V AND 15V PARAMETRIC RATINGS
- INPUT CURRENT OF 100nA AT 18V AND 25°C FOR HCC DEVICE
- 100 % TESTED FOR QUIESCENT CURRENT
- MEETS ALL REQUIREMENTS OF JEDEC TENTATIVE STANDARD N° 13A, "STANDARD SPECIFICATIONS FOR DESCRIPTION OF "B" SERIES CMOS DEVICES"

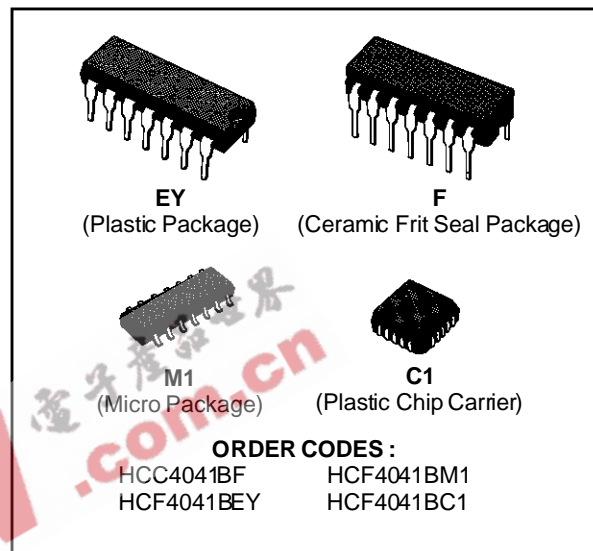

DESCRIPTION

The **HCC4041UB** (extended temperature range) and **HCF4041UB** (intermediate temperature range) are monolithic integrated circuits, available in 14-lead dual in-line plastic or ceramic package and plastic micro package.

The **HCC/HCF4041UB** types are quad true/complement buffers consisting of n- and p-channel units having low channel resistance and high current (sourcing and sinking) capability. The **HCC/HCF4041UB** is intended for use as a buffer, line driver, or COS/MOS-to-TTL driver. It can be used as an ultra-low power resistor-network driver for A/D and D/A conversion, as a transmission-line driver, and in other applications where high noise immunity and low-power dissipation are primary design requirements.

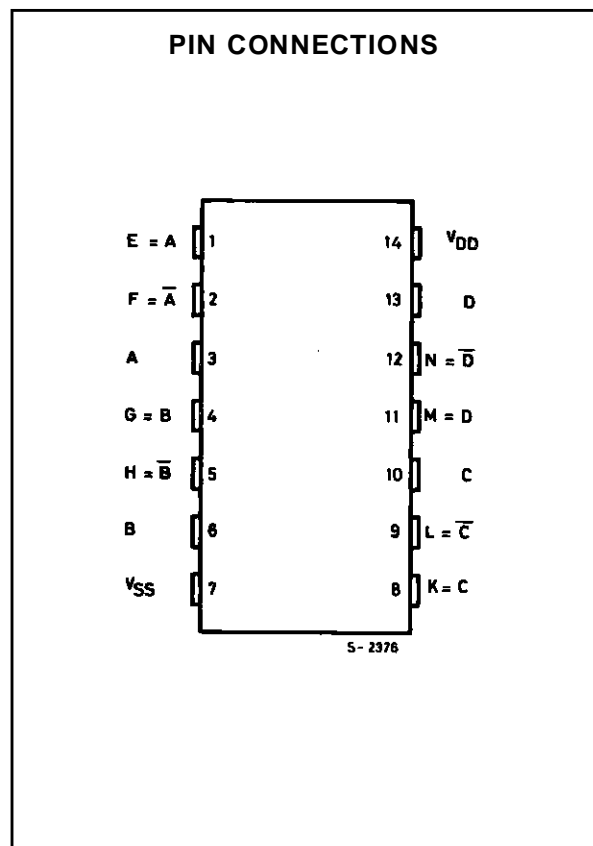

HCC/HCF4041UB

FUNCTIONAL DIAGRAM

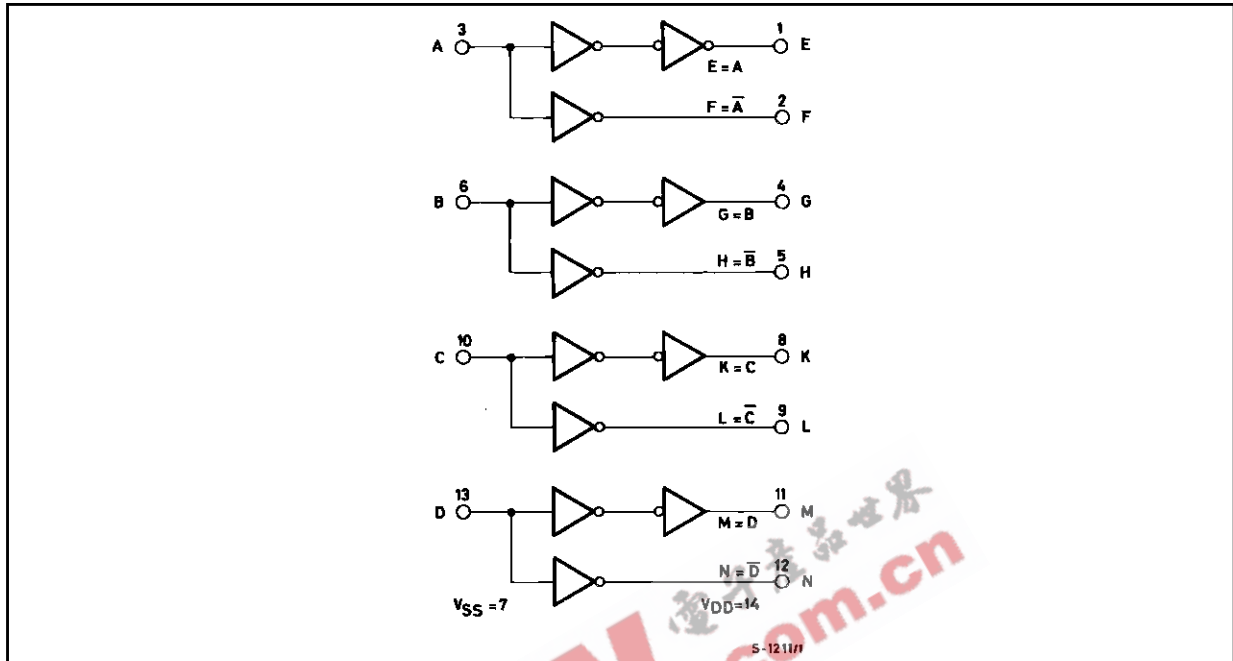

ABSOLUTE MAXIMUM RATINGS

Symbol	Parameter	Value	Unit
V _{DD} *	Supply Voltage : HCC Types HCF Types	- 0.5 to + 20 - 0.5 to + 18	V V
V _i	Input Voltage	- 0.5 to V _{DD} + 0.5	V
I _I	DC Input Current (any one input)	± 10	mA
P _{tot}	Total Power Dissipation (per package) Dissipation per Output Transistor for T _{op} = Full Package-temperature Range	200 100	mW mW
T _{op}	Operating Temperature : HCC Types HCF Types	- 55 to + 125 - 40 to + 85	°C °C
T _{stg}	Storage Temperature	- 65 to + 150	°C

Stresses above those listed under "Absolute Maximum Ratings" may cause permanent damage to the device. This is a stress rating only and functional operation of the device at these or any other conditions above those indicated in the operational sections of this specification is not implied. Exposure to absolute maximum rating conditions for external periods may affect device reliability.

* All voltage values are referred to V_{SS} pin voltage.

RECOMMENDED OPERATING CONDITIONS

Symbol	Parameter	Value	Unit
V _{DD}	Supply Voltage : HCC Types HCF Types	3 to + 18 3 to + 15	V V
V _I	Input Voltage	0 to V _{DD}	V
T _{op}	Operating Temperature : HCC Types HCF Types	- 55 to + 125 - 40 to + 85	°C °C

SCHEMATIC DIAGRAM

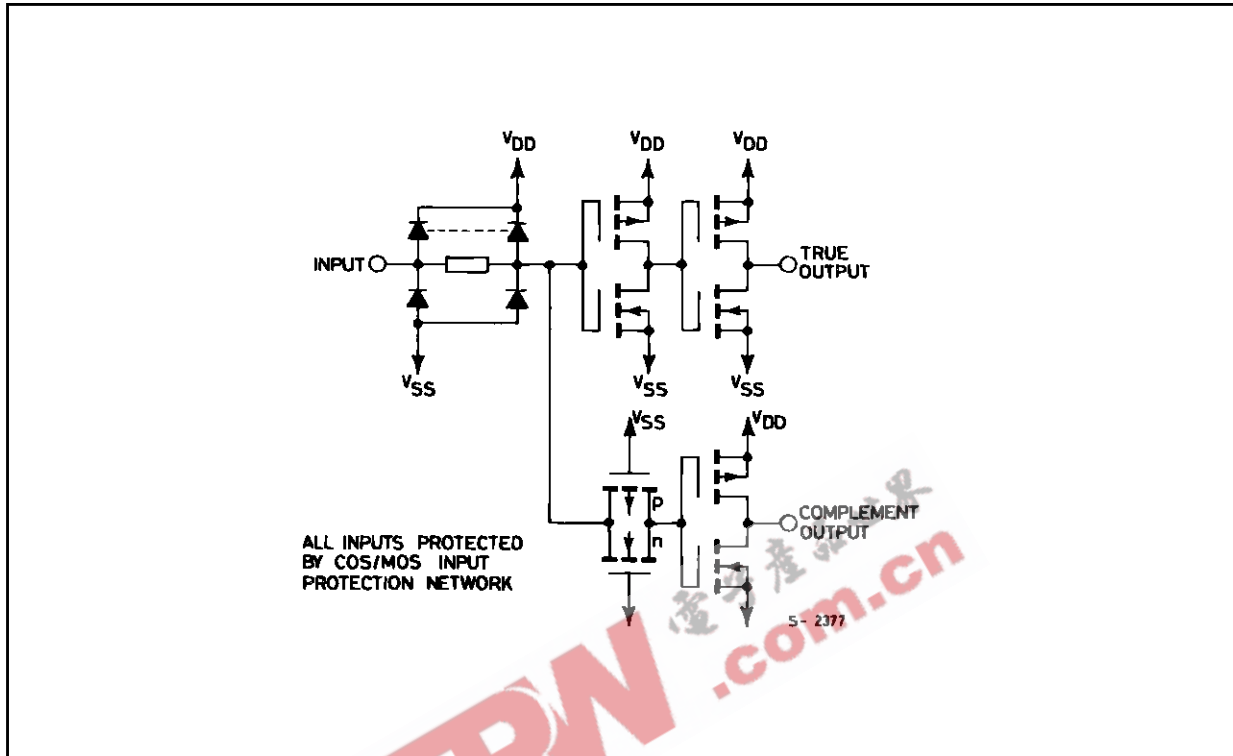

STATIC ELECTRICAL CHARACTERISTICS (over recommended operating conditions)

Symbol	Parameter	Test Conditions				Value						Unit													
		V _I (V)	V _O (V)	I _O (μA)	V _{DD} (V)	T _{Low} *		25°C			T _{High} *														
						Min.	Max.	Min.	Typ.	Max.	Min.		Max.												
I _L	Quiescent Current				5		1		0.02	1		30	μA												
														HCC Types	0/5			10		2		0.02	2		60
															0/10			15		4		0.02	4		120
															0/20			20		20		0.04	20		600
															0/5			5		4		0.02	4		30
														HCF Types	0/10			10		8		0.02	8		60
0/15			15		16		0.02	16		120															
V _{OH}	Output High Voltage	0/5		< 1	5	4.95		4.95		4.95		V													
V _{OL}	Output Low Voltage		5/0		< 1	5		0.05		0.05		0.05	V												
														10/0		< 1	10		0.05		0.05		0.05		
														15/0		< 1	15		0.05		0.05		0.05		
V _{IH}	Input High Voltage		0.5/4.5	< 1	5	4		4			4		V												
														1/9		< 1	10		8		8		8		
														1.5/13.5		< 1	15		12.5		12.5		12.5		

* T_{Low} = - 55°C for HCC device : - 40°C for HCF device.

* T_{High} = + 125°C for HCC device : + 85°C for HCF device.

The Noise Margin for both "1" and "0" level is : 1V min. with V_{DD} = 5V, 2V min. with V_{DD} = 10V, 2.5V min. with V_{DD} = 15V.

HCC/HCF4041UB

STATIC ELECTRICAL CHARACTERISTICS (continued)

Symbol	Parameter	Test Conditions				Value						Unit	
		V _I (V)	V _O (V)	I _O (μ A)	V _{DD} (V)	T _{Low} *		25°C			T _{High} *		
						Min.	Max.	Min.	Typ.	Max.	Min.		Max.
V _{IL}	Input Low Voltage	4.5/0.5	< 1	5		1			1		1	V	
		9/1	< 1	10		2			2		2		
		13.5/1.5	< 1	15		2.5			2.5		2.5		
I _{OH}	Output Drive Current	HCC Types	0/ 5	2.5	5	- 8.4		- 6.4	- 12.8		- 4.6	mA	
			0/ 5	4.6	5	- 2.1		- 1.6	- 3.2		- 1.2		
			0/10	9.5	10	- 6.25		- 5	- 10		- 3.5		
			0/15	13.5	15	- 24		- 19	- 38		- 13		
		HCF Types	0/ 5	2.5	5	- 6.8		- 5.44	- 12.8		- 4.08		
			0/ 5	4.6	5	- 1.7		- 1.36	- 3.2		- 1.02		
			0/10	9.5	10	- 5.31		- 4.25	- 10		- 3.18		
			0/15	13.5	15	-20.18		-16.15	-38		-12.11		
I _{OL}	Output Sink Current	HCC Types	0/ 5	0.4	5	2.1		1.6	3.2		1.2		
			0/10	0.5	10	6.25		5	10		3.5		
			0/15	1.5	15	24		19	38		13		
		HCF Types	0/ 5	0.4	5	1.7		1.36	3.2		1.02		
			0/10	0.5	10	5.31		4.25	10		3.18		
			0/15	1.5	15	20.18		16.15	38		12.11		
I _{IH} , I _{IL}	Input leakage Current	HCC Types	0/18	Any Input	18		± 0.1		$\pm 10^{-5}$	± 0.1		± 1	μ A
		HCF Types	0/15		15		± 0.3		$\pm 10^{-5}$	± 0.3		± 1	
C _I	Input Capacitance	Any Input						15	22.5			pF	

* T_{Low} = - 55°C for HCC device : - 40°C for HCF device.

* T_{High} = + 125°C for HCC device : + 85°C for HCF device.

The Noise Margin for both "1" and "0" level is : 1V min. with V_{DD} = 5V, 2V min. with V_{DD} = 10V, 2.5V min. with V_{DD} = 15V.

DYNAMIC ELECTRICAL CHARACTERISTICS (T_{amb} = 25°C, C_L = 50pF, R_L = 200k Ω , typical temperature coefficient for all V_{DD} values is 0.3 %/°C, all input rise and fall times = 20ns)

Symbol	Parameter	Test Conditions		Value			Unit
			V _{DD} (V)	Min.	Typ.	Max.	
t _{PLH} , t _{PHL}	Propagation Delay Time		5		60	120	ns
			10		35	70	
			15		25	50	
t _{THL} , t _{TLH}	Transition Time		5		40	80	ns
			10		20	40	
			15		15	30	

Minimum Output High (source) Current Characteristics.

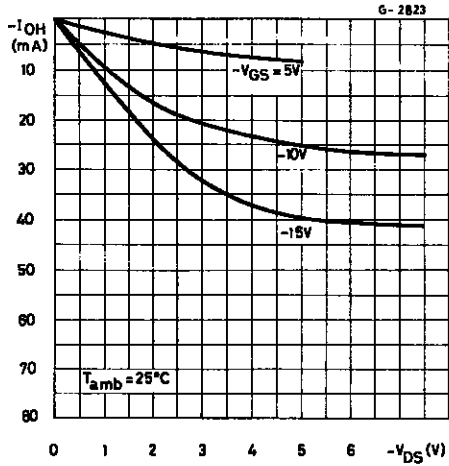

Typical Output Low (sink) Current.

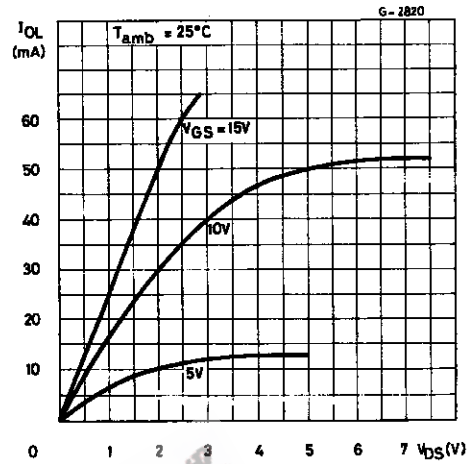

Minimum Output Low (sink) Current Characteristics.

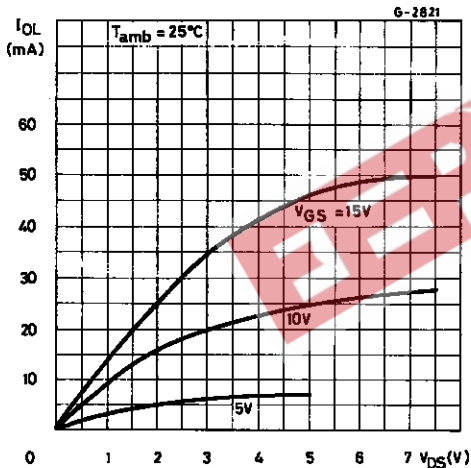

Typical Output High (source) Current Characteristics.

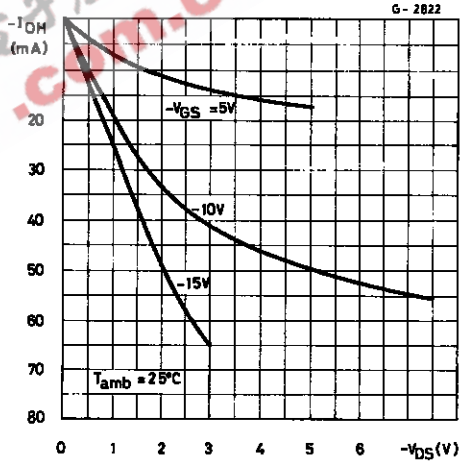

Typical Transition Time vs. Load Capacitance.

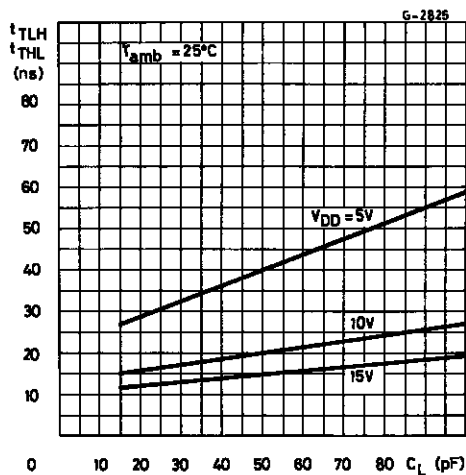

Typical Propagation Delay Time vs. Load Capacitance.

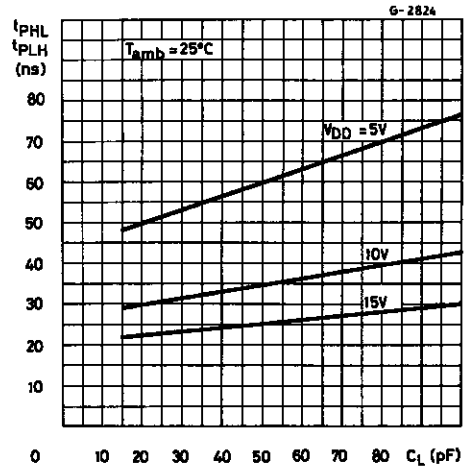

HCC/HCF4041UB

Minimum and Maximum Transfer Characteristics-true Output-and Test Circuit.

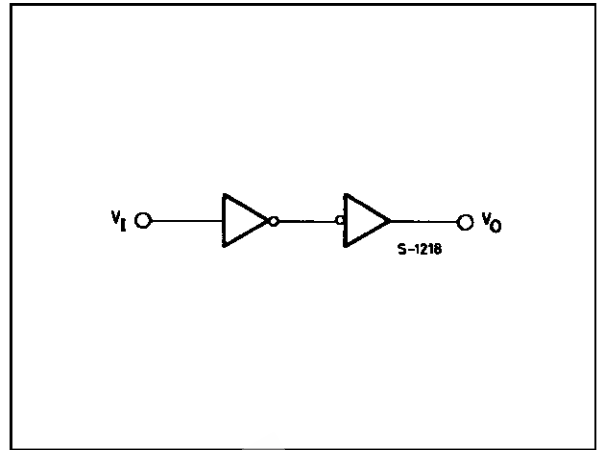
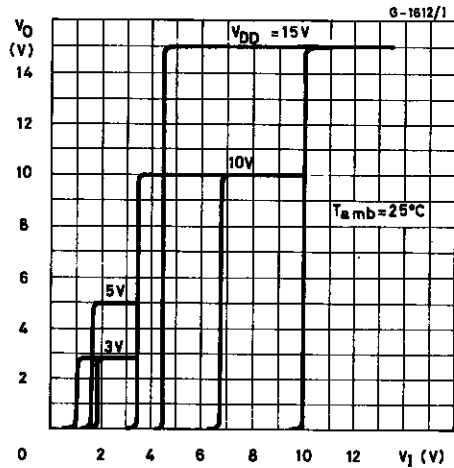

Minimum Maximum Transfer Characteristics Complement Output-and Test Circuit.

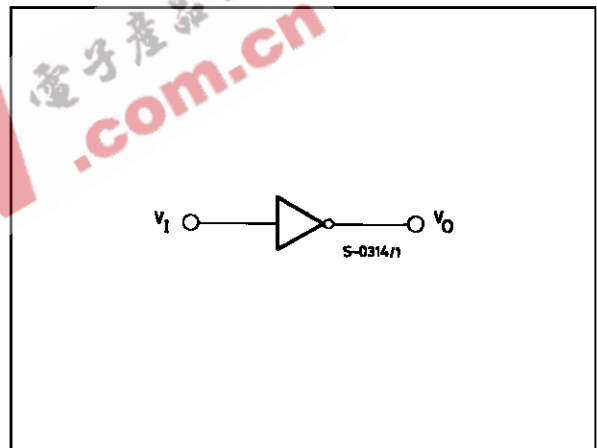
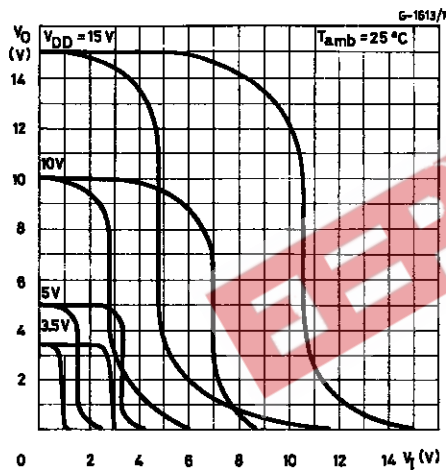

Typical Power Dissipation vs. Input Rise and Fall Time per Output Pair.

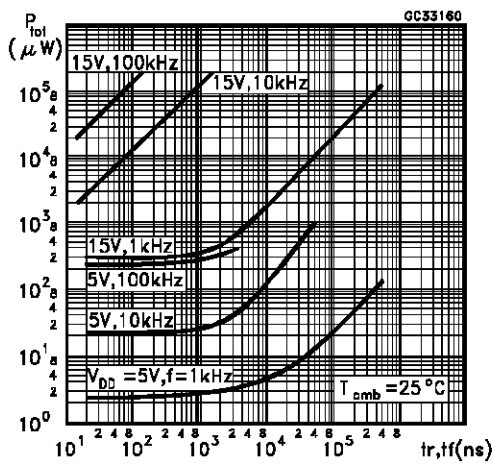

Typical Power Dissipation vs. Frequency per Output Pair.

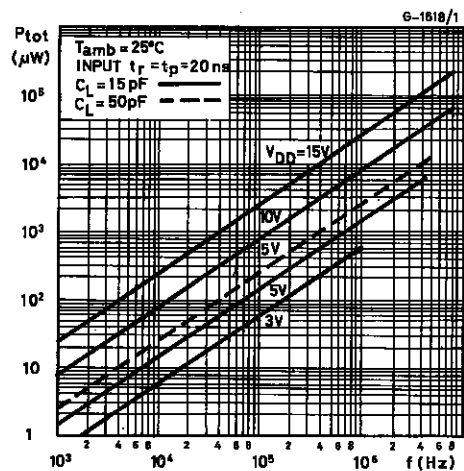

TEST CIRCUITS

Quiescent Device Current.

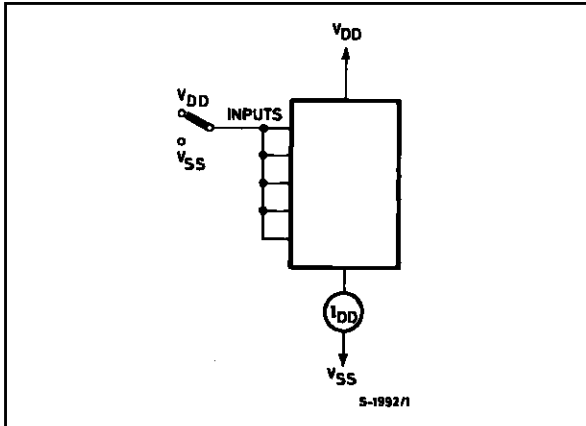

Noise Immunity.

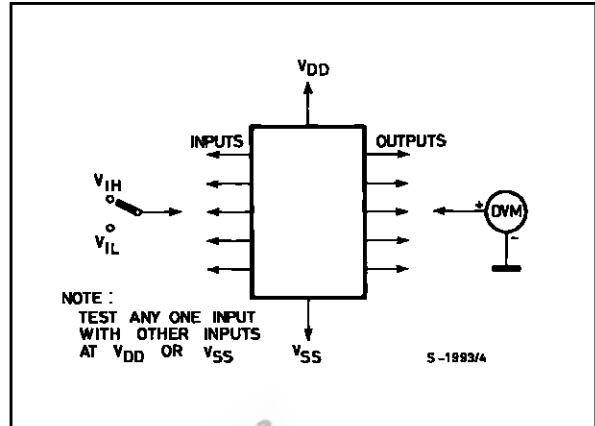

Input Leakage Current.

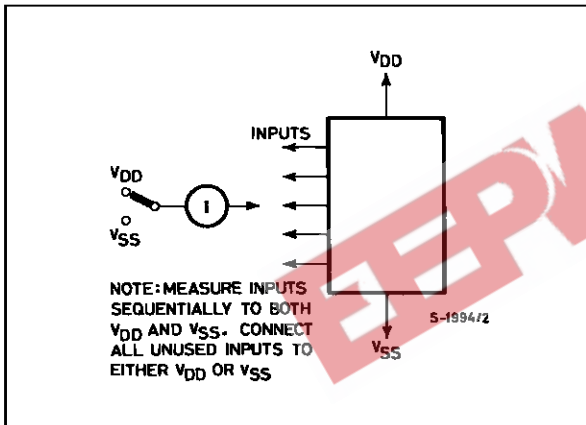

HCC/HCF4041UB

Plastic DIP14 MECHANICAL DATA

DIM.	mm			inch		
	MIN.	TYP.	MAX.	MIN.	TYP.	MAX.
a1	0.51			0.020		
B	1.39		1.65	0.055		0.065
b		0.5			0.020	
b1		0.25			0.010	
D			20			0.787
E		8.5			0.335	
e		2.54			0.100	
e3		15.24			0.600	
F			7.1			0.280
I			5.1			0.201
L		3.3			0.130	
Z	1.27		2.54	0.050		0.100

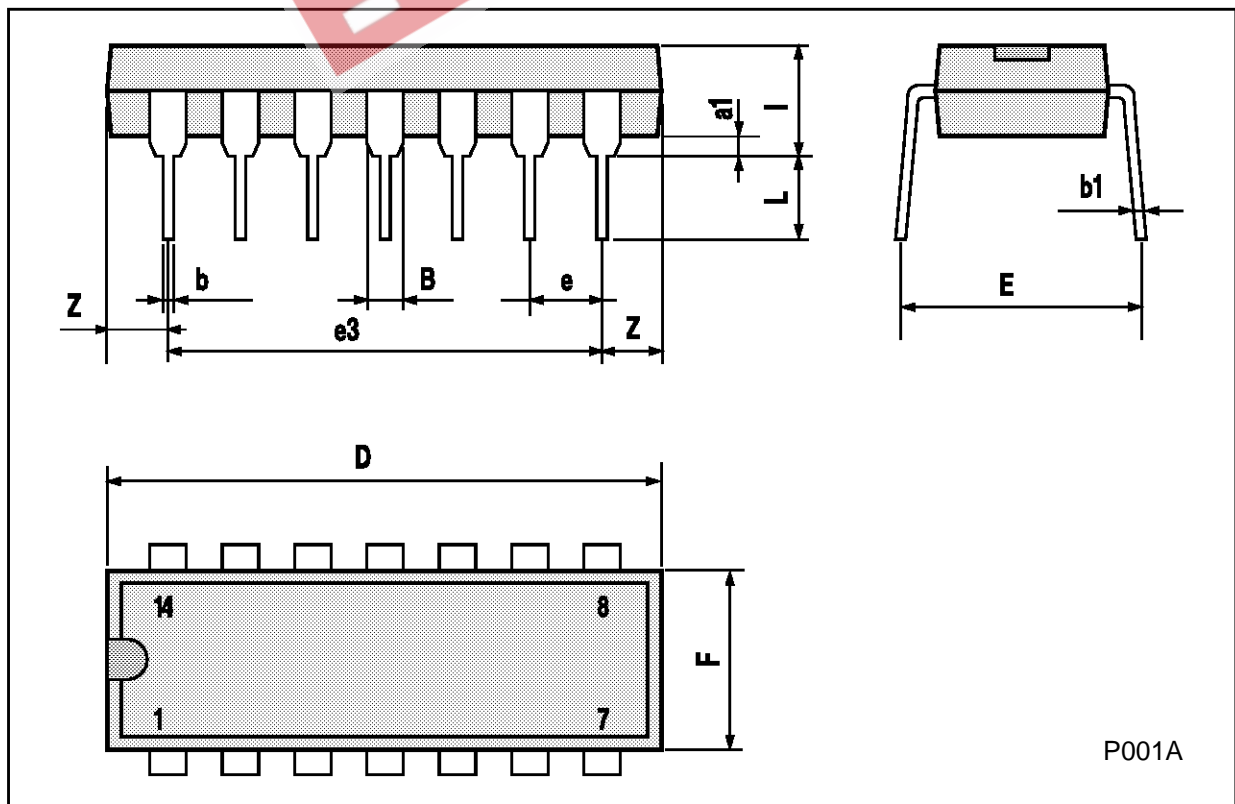

Ceramic DIP14/1 MECHANICAL DATA

DIM.	mm			inch		
	MIN.	TYP.	MAX.	MIN.	TYP.	MAX.
A			20			0.787
B			7.0			0.276
D		3.3			0.130	
E	0.38			0.015		
e3		15.24			0.600	
F	2.29		2.79	0.090		0.110
G	0.4		0.55	0.016		0.022
H	1.17		1.52	0.046		0.060
L	0.22		0.31	0.009		0.012
M	1.52		2.54	0.060		0.100
N			10.3			0.406
P	7.8		8.05	0.307		0.317
Q			5.08			0.200

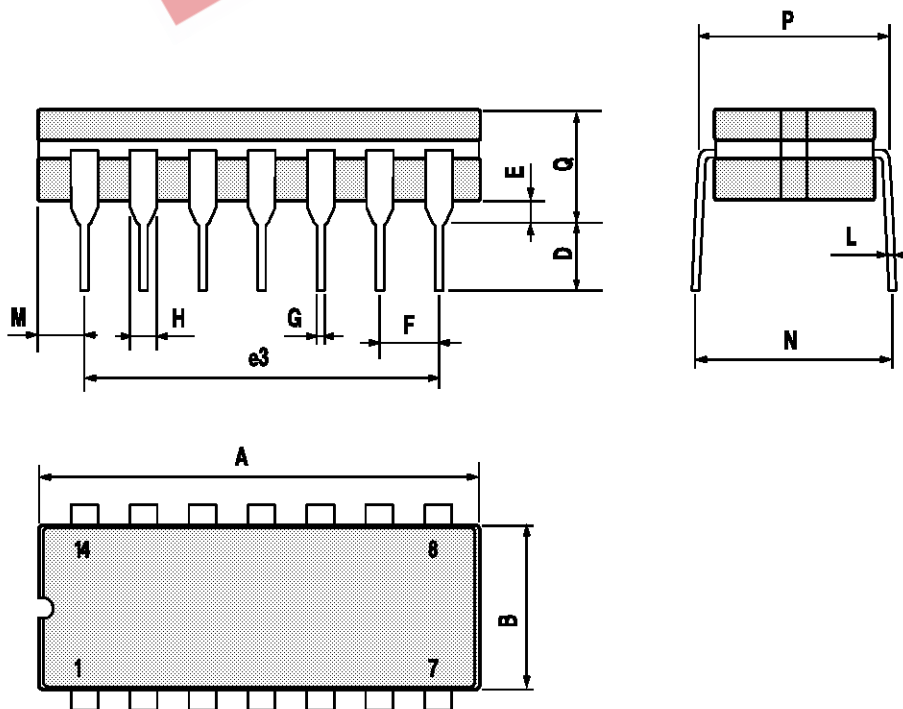

P053C

HCC/HCF4041UB

SO14 MECHANICAL DATA

DIM.	mm			inch		
	MIN.	TYP.	MAX.	MIN.	TYP.	MAX.
A			1.75			0.068
a1	0.1		0.2	0.003		0.007
a2			1.65			0.064
b	0.35		0.46	0.013		0.018
b1	0.19		0.25	0.007		0.010
C		0.5			0.019	
c1	45° (typ.)					
D	8.55		8.75	0.336		0.344
E	5.8		6.2	0.228		0.244
e		1.27			0.050	
e3		7.62			0.300	
F	3.8		4.0	0.149		0.157
G	4.6		5.3	0.181		0.208
L	0.5		1.27	0.019		0.050
M			0.68			0.026
S	8° (max.)					

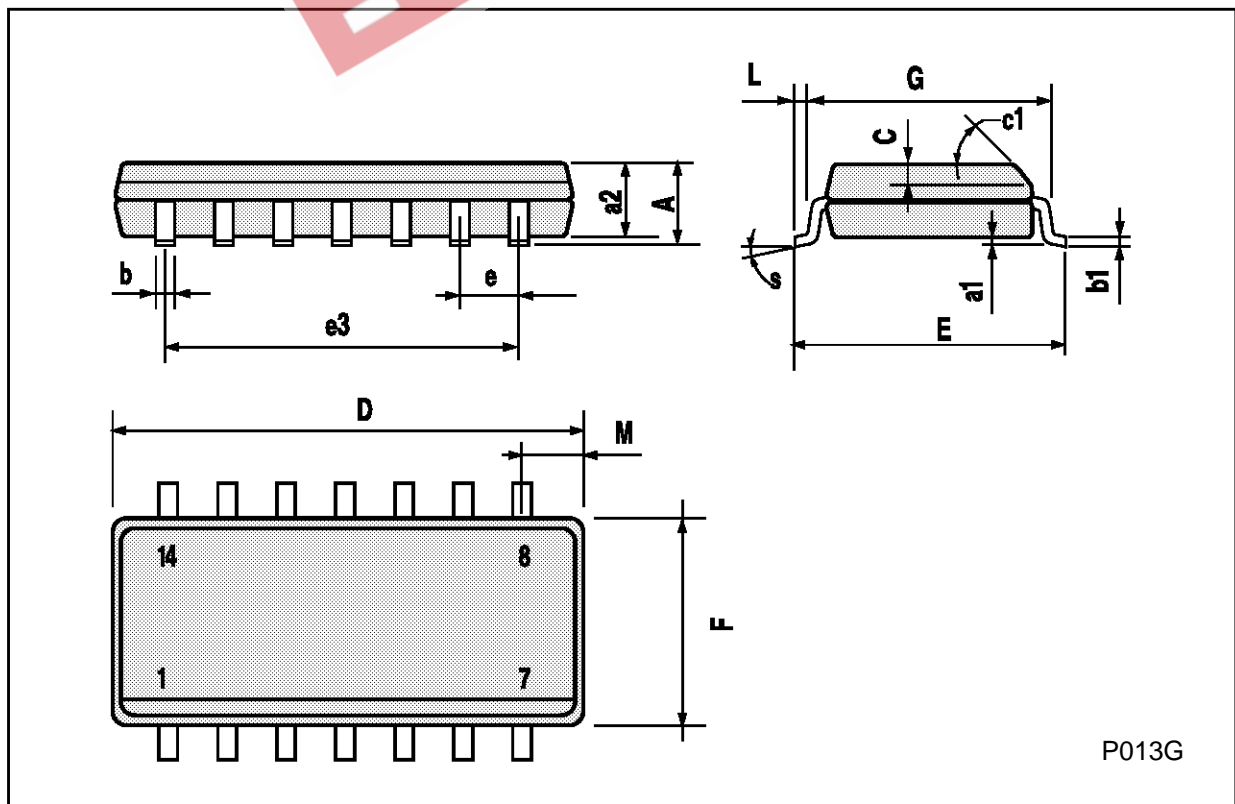

PLCC20 MECHANICAL DATA

DIM.	mm			inch		
	MIN.	TYP.	MAX.	MIN.	TYP.	MAX.
A	9.78		10.03	0.385		0.395
B	8.89		9.04	0.350		0.356
D	4.2		4.57	0.165		0.180
d1		2.54			0.100	
d2		0.56			0.022	
E	7.37		8.38	0.290		0.330
e		1.27			0.050	
e3		5.08			0.200	
F		0.38			0.015	
G			0.101			0.004
M		1.27			0.050	
M1		1.14			0.045	

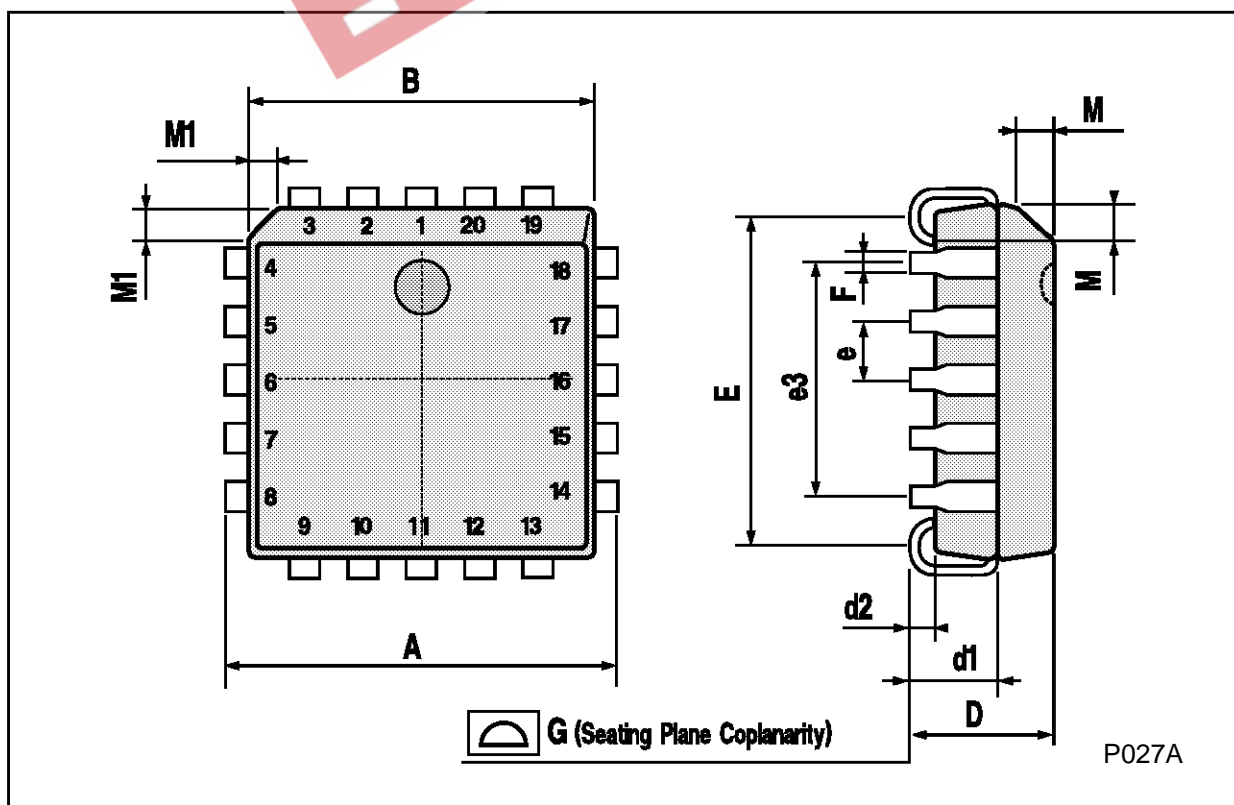

EEPW 电子產品世界
.com.cn

Information furnished is believed to be accurate and reliable. However, SGS-THOMSON Microelectronics assumes no responsibility for the consequences of use of such information nor for any infringement of patents or other rights of third parties which may result from its use. No license is granted by implication or otherwise under any patent or patent rights of SGS-THOMSON Microelectronics. Specifications mentioned in this publication are subject to change without notice. This publication supersedes and replaces all information previously supplied. SGS-THOMSON Microelectronics products are not authorized for use as critical components in life support devices or systems without express written approval of SGS-THOMSON Microelectronics.

© 1994 SGS-THOMSON Microelectronics - All Rights Reserved

SGS-THOMSON Microelectronics GROUP OF COMPANIES
Australia - Brazil - France - Germany - Hong Kong - Italy - Japan - Korea - Malaysia - Malta - Morocco - The Netherlands -
Singapore - Spain - Sweden - Switzerland - Taiwan - Thailand - United Kingdom - U.S.A