

AND GATES

4073B TRIPLE 3-INPUT AND GATE
4081B QUAD 2-INPUT AND GATE
4082B DUAL 4-INPUT AND GATE

- MEDIUM SPEED OPERATION – $t_{PLH} = 85\text{ns}$ (typ.); $t_{PHL} = 65\text{ns}$ (typ.) AT 10V
- QUIESCENT CURRENT SPECIFIED TO 20V FOR HCC DEVICE
- 5V, 10V, AND 15V PARAMETRIC RATINGS
- INPUT CURRENT OF 100nA AT 18V AND 25°C FOR HCC DEVICE
- 100% TESTED FOR QUIESCENT CURRENT
- MEETS ALL REQUIREMENTS OF JEDEC TENTATIVE STANDARD N° 13A, "STANDARD SPECIFICATIONS FOR DESCRIPTION OF "B" SERIES CMOS DEVICES"

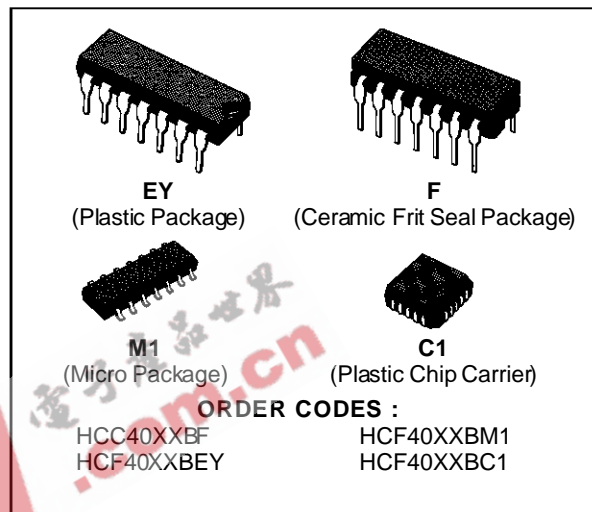

DESCRIPTION

The **HCC4073B**, **HCC4081B** and **HCC4082B** (extended temperature range) and the **HCF4073B**, **HCF4081B** and **HCF4082B** (intermediate temperature range) are monolithic integrated circuits avail-

able in 14-lead dual in-line plastic or ceramic package and plastic micro package.

The **HCC/HCF4073B**, **4081B** and **4082B** AND gates provide the system designer with direct im-

CONNECTION DIAGRAM

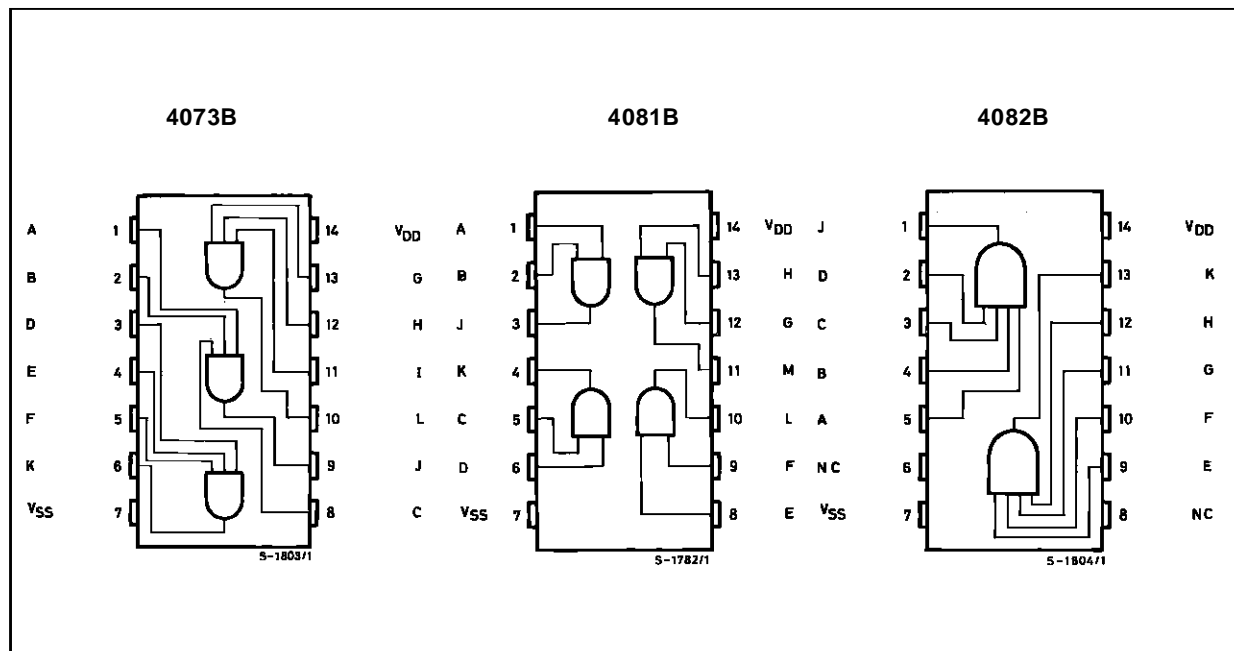

HCC/HCF4073B/4081B/4082B

ABSOLUTE MAXIMUM RATINGS

Symbol	Parameter	Value	Unit
V _{DD} *	Supply Voltage : HCC Types HCF Types	- 0.5 to + 20	V
		- 0.5 to + 18	V
V _i	Input Voltage	- 0.5 to V _{DD} + 0.5	V
I _I	DC Input Current (any one input)	± 10	mA
P _{tot}	Total Power Dissipation (per package) Dissipation per Output Transistor for T _{op} = Full Package-temperature Range	200	mW
		100	mW
T _{op}	Operating Temperature : HCC Types HCF Types	- 55 to + 125	°C
		- 40 to + 85	°C
T _{stg}	Storage Temperature	- 65 to + 150	°C

Stresses above those listed under "Absolute Maximum Ratings" may cause permanent damage to the device. This is a stress rating only and functional operation of the device at these or any other conditions above those indicated in the operational sections of this specification is not implied. Exposure to absolute maximum rating conditions for external periods may affect device reliability.

* All voltage values are referred to V_{SS} pin voltage.

RECOMMENDED OPERATING CONDITIONS

Symbol	Parameter	Value	Unit
V _{DD}	Supply Voltage : HCC Types HCF Types	3 to 18	V
		3 to 15	V
V _I	Input Voltage	0 to V _{DD}	V
T _{op}	Operating Temperature : HCC Types HCF Types	- 55 to + 125	°C
		- 40 to + 85	°C

STATIC ELECTRICAL CHARACTERISTICS (over recommended operating conditions)

Symbol	Parameter	Test Conditions				Value						Unit		
		V _I (V)	V _O (V)	I _O (μA)	V _{DD} (V)	T _{Low} *		25 °C			T _{High} *			
						Min.	Max.	Min.	Typ.	Max.	Min.		Max.	
I _L	Quiescent Current	HCC Types	0/ 5			5		0.25		0.01	0.25		7.5	μA
			0/10			10		0.5		0.01	0.5		15	
			0/15			15		1		0.01	1		30	
			0/20			20		5		0.02	5		150	
		HCF Types	0/ 5			5		1		0.01	1		7.5	
			0/10			10		2		0.01	2		15	
			0/15			15		4		0.01	4		30	
V _{OH}	Output High Voltage	0/ 5		< 1	5	4.95		4.95			4.95		V	
		0/10		< 1	10	9.95		9.95			9.95			
		0/15		< 1	15	14.95		14.95			14.95			
V _{OL}	Output Low Voltage	5/0		< 1	5		0.05			0.05		0.05	V	
		10/0		< 1	10		0.05			0.05		0.05		
		15/0		< 1	15		0.05			0.05		0.05		

* T_{Low} = - 55°C for **HCC** device : - 40°C for **HCF** device.

* T_{High} = + 125°C for **HCC** device : + 85°C for **HCF** device.

The Noise Margin for both "1" and "0" level is : 1V min. with V_{DD} = 5V, 2V min. with V_{DD} = 10V, 2.5V min. with V_{DD} = 15V.

STATIC ELECTRICAL CHARACTERISTICS (continued)

Symbol	Parameter	Test Conditions				Value						Unit	
		V _I (V)	V _O (V)	I _O (μ A)	V _{DD} (V)	T _{Low} *		25 °C			T _{High} *		
						Min.	Max.	Min.	Typ.	Max.	Min.		Max.
V _{IH}	Input High Voltage	0.5/4.5	< 1	5	3.5		3.5			3.5		V	
		1/9	< 1	10	7		7			7			
		1.5/13.5	< 1	15	11		11			11			
V _{IL}	Input Low Voltage	4.5/0.5	< 1	5		1.5			1.5		1.5	V	
		9/1	< 1	10		3			3		3		
		13.5/1.5	< 1	15		4			4		4		
I _{OH}	Output Drive Current	HCC Types	0/ 5	2.5	5	- 2		- 1.6	- 3.2		- 1.15	mA	
			0/ 5	4.6	5	- 0.64		- 0.51	- 1		- 0.36		
			0/10	9.5	10	- 1.6		- 1.3	- 2.6		- 0.9		
			0/15	13.5	15	- 4.2		- 3.4	- 6.8		- 2.4		
		HCF Types	0/ 5	2.5	5	- 1.53		- 1.36	- 3.2		- 1.1		
			0/ 5	4.6	5	- 0.52		- 0.44	- 1		- 0.36		
			0/10	9.5	10	- 1.3		- 1.1	- 2.6		- 0.9		
			0/15	13.5	15	- 3.6		- 3.0	- 6.8		- 2.4		
I _{OL}	Output Sink Current	HCC Types	0/ 5	0.4	5	0.64		0.51	1		0.36	mA	
			0/10	0.5	10	1.6		1.3	2.6		0.9		
			0/15	1.5	15	4.2		3.4	6.8		2.4		
		HCF Types	0/ 5	0.4	5	0.52		0.44	1		0.36		
			0/10	0.5	10	1.3		1.1	2.6		0.9		
			0/15	1.5	15	3.6		3.0	6.8		2.4		
I _{IH} , I _{IL}	Input Leakage Current	HCC Types	0/18	Any Input	18		± 0.1		$\pm 10^{-5}$	± 0.1		± 1	μ A
		HCF Types	0/15		15		± 0.3		$\pm 10^{-5}$	± 0.3		± 1	
C _i	Input Capacitance		Any Input					5	7.5			pF	

* T_{Low} = - 55°C for HCC device : - 40°C for HCF device.* T_{High} = + 125°C for HCC device : + 85°C for HCF device.The Noise Margin for both "1" and "0" level is : 1V min. with V_{DD} = 5V, 2V min. with V_{DD} = 10V, 2.5V min. with V_{DD} = 15V.DYNAMIC ELECTRICAL CHARACTERISTICS (T_{amb} = 25°C, C_L = 50pF, typical temperature coefficient for all V_{DD} values is 0.3%/°C, all input rise and fall times = 20ns, R_L = 200k Ω)

Symbol	Parameter	Test Conditions		Value			Unit
			V _{DD} (V)	Min.	Typ.	Max.	
t _{PHL} , t _{PLH}	Propagation Delay Time		5		125	250	ns
			10		60	125	
			15		45	90	
t _{TLH} , t _{THL}	Transition Time		5		100	200	ns
			10		50	100	
			15		40	80	

HCC/HCF4073B/4081B/4082B

Typical Voltage and Current Transfer Characteristics.

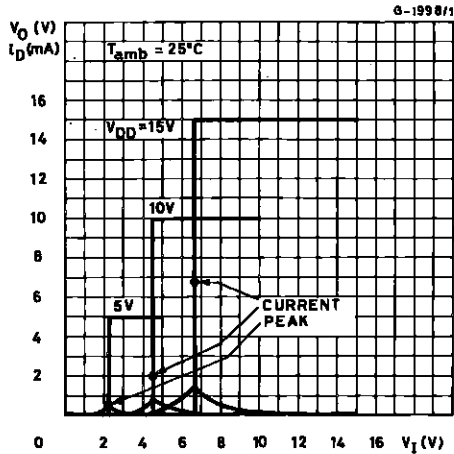

Typical Output Low (sink) Current .

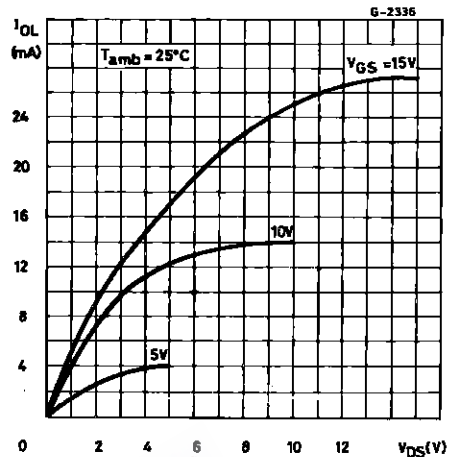

Minimum Output Low (sink) Current Characteristics.

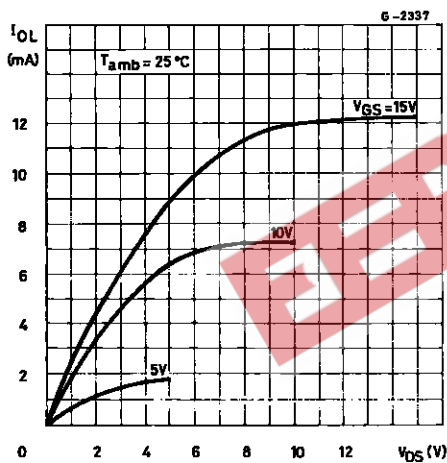

Typical Output High (source) Current Characteristics.

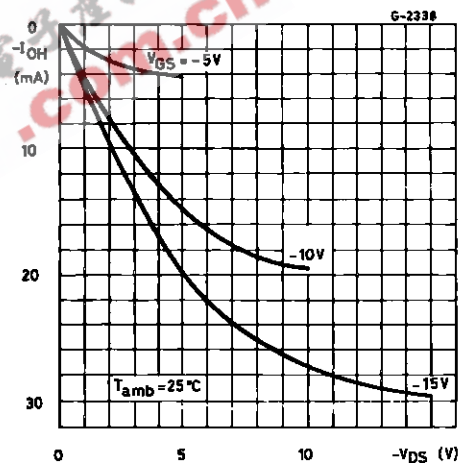

Minimum Output High (source) Current Characteristics.

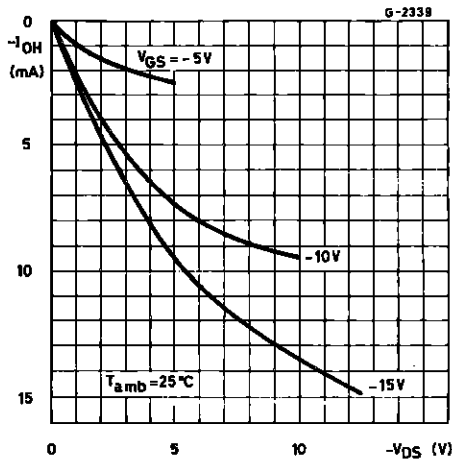

Typical Propagation Delay Time vs. Load Capacitance.

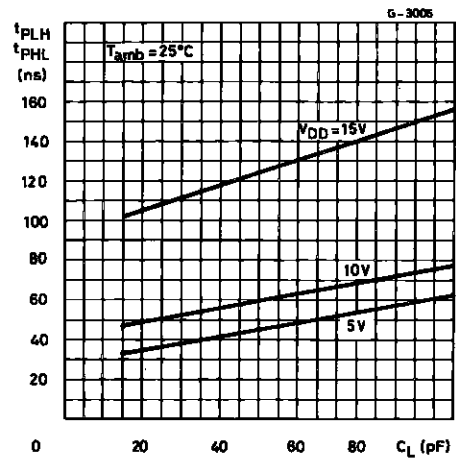

Typical Transition Time vs. Load Capacitance.

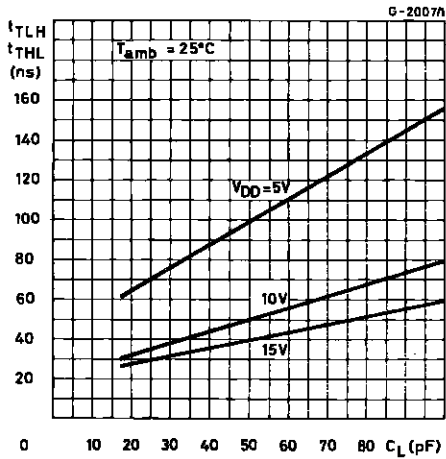

Typical Dynamic Power Dissipation per Gate vs. Frequency.

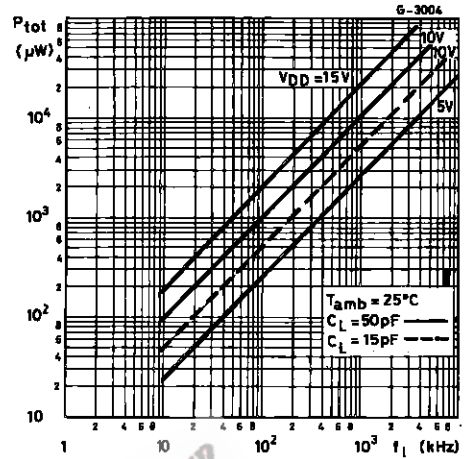

TEST CIRCUITS

Quiescent Device Current.

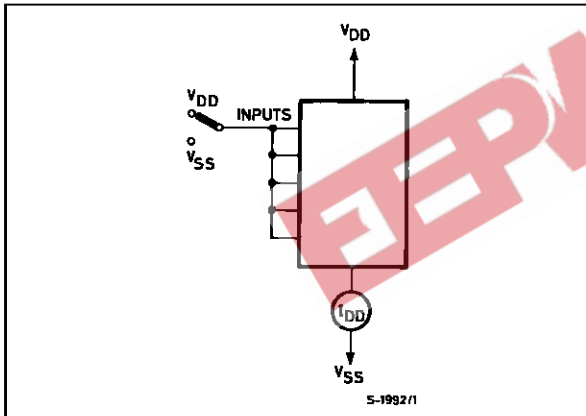

Input Voltage.

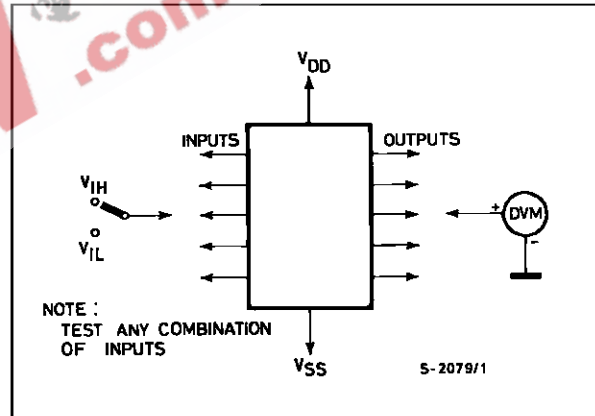

Input Leakage Current.

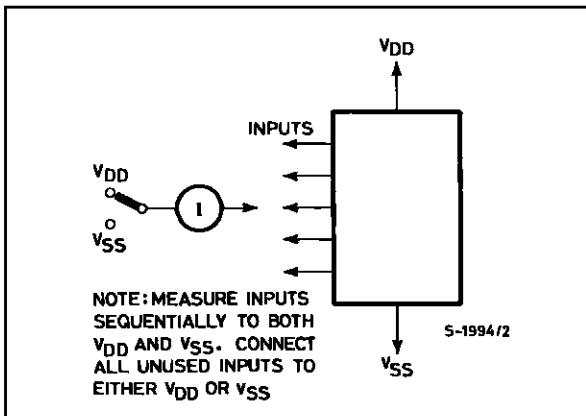

HCC/HCF4073B/4081B/4082B

Plastic DIP14 MECHANICAL DATA

DIM.	mm			inch		
	MIN.	TYP.	MAX.	MIN.	TYP.	MAX.
a1	0.51			0.020		
B	1.39		1.65	0.055		0.065
b		0.5			0.020	
b1		0.25			0.010	
D			20			0.787
E		8.5			0.335	
e		2.54			0.100	
e3		15.24			0.600	
F			7.1			0.280
I			5.1			0.201
L		3.3			0.130	
Z	1.27		2.54	0.050		0.100

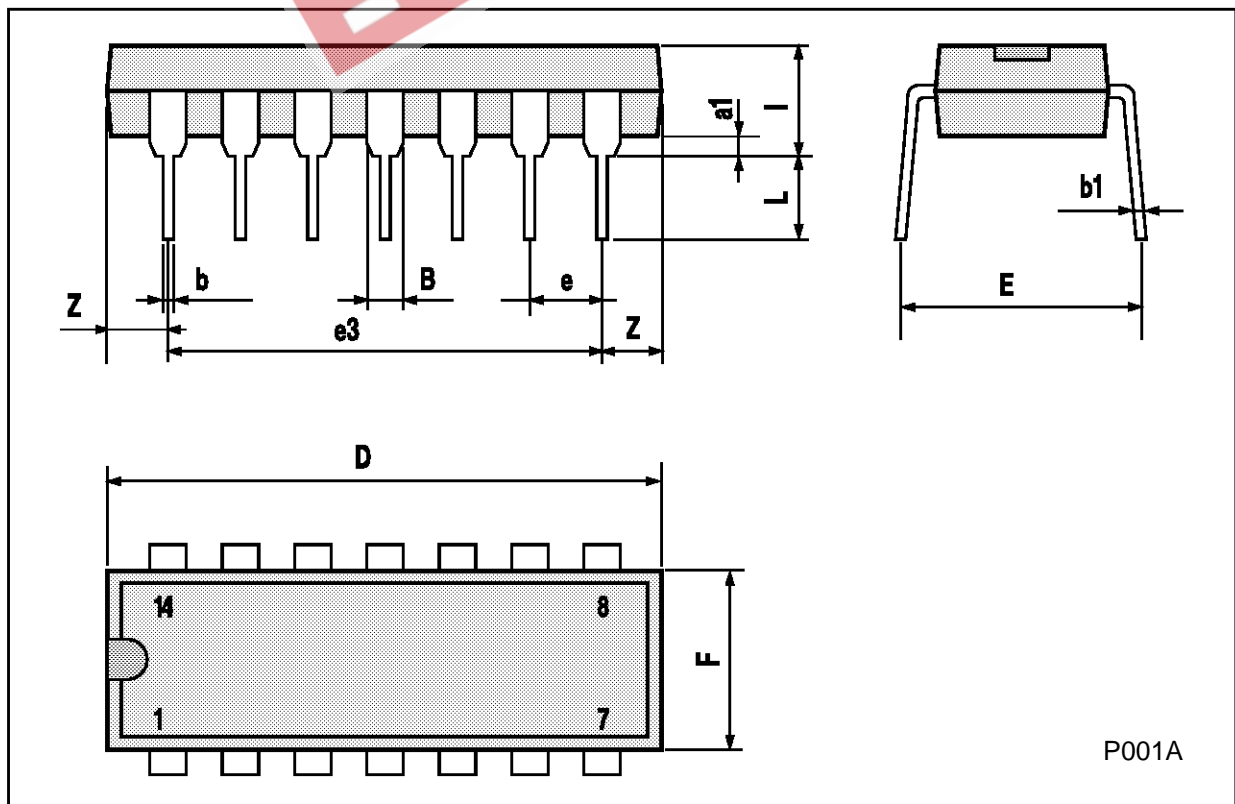

Ceramic DIP14/1 MECHANICAL DATA

DIM.	mm			inch		
	MIN.	TYP.	MAX.	MIN.	TYP.	MAX.
A			20			0.787
B			7.0			0.276
D		3.3			0.130	
E	0.38			0.015		
e3		15.24			0.600	
F	2.29		2.79	0.090		0.110
G	0.4		0.55	0.016		0.022
H	1.17		1.52	0.046		0.060
L	0.22		0.31	0.009		0.012
M	1.52		2.54	0.060		0.100
N			10.3			0.406
P	7.8		8.05	0.307		0.317
Q			5.08			0.200

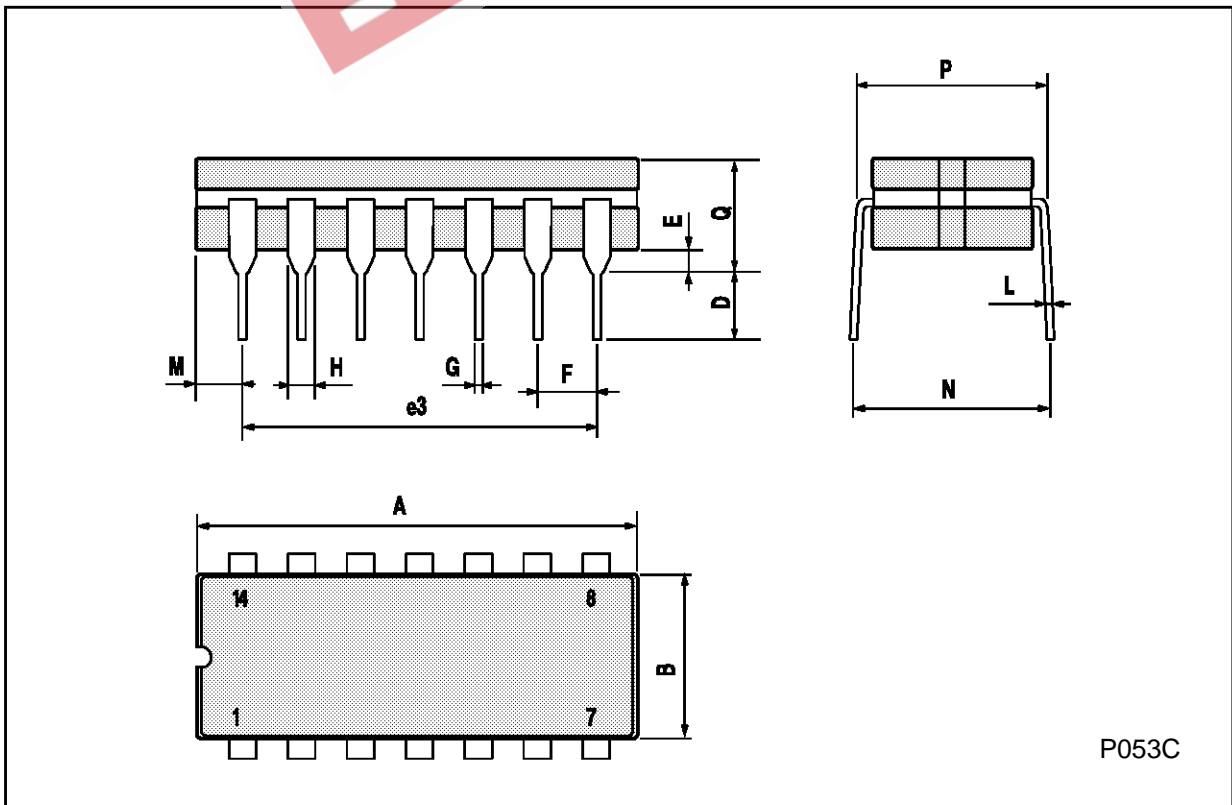

SO14 MECHANICAL DATA

DIM.	mm			inch		
	MIN.	TYP.	MAX.	MIN.	TYP.	MAX.
A			1.75			0.068
a1	0.1		0.2	0.003		0.007
a2			1.65			0.064
b	0.35		0.46	0.013		0.018
b1	0.19		0.25	0.007		0.010
C		0.5			0.019	
c1	45° (typ.)					
D	8.55		8.75	0.336		0.344
E	5.8		6.2	0.228		0.244
e		1.27			0.050	
e3		7.62			0.300	
F	3.8		4.0	0.149		0.157
G	4.6		5.3	0.181		0.208
L	0.5		1.27	0.019		0.050
M			0.68			0.026
S	8° (max.)					

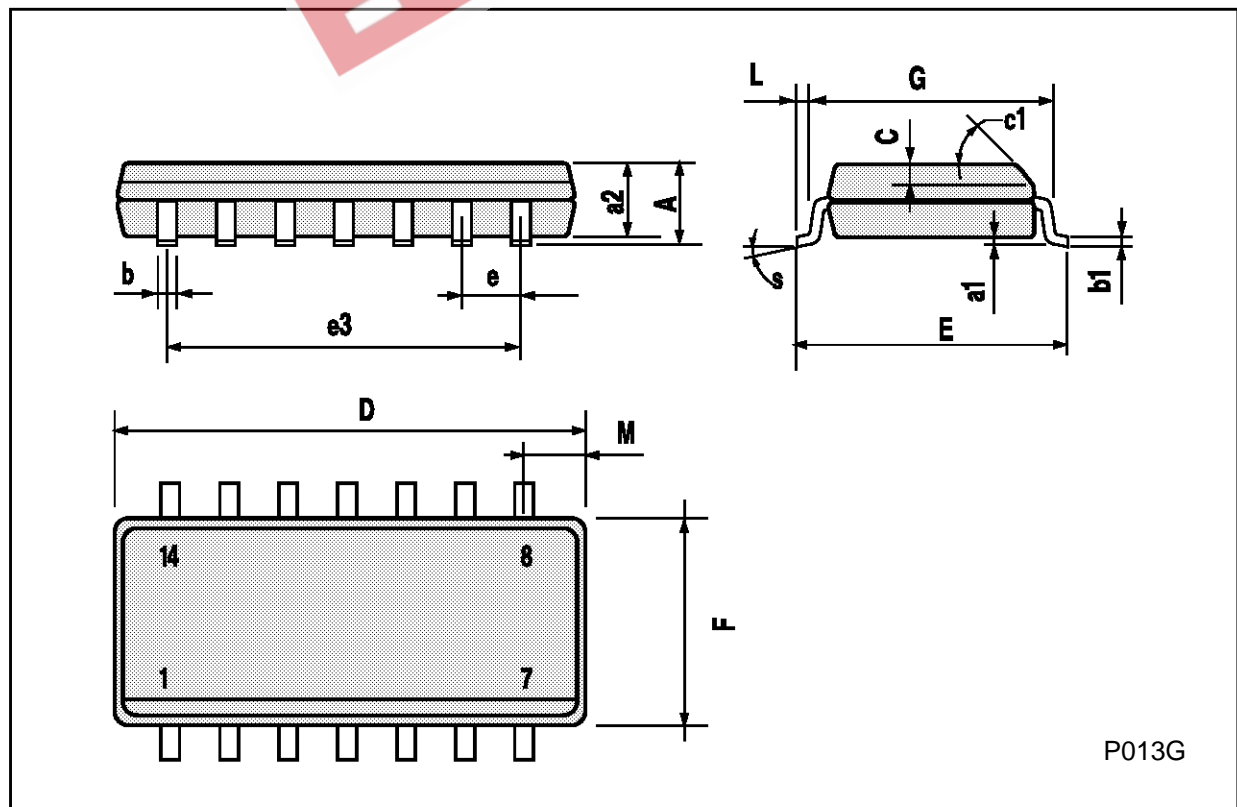

PLCC20 MECHANICAL DATA

DIM.	mm			inch		
	MIN.	TYP.	MAX.	MIN.	TYP.	MAX.
A	9.78		10.03	0.385		0.395
B	8.89		9.04	0.350		0.356
D	4.2		4.57	0.165		0.180
d1		2.54			0.100	
d2		0.56			0.022	
E	7.37		8.38	0.290		0.330
e		1.27			0.050	
e3		5.08			0.200	
F		0.38			0.015	
G			0.101			0.004
M		1.27			0.050	
M1		1.14			0.045	

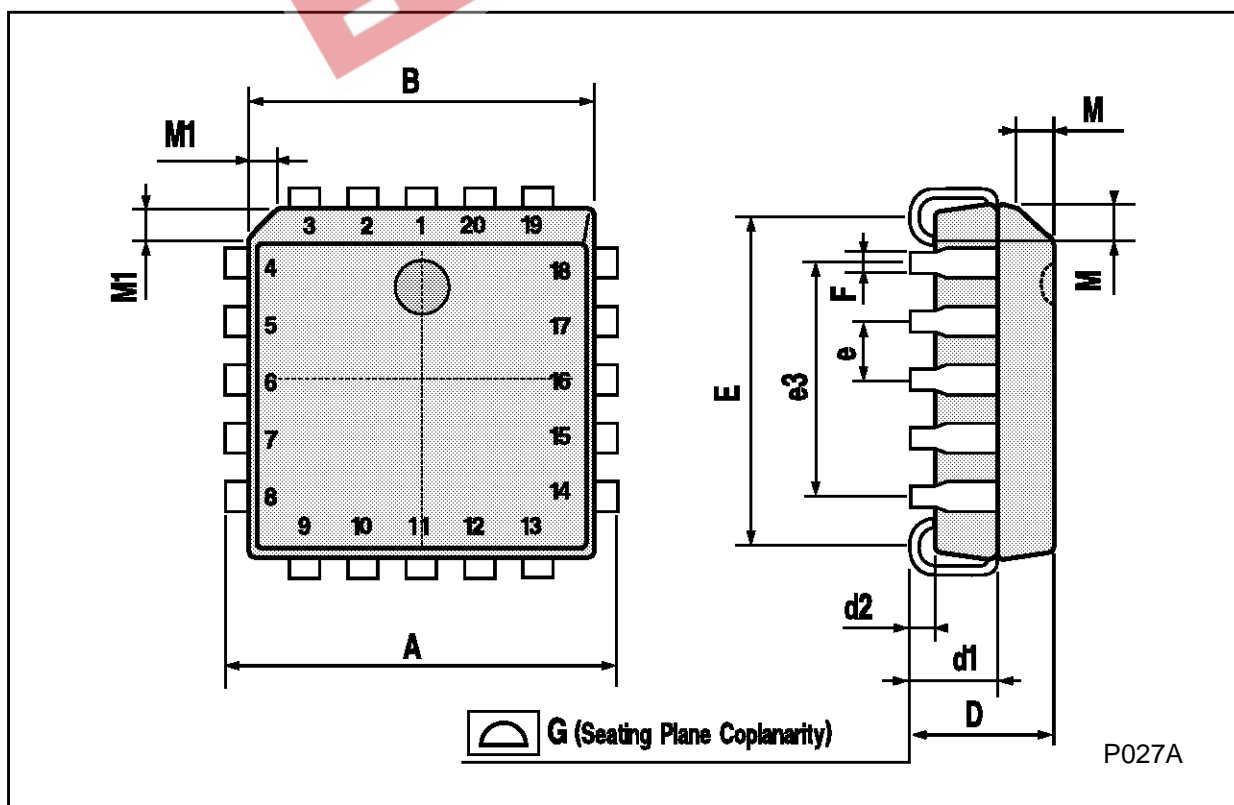

EEPW 电子產品世界
.com.cn

Information furnished is believed to be accurate and reliable. However, SGS-THOMSON Microelectronics assumes no responsibility for the consequences of use of such information nor for any infringement of patents or other rights of third parties which may result from its use. No license is granted by implication or otherwise under any patent or patent rights of SGS-THOMSON Microelectronics. Specifications mentioned in this publication are subject to change without notice. This publication supersedes and replaces all information previously supplied. SGS-THOMSON Microelectronics products are not authorized for use as critical components in life support devices or systems without express written approval of SGS-THOMSON Microelectronics.

© 1994 SGS-THOMSON Microelectronics - All Rights Reserved

SGS-THOMSON Microelectronics GROUP OF COMPANIES
Australia - Brazil - France - Germany - Hong Kong - Italy - Japan - Korea - Malaysia - Malta - Morocco - The Netherlands -
Singapore - Spain - Sweden - Switzerland - Taiwan - Thailand - United Kingdom - U.S.A