

## OR GATE

- 4071B - QUAD 2-INPUT OR GATE**
- 4072B - QUAD 4-INPUT OR GATE**
- 4075B - TRIPLE 3-INPUT OR GATE**

- MEDIUM-SPEED OPERATION  $t_{PLH}$ ,  $t_{PHL}$  = 60ns. (typ.) AT  $V_{DD} = 10V$
- QUIESCENT CURRENT SPECIFIED TO 20V FOR HCC DEVICE
- 5V, 10V AND 15V PARAMETRIC RATINGS
- INPUT CURRENT OF 100nA AT 18V AND 25°C FOR HCC DEVICE
- 100% TESTED FOR QUIESCENT CURRENT
- MEETS ALL REQUIREMENTS OF JEDEC TENTATIVE STANDARD N°. 13A, "STANDARD SPECIFICATIONS FOR DESCRIPTION OF "B" SERIES CMOS DEVICES"

### DESCRIPTION

The **HCC4071B/4072B** and **4075B** (extended temperature range) and **HCF4071B/4072B** and **4075B** (intermediate temperature range) are monolithic integrated circuits, available in 14-lead plastic or ceramic package and plastic micropackage.

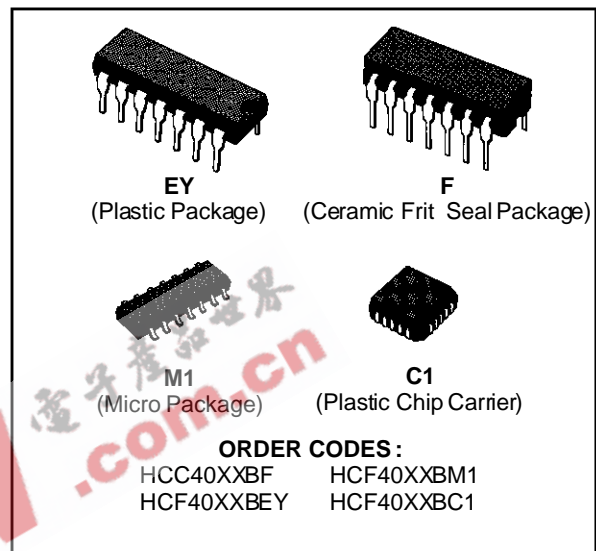

The **HCC/HCF4071B, 4072B** and **4075B** OR gates provide the system designer with direct implementation of the positive-logic OR function and supplement the existing family of COS/MOS gates.

### PIN CONNECTIONS

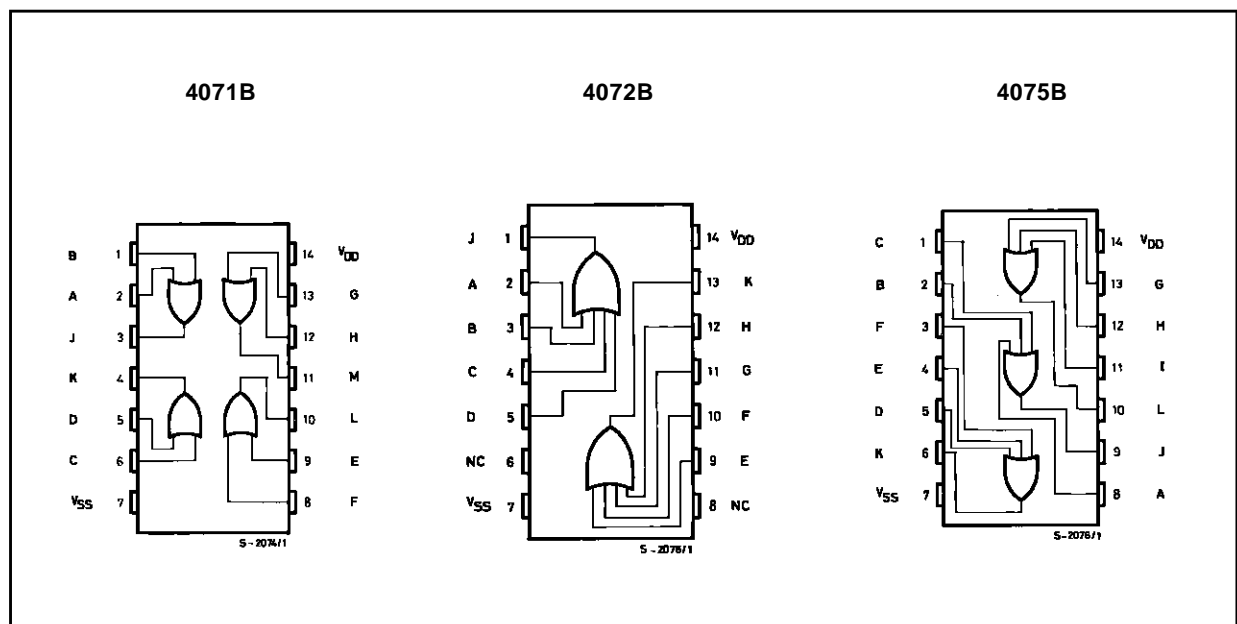

# HCC/HFC4071B/72B/75B

## ABSOLUTE MAXIMUM RATINGS

Symbol	Parameter	Value	Unit
V <sub>DD</sub> *	Supply Voltage : <b>HCC</b> Types	- 0.5 to + 20	V
	<b>HCF</b> Types	- 0.5 to + 18	V
V <sub>i</sub>	Input Voltage	- 0.5 to V <sub>DD</sub> + 0.5	V
I <sub>I</sub>	DC Input Current (any one input)	± 10	mA
P <sub>tot</sub>	Total Power Dissipation (per package)	200	mW
	Dissipation per Output Transistor for Top = Full Package-temperature Range	100	mW
T <sub>op</sub>	Operating Temperature : <b>HCC</b> Types	- 55 to + 125	°C
	<b>HCF</b> Types	- 40 to + 85	°C
T <sub>stg</sub>	Storage Temperature	- 65 to + 150	°C

Stresses above those listed under "Absolute Maximum Ratings" may cause permanent damage to the device. This is a stress rating only and functional operation of the device at these or any other conditions above those indicated in the operational sections of this specification is not implied. Exposure to absolute maximum rating conditions for external periods may affect device reliability.

\* All voltage values are referred to V<sub>SS</sub> pin voltage.

## RECOMMENDED OPERATING CONDITIONS

Symbol	Parameter	Value	Unit
V <sub>DD</sub>	Supply Voltage : <b>HCC</b> Types	3 to 18	V
	<b>HCF</b> Types	3 to 15	V
V <sub>I</sub>	Input Voltage	0 to V <sub>DD</sub>	V
T <sub>op</sub>	Operating Temperature : <b>HCC</b> Types	- 55 to + 125	°C
	<b>HCF</b> Types	- 40 to + 85	°C

Typical Voltage and Current Transfer Characteristics.

Typical Output Low (sink) Current Characteristics.

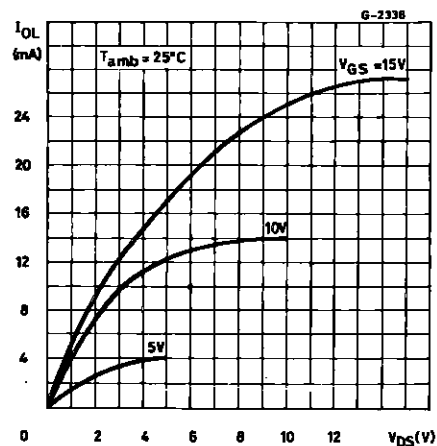
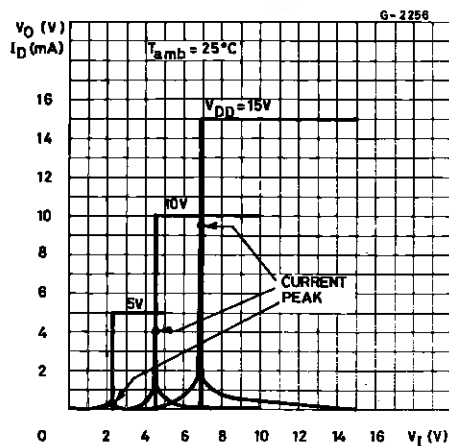

Minimum Output Low (sink) Current Characteristics.

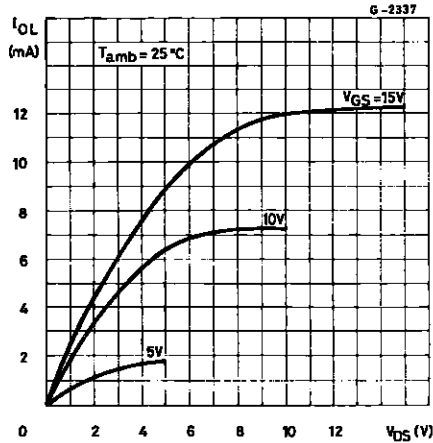

Typical Output High (source) Current Characteristics.

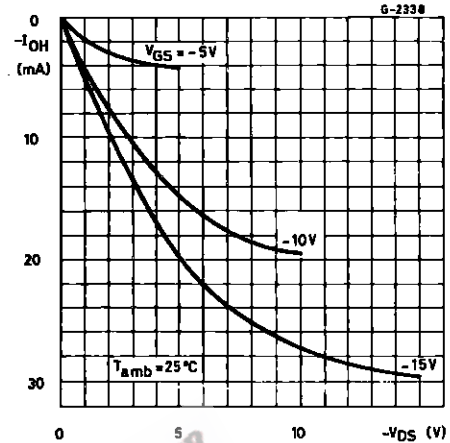

Minimum Output High (source) Current Characteristics.

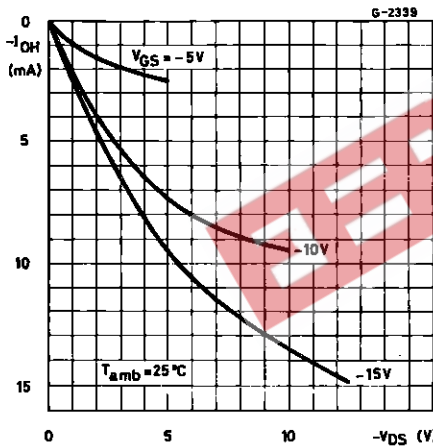

Typical Propagation Delay Time vs. Load Capacitance.

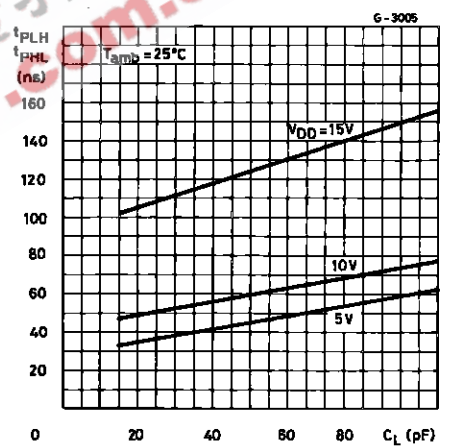

Typical Transition Time vs. Load Capacitance.

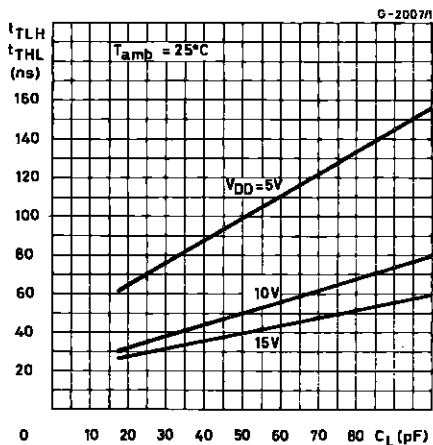

Typical Dynamic Power Dissipation vs. Frequency.

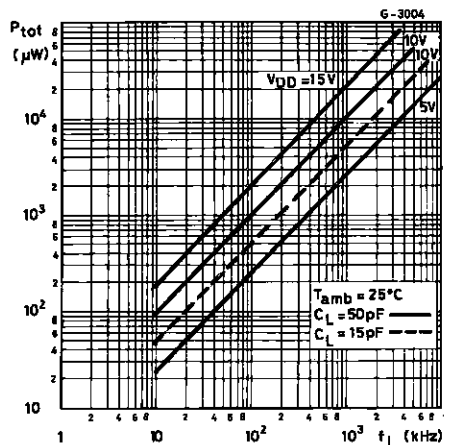

# HCC/HFC4071B/72B/75B

## SCHEMATIC DIAGRAMS

4071B – 1 of 4 identical OR gates

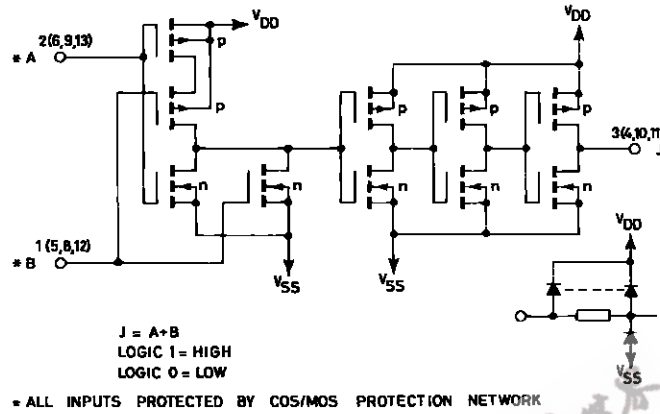

4072B – 1 of 2 identical OR gates

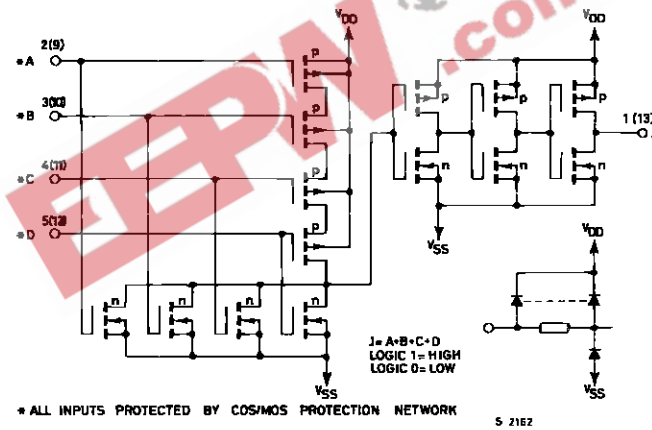

4075B – 1 of 3 identical OR gates

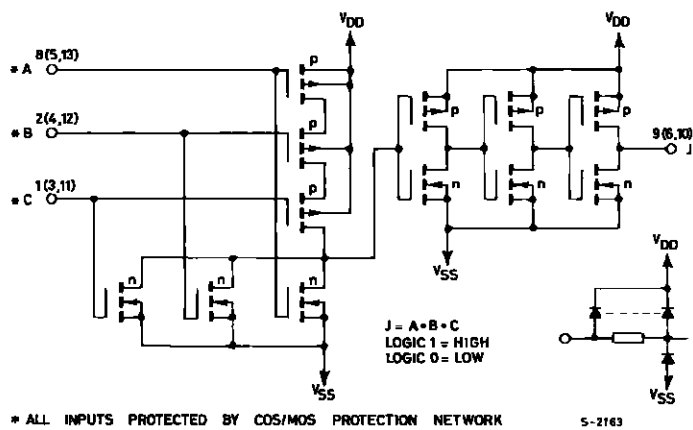

**STATIC ELECTRICAL CHARACTERISTICS** (over recommended operating conditions)

Symbol	Parameter		Test Conditions				Value						Unit	
			V <sub>I</sub> (V)	V <sub>O</sub> (V)	I <sub>O</sub>   (μA)	V <sub>DD</sub> (V)	T <sub>Low</sub> *		25°C			T <sub>High</sub> *		
							Min.	Max.	Min.	Typ.	Max.	Min.		Max.
I <sub>L</sub>	Quiescent Current	HCC Types	0/ 5			5		0.25		0.01	0.25		7.5	μA
			0/10			10		0.5		0.01	0.5		15	
			0/15			15		1		0.01	1		30	
			0/20			20		5		0.02	5		150	
		HCF Types	0/ 5			5		1		0.01	1		7.5	
			0/10			10		2		0.01	2		15	
V <sub>OH</sub>	Output High Voltage		0/ 5		< 1	5	4.95		4.95			4.95	V	
			0/10		< 1	10	9.95		9.95			9.95		
			0/15		< 1	15	14.95		14.95			14.95		
V <sub>OL</sub>	Output Low Voltage		5/0		< 1	5		0.05		0.05		0.05	V	
			10/0		< 1	10		0.05		0.05		0.05		
			15/0		< 1	15		0.05		0.05		0.05		
V <sub>IH</sub>	Input High Voltage			0.5/4.5	< 1	5	3.5		3.5			3.5	V	
				1/9	< 1	10	7		7			7		
				1.5/13.5	< 1	15	11		11			11		
V <sub>IL</sub>	Input Low Voltage			4.5/0.5	< 1	5		1.5		1.5		1.5	V	
				9/1	< 1	10		3		3		3		
				13.5/1.5	< 1	15		4		4		4		
I <sub>OH</sub>	Output Drive Current	HCC Types	0/ 5	2.5		5	- 2		- 1.6	- 3.2		- 1.15	mA	
			0/ 5	4.6		5	- 0.64		- 0.51	- 1		- 0.36		
			0/10	9.5		10	- 1.6		- 1.3	- 2.6		- 0.9		
			0/15	13.5		15	- 4.2		- 3.4	- 6.8		- 2.4		
		HCF Types	0/ 5	2.5		5	- 1.53		- 1.36	- 3.2		- 1.1		
			0/ 5	4.6		5	- 0.52		- 0.44	- 1		- 0.36		
			0/10	9.5		10	- 1.3		- 1.1	- 2.6		- 0.9		
			0/15	13.5		15	- 3.6		- 3.0	- 6.8		- 2.4		
I <sub>OL</sub>	Output Sink Current	HCC Types	0/ 5	0.4		5	0.64		0.51	1		0.36	mA	
			0/10	0.5		10	1.6		1.3	2.6		0.9		
			0/15	1.5		15	4.2		3.4	6.8		2.4		
		HCF Types	0/ 5	0.4		5	0.52		0.44	1		0.36		
			0/10	0.5		10	1.3		1.1	2.6		0.9		
			0/15	1.5		15	3.6		3.0	6.8		2.4		
I <sub>IH</sub> , I <sub>IL</sub>	Input Leakage Current	HCC Types	0/18	Any Input		18		± 0.1		±10 <sup>-5</sup>	± 0.1		± 1	
		HCF Types	0/15			15		± 0.3		±10 <sup>-5</sup>	± 0.3		± 1	
C <sub>i</sub>	Input Capacitance			Any Input					5	7.5			pF	

\* T<sub>Low</sub> = - 55°C for **HCC** device : - 40°C for **HCF** device.  
 \* T<sub>High</sub> = + 125°C for **HCC** device : + 85°C for **HCF** device.  
 The Noise Margin for both "1" and "0" level is : 1V min. with V<sub>DD</sub> = 5V, 2V min. with V<sub>DD</sub> = 10V, 2.5 V min. with V<sub>DD</sub> = 15V.

## HCC/HFC4071B/72B/75B

**DYNAMIC ELECTRICAL CHARACTERISTICS** ( $T_{amb} = 25^{\circ}\text{C}$ ,  $C_L = 50\text{pF}$ ,  $R_L = 200\text{k}\Omega$ , typical temperature coefficient for all  $V_{DD} = 0.3\%/^{\circ}\text{C}$  values, all input rise and fall time = 20ns)

Symbol	Parameter	Test Conditions		Value			Unit
			$V_{DD}$ (V)	Min.	Typ.	Max.	
$t_{PHL}$	Propagation Delay Time		5		125	250	ns
			10		60	120	
			15		45	90	
$t_{PLH}$	Propagation Delay Time		5		175	350	ns
			70		50	140	
			15		50	140	
$t_{THL}, t_{TLH}$	Transition Time		5		100	200	ns
			10		50	100	
			15		40	80	

### TEST CIRCUITS

Quiescent Device Current.

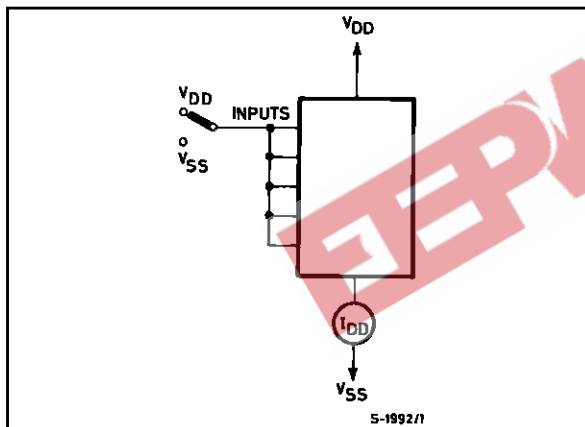

Input Voltage.

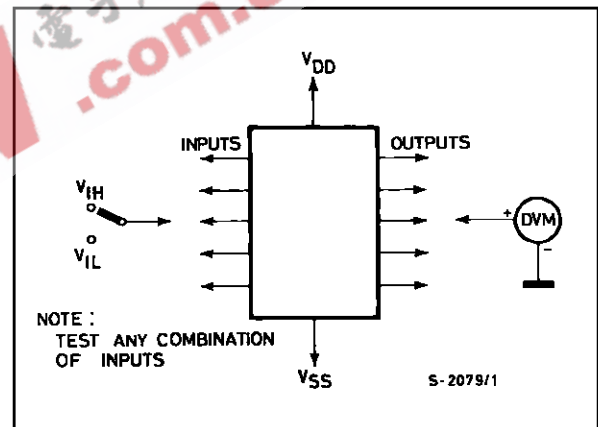

Input Leakage Current.

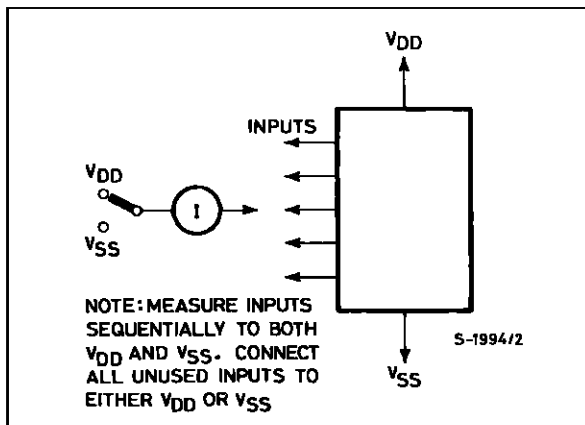

**Plastic DIP14 MECHANICAL DATA**

DIM.	mm			inch		
	MIN.	TYP.	MAX.	MIN.	TYP.	MAX.
a1	0.51			0.020		
B	1.39		1.65	0.055		0.065
b		0.5			0.020	
b1		0.25			0.010	
D			20			0.787
E		8.5			0.335	
e		2.54			0.100	
e3		15.24			0.600	
F			7.1			0.280
I			5.1			0.201
L		3.3			0.130	
Z	1.27		2.54	0.050		0.100

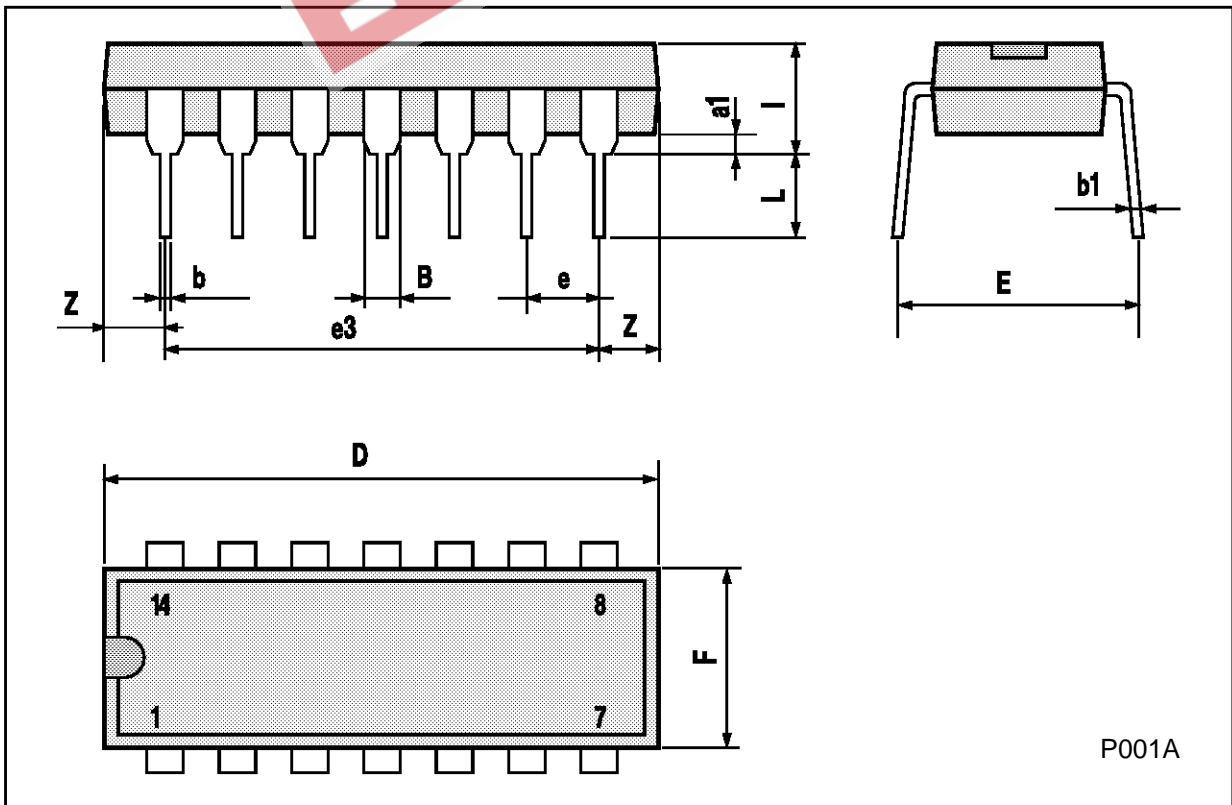

HCC/HFC4071B/72B/75B

**Ceramic DIP14/1 MECHANICAL DATA**

DIM.	mm			inch		
	MIN.	TYP.	MAX.	MIN.	TYP.	MAX.
A			20			0.787
B			7.0			0.276
D		3.3			0.130	
E	0.38			0.015		
e3		15.24			0.600	
F	2.29		2.79	0.090		0.110
G	0.4		0.55	0.016		0.022
H	1.17		1.52	0.046		0.060
L	0.22		0.31	0.009		0.012
M	1.52		2.54	0.060		0.100
N			10.3			0.406
P	7.8		8.05	0.307		0.317
Q			5.08			0.200

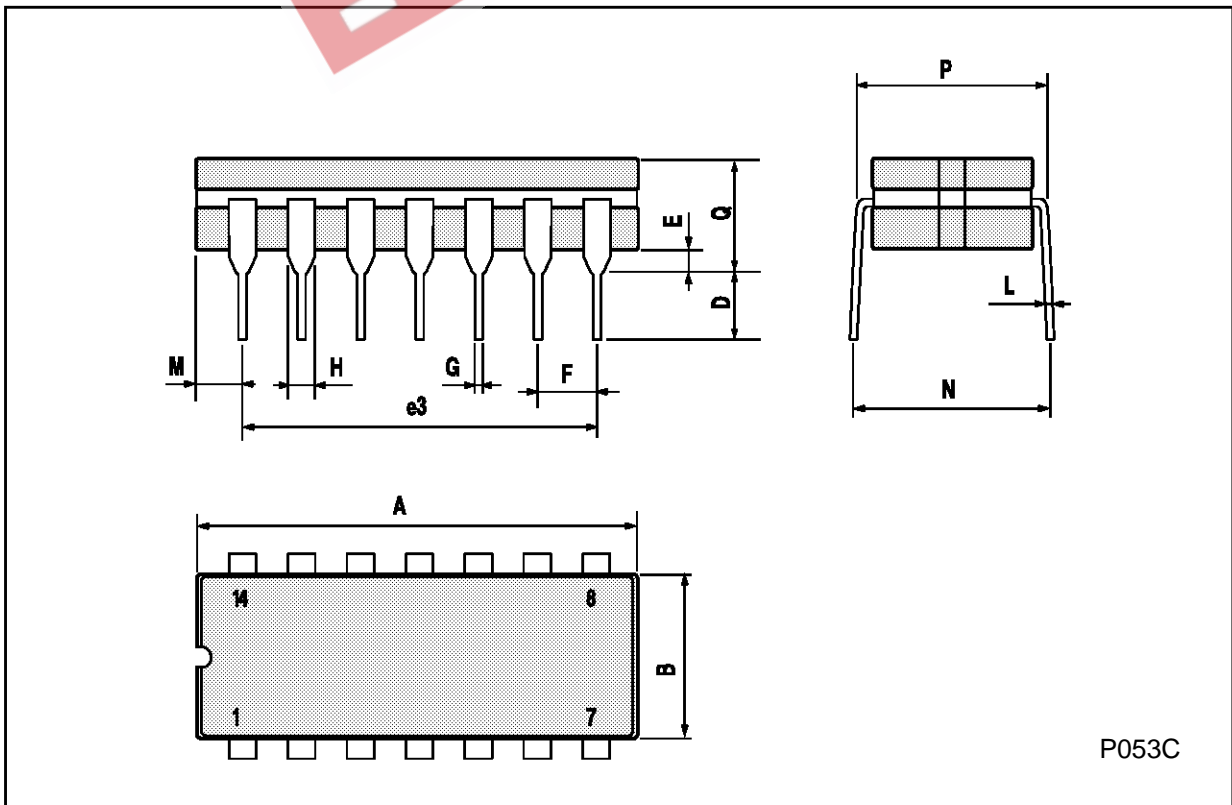



**SO14 MECHANICAL DATA**

DIM.	mm			inch		
	MIN.	TYP.	MAX.	MIN.	TYP.	MAX.
A			1.75			0.068
a1	0.1		0.2	0.003		0.007
a2			1.65			0.064
b	0.35		0.46	0.013		0.018
b1	0.19		0.25	0.007		0.010
C		0.5			0.019	
c1	45° (typ.)					
D	8.55		8.75	0.336		0.344
E	5.8		6.2	0.228		0.244
e		1.27			0.050	
e3		7.62			0.300	
F	3.8		4.0	0.149		0.157
G	4.6		5.3	0.181		0.208
L	0.5		1.27	0.019		0.050
M			0.68			0.026
S	8° (max.)					

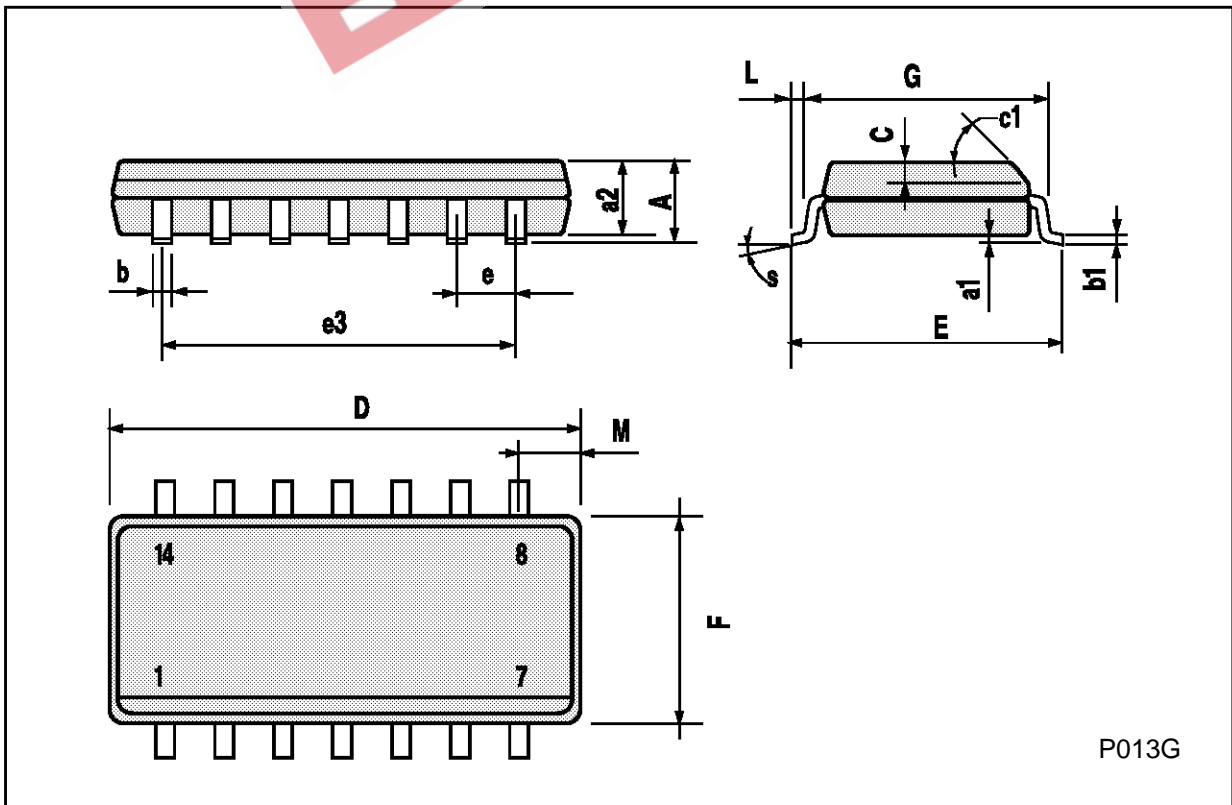

P013G

**PLCC20 MECHANICAL DATA**

DIM.	mm			inch		
	MIN.	TYP.	MAX.	MIN.	TYP.	MAX.
A	9.78		10.03	0.385		0.395
B	8.89		9.04	0.350		0.356
D	4.2		4.57	0.165		0.180
d1		2.54			0.100	
d2		0.56			0.022	
E	7.37		8.38	0.290		0.330
e		1.27			0.050	
e3		5.08			0.200	
F		0.38			0.015	
G			0.101			0.004
M		1.27			0.050	
M1		1.14			0.045	

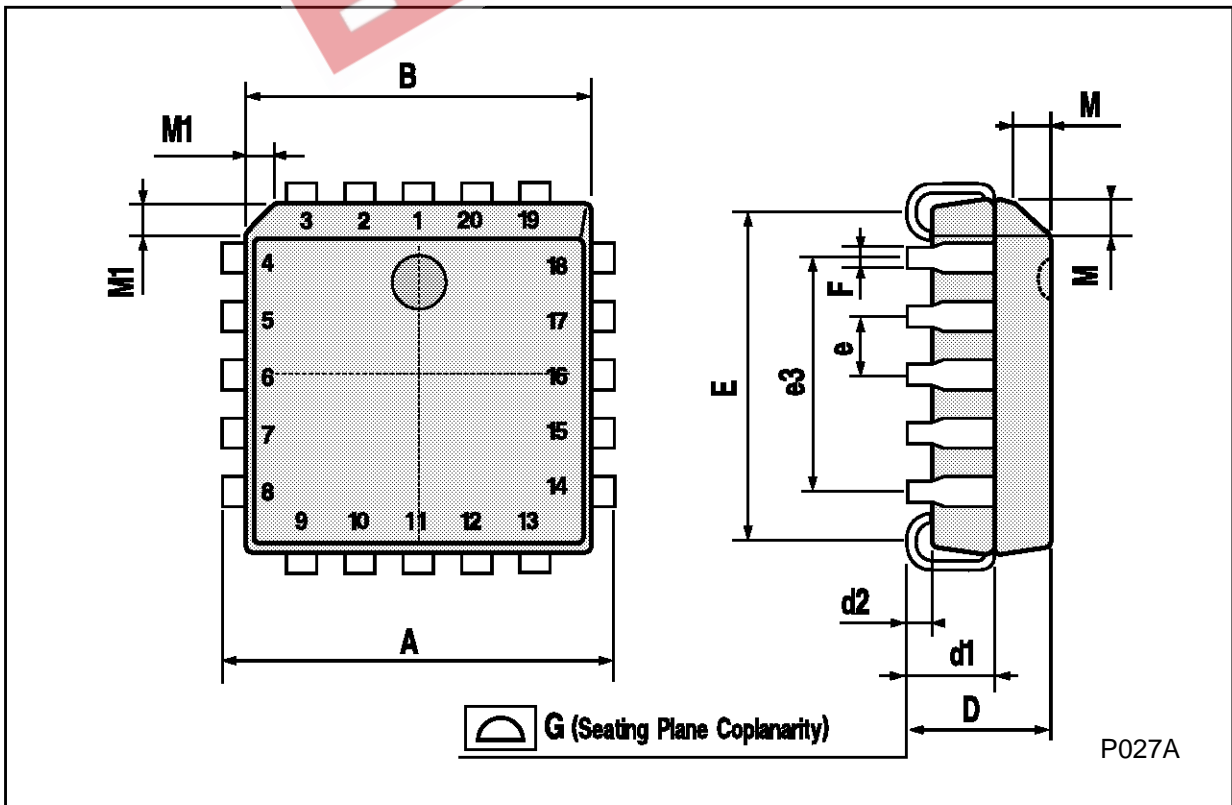

EEPW 电子產品世界  
.com.cn

Information furnished is believed to be accurate and reliable. However, SGS-THOMSON Microelectronics assumes no responsibility for the consequences of use of such information nor for any infringement of patents or other rights of third parties which may result from its use. No license is granted by implication or otherwise under any patent or patent rights of SGS-THOMSON Microelectronics. Specifications mentioned in this publication are subject to change without notice. This publication supersedes and replaces all information previously supplied. SGS-THOMSON Microelectronics products are not authorized for use as critical components in life support devices or systems without express written approval of SGS-THOMSON Microelectronics.

© 1994 SGS-THOMSON Microelectronics - All Rights Reserved

SGS-THOMSON Microelectronics GROUP OF COMPANIES  
Australia - Brazil - France - Germany - Hong Kong - Italy - Japan - Korea - Malaysia - Malta - Morocco - The Netherlands -  
Singapore - Spain - Sweden - Switzerland - Taiwan - Thailand - United Kingdom - U.S.A