

BINARY RATE MULTIPLIER

- CASCADABLE IN MULTIPLES OF 4-BITS
- SET TO "15" INPUT AND "15" DETECT OUTPUT
- QUIESCENT CURRENT SPECIFIED TO 20V FOR HCC DEVICE
- STANDARDIZED SYMMETRICAL OUTPUT CHARACTERISTICS
- INPUT CURRENT OF 100nA AT 18V AND 25°C FOR HCC DEVICE
- 100% TESTED FOR QUIESCENT CURRENT
- MEETS ALL REQUIREMENTS OF JEDEC TENTATIVE STANDARD N°. 13A, "STANDARD SPECIFICATIONS FOR DESCRIPTION OF "B" SERIES CMOS DEVICES"

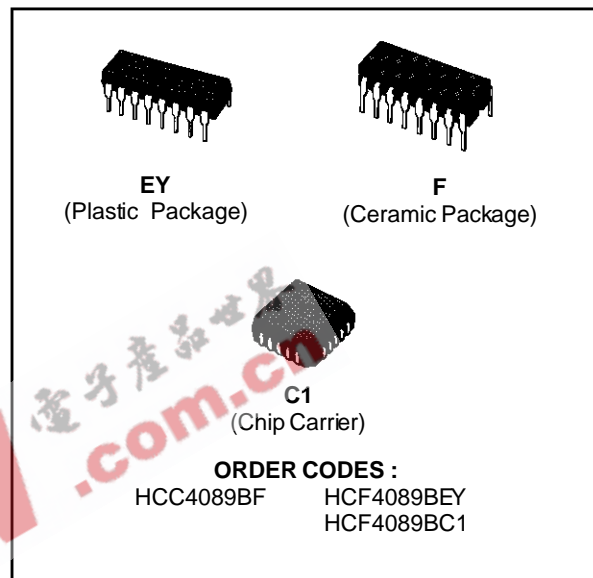

DESCRIPTION

The **HCC4089B** (extended temperature range) and **HCF4089B** (intermediate temperature range) are monolithic integrated circuit available in 16-lead dual in-line plastic or ceramic package.

The **HCC/HCF4089B** is a low-power 4-bit digital rate multiplier that provides an output pulse rate that is the clock-input-pulse rate multiplied by 1/16 times the binary input. For example, when the binary input number is 13, there will be 13 output pulses for every 16 input pulses.

The **HCC/HCF4089B** has an internal synchronous 4-bit counter which, together with one of the four binary input bits, produces pulse trains as shown in timing diagram.

If more than one binary input bit is high, the resulting pulse train is a combination of the above separate pulse trains. This device may be used to perform arithmetic operations (add, subtract, divide, raise to a power), solve algebraic and differential equations, generate natural logarithms and trigonometric functions, A/D and D/A conversions, and frequency division.

PIN CONNECTIONS

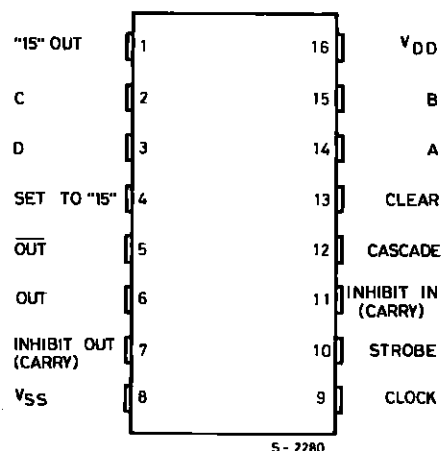

HCC/HCF4089B

FUNCTIONAL DIAGRAM

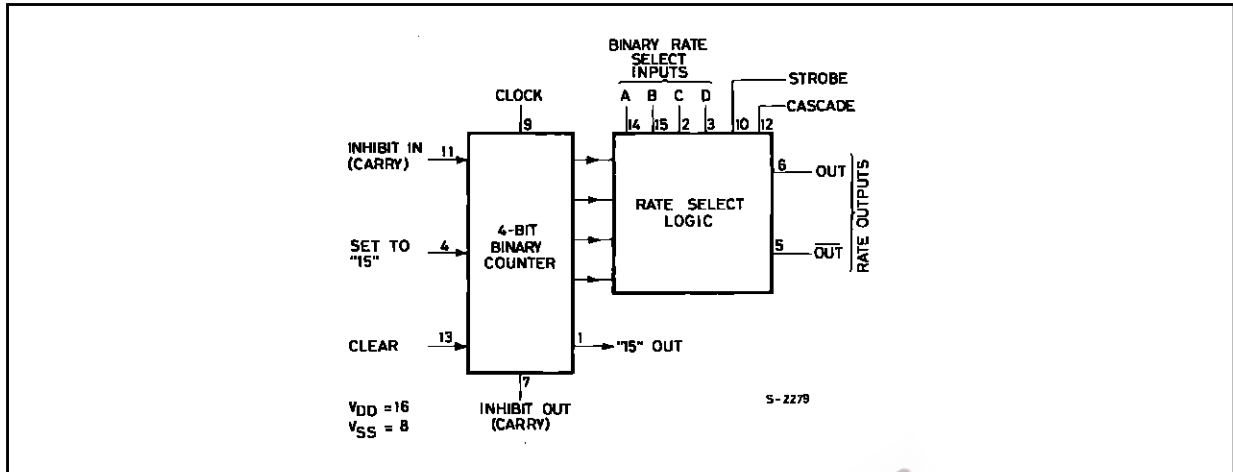

ABSOLUTE MAXIMUM RATINGS

Symbol	Parameter	Value	Unit
V_{DD}^*	Supply Voltage : HCC Types HCF Types	- 0.5 to + 20 - 0.5 to + 18	V V
V_i	Input Voltage	- 0.5 to $V_{DD} + 0.5$	V
I_i	DC Input Current (any one input)	± 10	mA
P_{tot}	Total Power Dissipation (per package) Dissipation per Output Transistor for T_{op} = Full Package-temperature Range	200 100	mW mW
T_{op}	Operating Temperature : HCC Types HCF Types	- 55 to + 125 - 40 to + 85	$^{\circ}C$ $^{\circ}C$
T_{stg}	Storage Temperature	- 65 to + 150	$^{\circ}C$

Stresses above those listed under "Absolute Maximum Ratings" may cause permanent damage to the device. This is a stress rating only and functional operation of the device at these or any other conditions above those indicated in the operational sections of this specification is not implied. Exposure to absolute maximum rating conditions for external periods may affect device reliability.

* All voltage values are referred to V_{SS} pin voltage.

RECOMMENDED OPERATING CONDITIONS

Symbol	Parameter	Value	Unit
V_{DD}	Supply Voltage : HCC Types HCF Types	3 to 18 3 to 15	V V
V_i	Input Voltage	0 to V_{DD}	V
T_{op}	Operating Temperature : HCC Types HCF Types	- 55 to + 125 - 40 to + 85	$^{\circ}C$ $^{\circ}C$

LOGIC DIAGRAM

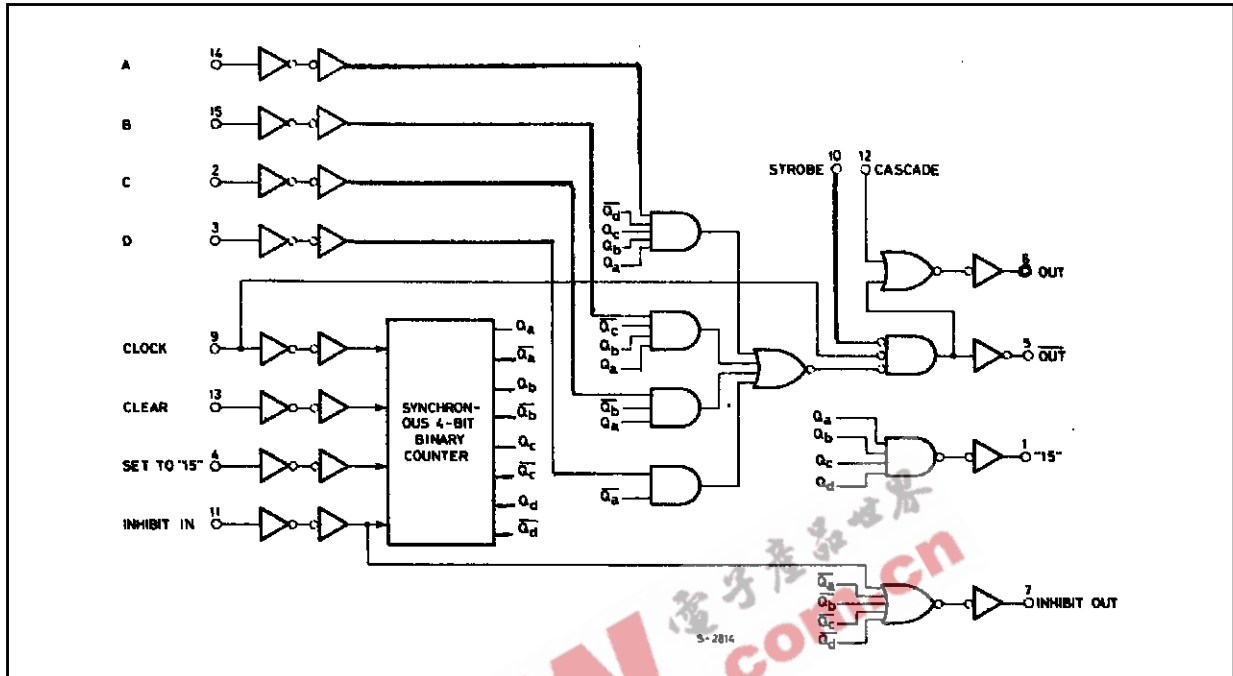

TRUTH TABLE

Inputs										Outputs			
Number of Pulses or Input Logic Level (0 = low ; 1 = high ; X = don't care)										Number of Pulses or Output Logic Level (L = low ; H = high)			
D	C	B	A	CLK	INH IN	STR	CAS	CLR	SET	OUT	$\overline{\text{OUT}}$	INH OUT	"15" OUT
0	0	0	0	16	0	0	0	0	0	L	H	1	1
0	0	0	1	16	0	0	0	0	0	1	1	1	1
0	0	1	0	16	0	0	0	0	0	2	2	1	1
0	0	1	1	16	0	0	0	0	0	3	3	1	1
0	1	0	0	16	0	0	0	0	0	4	4	1	1
0	1	0	1	16	0	0	0	0	0	5	5	1	1
0	1	1	0	16	0	0	0	0	0	6	6	1	1
0	1	1	1	16	0	0	0	0	0	7	7	1	1
1	0	0	0	16	0	0	0	0	0	8	8	1	1
1	0	0	1	16	0	0	0	0	0	9	9	1	1
1	0	1	0	16	0	0	0	0	0	10	10	1	1
1	0	1	1	16	0	0	0	0	0	11	11	1	1
1	1	0	0	16	0	0	0	0	0	12	12	1	1
1	1	0	1	16	0	0	0	0	0	13	13	1	1
1	1	1	0	16	0	0	0	0	0	14	14	1	1
1	1	1	1	16	0	0	0	0	0	15	15	1	1
X	X	X	X	16	1	0	0	0	0	•	•	H	•
X	X	X	X	16	0	1	0	0	0	L	H	1	1
X	X	X	X	16	0	0	1	0	0	H	*	1	1
1	X	X	X	16	0	0	0	1	0	16	16	H	L
0	X	X	X	16	0	0	0	1	0	L	H	H	L
X	X	X	X	16	0	0	0	0	1	L	H	L	H

* Output same as the first 16 lines of this truth table (depending on values of A, B, C, D).

• Depends on internal state of counter.

HCC/HCF4089B

TIMING DIAGRAM

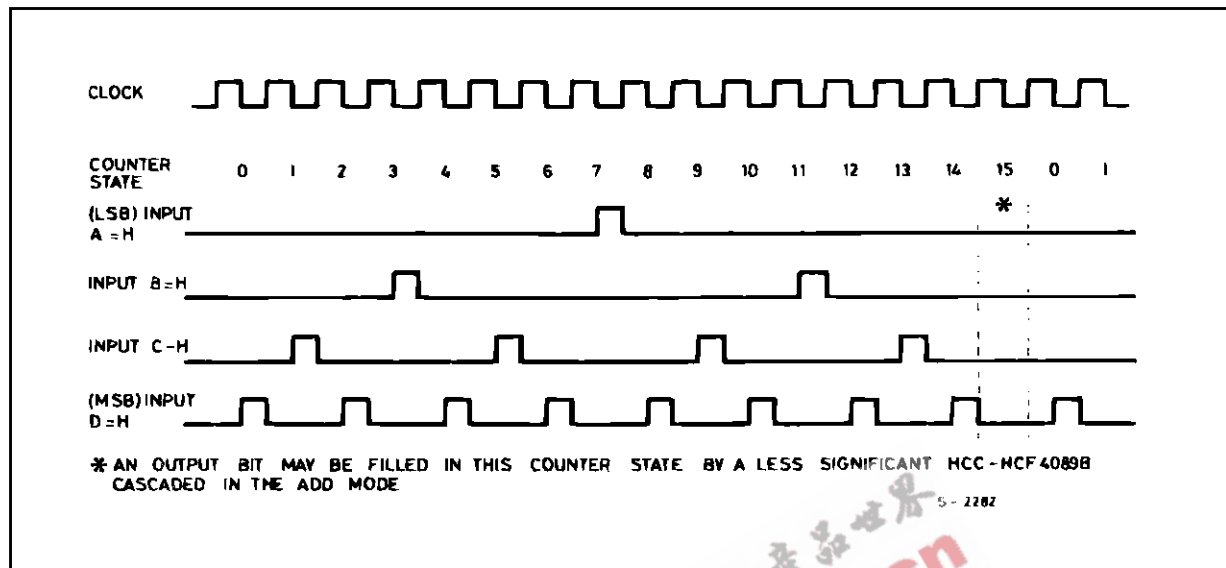

STATIC ELECTRICAL CHARACTERISTICS (over recommended operating conditions)

Symbol	Parameter	Test Conditions				Value						Unit			
		V _I (V)	V _O (V)	I _O (μA)	V _{DD} (V)	T _{Low} *		25°C			T _{High} *				
						Min.	Max.	Min.	Typ.	Max.	Min.		Max.		
I _L	Quiescent Current	HCC Types	0/5			5		5		0.04	5		150	μA	
			0/10			10		10		0.04	10		300		
			0/15			15		20		0.04	20		600		
			0/20			20		100		0.08	100		3000		
			HCF Types	0/5			5		20		0.04	20			150
				0/10			10		40		0.04	40			300
0/15				15		80		0.04	80		600				
V _{OH}	Output High Voltage	0/5		< 1	5	4.95		4.95			4.95		V		
		0/10		< 1	10	9.95		9.95			9.95				
		0/15		< 1	15	14.95		14.95			14.95				
V _{OL}	Output Low Voltage	5/0		< 1	5		0.05			0.05		0.05	V		
		10/0		< 1	10		0.05			0.05		0.05			
		15/0		< 1	15		0.05			0.05		0.05			
V _{IH}	Input High Voltage		0.5/4.5	< 1	5	3.5		3.5			3.5		V		
			1/9	< 1	10	7		7			7				
			1.5/13.5	< 1	15	11		11			11				
V _{IL}	Input Low Voltage		4.5/0.5	< 1	5		1.5			1.5		1.5	V		
			9/1	< 1	10		3			3		3			
			13.5/1.5	< 1	15		4			4					

* T_{Low} = -55°C for HCC device; -40°C for HCF device.

* T_{High} = +125°C for HCC device; +85°C for HCF device.

The Noise Margin for both "1" and "0" level is: 1V min. with V_{DD} = 5V, 2V min. with V_{DD} = 10V, 2.5V min. with V_{DD} = 15V.

STATIC ELECTRICAL CHARACTERISTICS (continued)

Symbol	Parameter	Test Conditions				Value						Unit	
		V _I (V)	V _O (V)	I _O (μ A)	V _{DD} (V)	T _{Low} *		25°C			T _{High} *		
						Min.	Max.	Min.	Typ.	Max.	Min.		Max.
I _{OH}	Output Drive Current	HCC Types	0/ 5	2.5		5	- 2		- 1.6	- 3.2		- 1.15	mA
			0/ 5	4.6		5	- 0.64		- 0.51	- 1		- 0.36	
			0/10	9.5		10	- 1.6		- 1.3	- 2.6		- 0.9	
			0/15	13.5		15	- 4.2		- 3.4	- 6.8		- 2.4	
		HCF Types	0/ 5	2.5		5	- 1.53		- 1.36	- 3.2		- 1.1	
			0/ 5	4.6		5	- 0.52		- 0.44	- 1		- 0.36	
			0/10	9.5		10	- 1.3		- 1.1	- 2.6		- 0.9	
			0/15	13.5		15	- 3.6		- 3.0	- 6.8		- 2.4	
I _{OL}	Output Sink Current	HCC Types	0/ 5	0.4		5	0.64		0.51	1		0.36	mA
			0/10	0.5		10	1.6		1.3	2.6		0.9	
			0/15	1.5		15	4.2		3.4	6.8		2.4	
		HCF Types	0/ 5	0.4		5	0.52		0.44	1		0.36	
			0/10	0.5		10	1.3		1.1	2.6		0.9	
			0/15	1.5		15	3.6		3.0	6.8		2.4	
I _{IH} , I _{IL}	Input Leakage Current	HCC Types	0/18	Any Input								± 1	
		HCF Types	0/15										18
C _I	Input Capacitance		Any Input						5	7.5		pF	

* T_{Low} = -55°C for HCC device; -40°C for HCF device.* T_{High} = +125°C for HCC device; +85°C for HCF device.The Noise Margin for both "1" and "0" level is: 1V min. with V_{DD} = 5V, 2V min. with V_{DD} = 10V, 2.5V min. with V_{DD} = 15V.

HCC/HCF4089B

DYNAMIC ELECTRICAL CHARACTERISTICS ($T_{amb} = 25^{\circ}\text{C}$, $C_L = 50\text{pF}$, $R_L = 200\text{k}\Omega$, typical temperature coefficient for all V_{DD} values is $0.3\%/^{\circ}\text{C}$, all input rise and fall times = 20ns)

Symbol	Parameter		Test Conditions		Value			Unit
				V_{DD} (V)	Min.	Typ.	Max.	
t_{PHL} , t_{PLH}	Propagation Delay Time	Clock to $\overline{\text{out}}$		5		110	220	ns
				10		55	110	
				15		45	90	
		Clock or Strobe to out		5		150	300	ns
				10		75	150	
				15		60	120	
		Clock to Inhibit High Level to Low Level		5		360	720	ns
				10		160	320	
				15		110	220	
		Low Level to High Level		5		250	500	ns
				10		100	200	
				15		75	150	
		Clear to out		5		380	760	ns
				10		175	350	
				15		130	260	
		Clock to "9" or "15" out		5		300	600	ns
				10		125	250	
				15		90	180	
		Cascade to out		5		90	180	ns
				10		45	90	
				15		35	70	
		Inhibit in to Inhibit out		5		160	320	ns
				10		75	150	
				15		55	110	
Set to out		5		330	660	ns		
		10		150	300			
		15		110	220			

DYNAMIC ELECTRICAL CHARACTERISTICS (continued)

Symbol	Parameter	Test Conditions		Value			Unit
			V _{DD} (V)	Min.	Typ.	Max.	
t _{THL} , t _{TLH}	Transition Time		5		100	200	ns
			10		50	100	
			15		40	80	
f _{CL}	Maximum Clock Frequency		5	1.2	2.4		MHz
			10	2.5	5		
			15	3.5	7		
t _w	Clock Pulse Width		5	330	165		ns
			10	170	85		
			15	100	50		
t _r , t _f	Clock Rise or Fall Time		5			15	μs
			10			15	
			15			15	
t _w	Set or Clear Pulse Width		5	160	80		ns
			10	90	45		
			15	60	30		
t _{setup}	Inhibit Input Setup Time, High Level to Low Level		5	100	50		ns
			10	40	20		
			15	20	10		
t _R	Inhibit, Input Removal Time		5	240	120		ns
			10	130	65		
			15	110	55		
t _R	Minimum Set Removal Time		5	150	75		ns
			10	80	40		
			15	50	25		
t _R	Clear Removal Time		5	60	30		ns
			10	40	20		
			15	30	15		

HCC/HCF4089B

APPLICATION NOTES

For words of more than 4 bits, **HCC/HCF4089B** devices may be cascaded in two different modes : an Add mode and a Multiply mode.

Two **HCC/HCF4089B**'s cascaded in the "Add" mode with a preset number of 189.

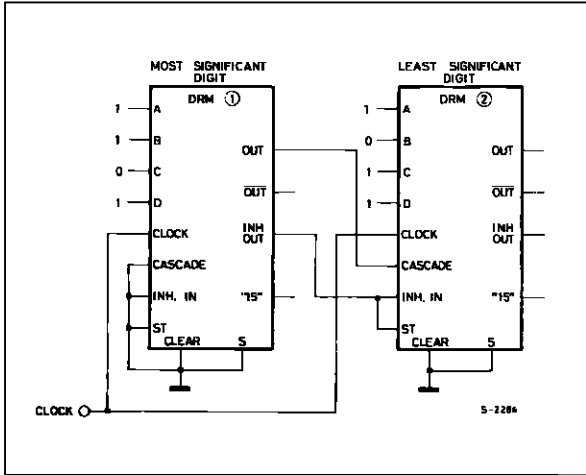

Nota :

In the Add mode some of the gaps left by the more significant unit at the count of 15 are filled in by the less significant units. For example, when two units are cascaded in the Add mode and programmed to 11 and 13, respectively, the more significant unit will have 11 output pulses for every 16 input pulses and the other unit will have 13 output pulses for every 256 input pulses for a total of

$$\frac{11}{16} + \frac{13}{256} = \frac{189}{256}$$

Two **HCC/HCF4089B**'s cascaded in the Multiply mode for Multiplication of two variables A and B with loop circuit control.

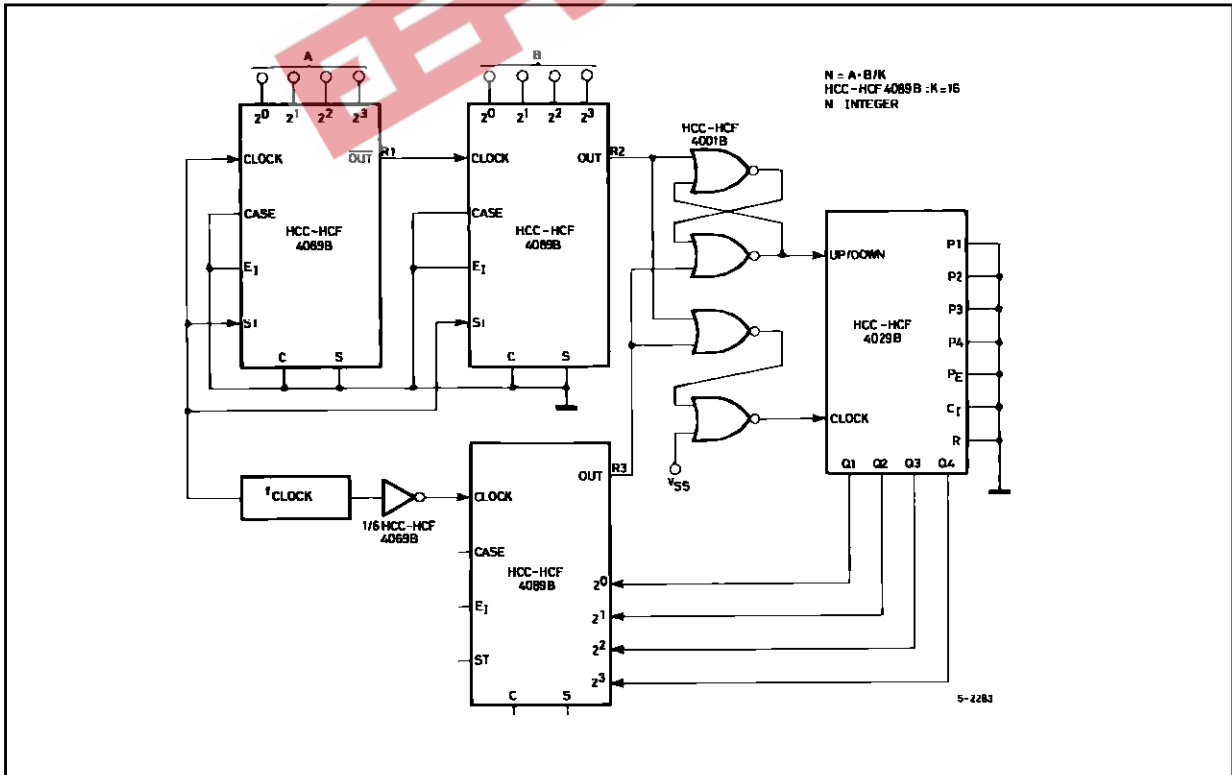

When the loop stabilises rate $R2 = \text{rate } R3$, thus $f_{\text{clock}} \left(\frac{A}{16} \cdot \frac{B}{16} \right) = f_{\text{clock}} \left(\frac{1}{16} \cdot \frac{N}{16} \right)$ therefore $N = A \cdot B$.

TEST CIRCUITS

Quiescent Device Current.

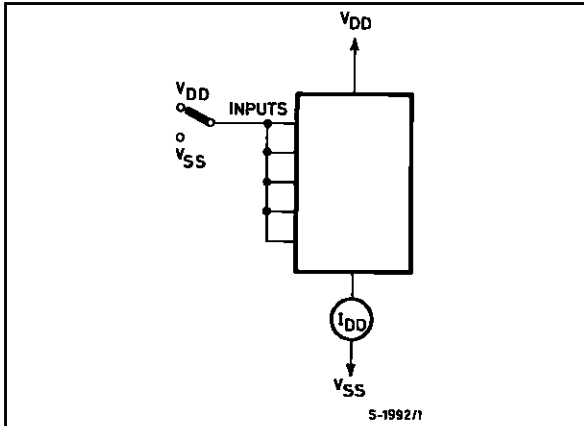

Noise Immunity.

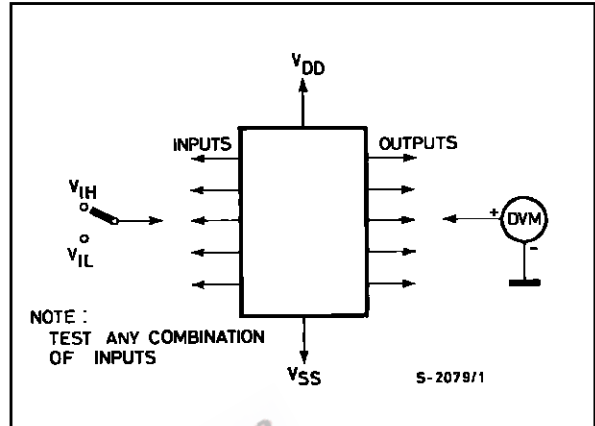

Input Leakage Current.

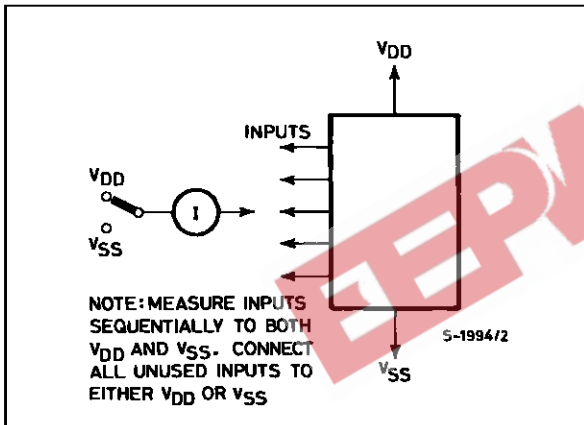

HCC/HCF4089B

Plastic DIP16 (0.25) MECHANICAL DATA

DIM.	mm			inch		
	MIN.	TYP.	MAX.	MIN.	TYP.	MAX.
a1	0.51			0.020		
B	0.77		1.65	0.030		0.065
b		0.5			0.020	
b1		0.25			0.010	
D			20			0.787
E		8.5			0.335	
e		2.54			0.100	
e3		17.78			0.700	
F			7.1			0.280
I			5.1			0.201
L		3.3			0.130	
Z			1.27			0.050

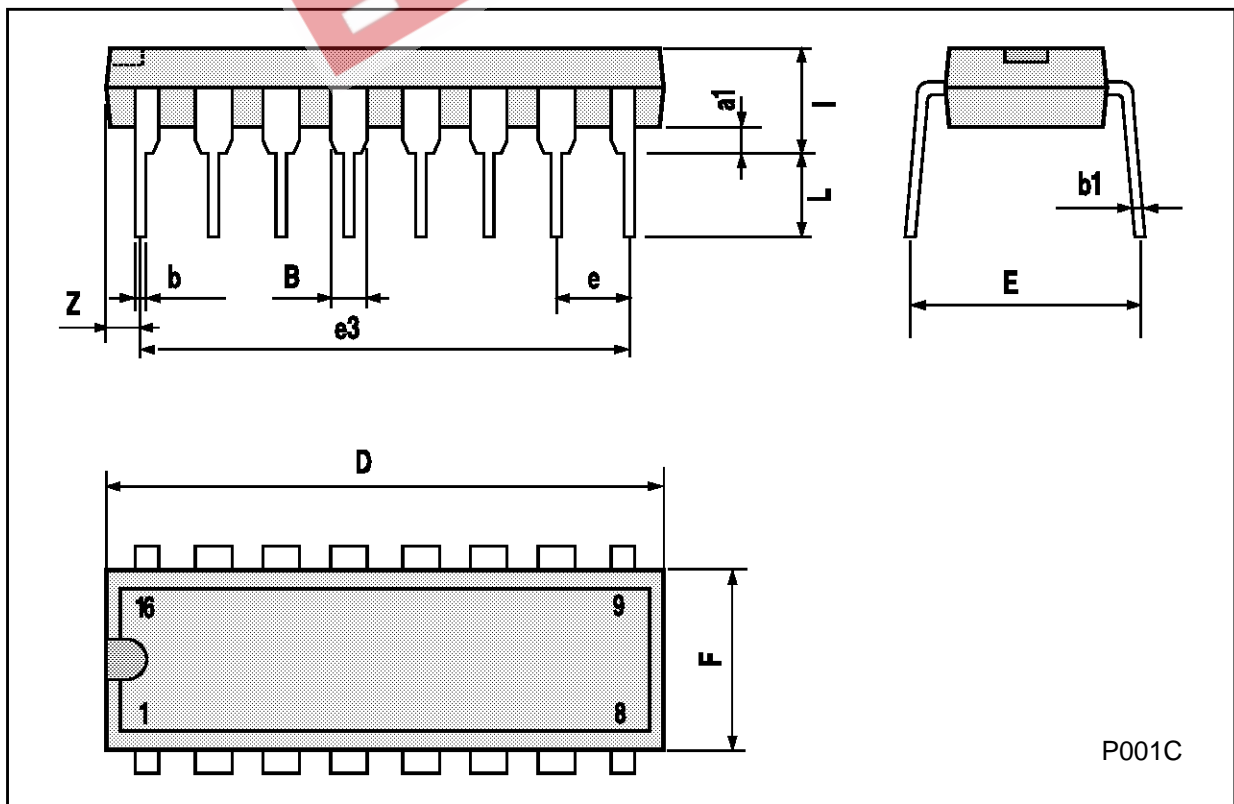

Ceramic DIP16/1 MECHANICAL DATA

DIM.	mm			inch		
	MIN.	TYP.	MAX.	MIN.	TYP.	MAX.
A			20			0.787
B			7			0.276
D		3.3			0.130	
E	0.38			0.015		
e3		17.78			0.700	
F	2.29		2.79	0.090		0.110
G	0.4		0.55	0.016		0.022
H	1.17		1.52	0.046		0.060
L	0.22		0.31	0.009		0.012
M	0.51		1.27	0.020		0.050
N			10.3			0.406
P	7.8		8.05	0.307		0.317
Q			5.08			0.200

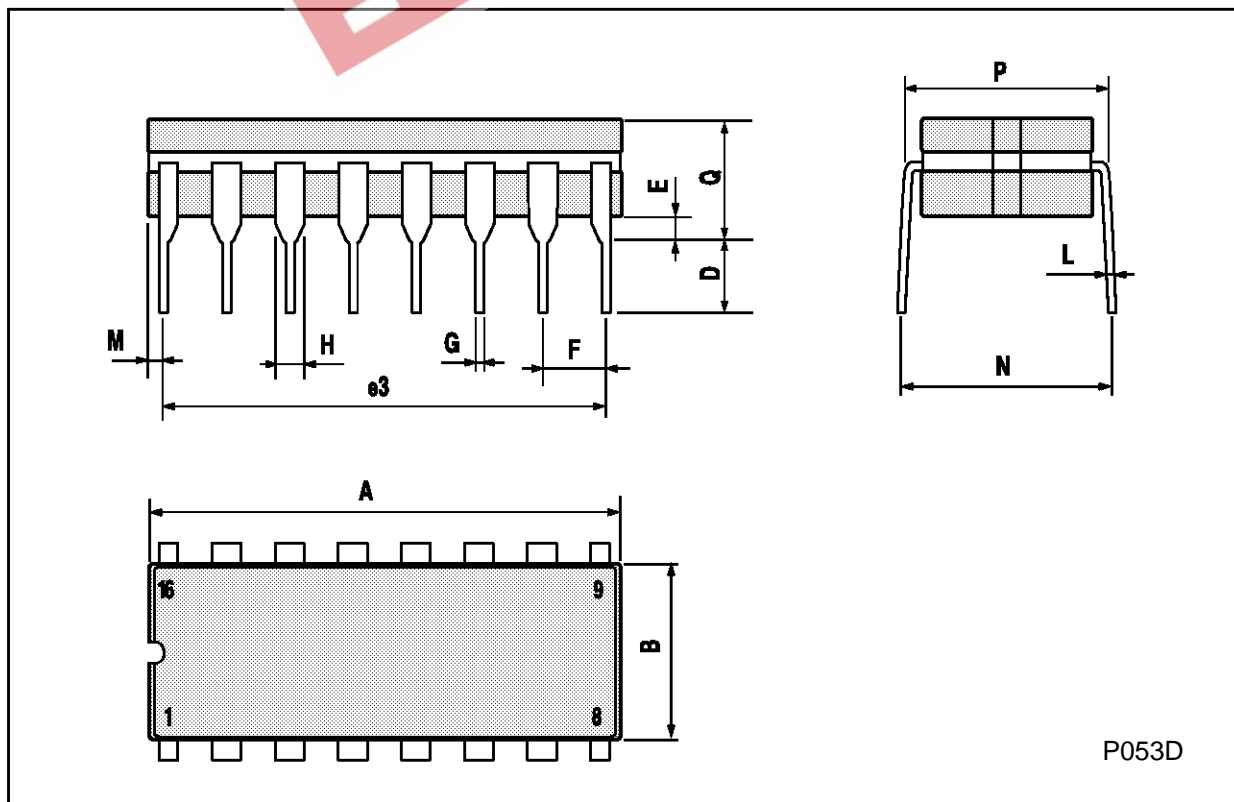

PLCC20 MECHANICAL DATA

DIM.	mm			inch		
	MIN.	TYP.	MAX.	MIN.	TYP.	MAX.
A	9.78		10.03	0.385		0.395
B	8.89		9.04	0.350		0.356
D	4.2		4.57	0.165		0.180
d1		2.54			0.100	
d2		0.56			0.022	
E	7.37		8.38	0.290		0.330
e		1.27			0.050	
e3		5.08			0.200	
F		0.38			0.015	
G			0.101			0.004
M		1.27			0.050	
M1		1.14			0.045	

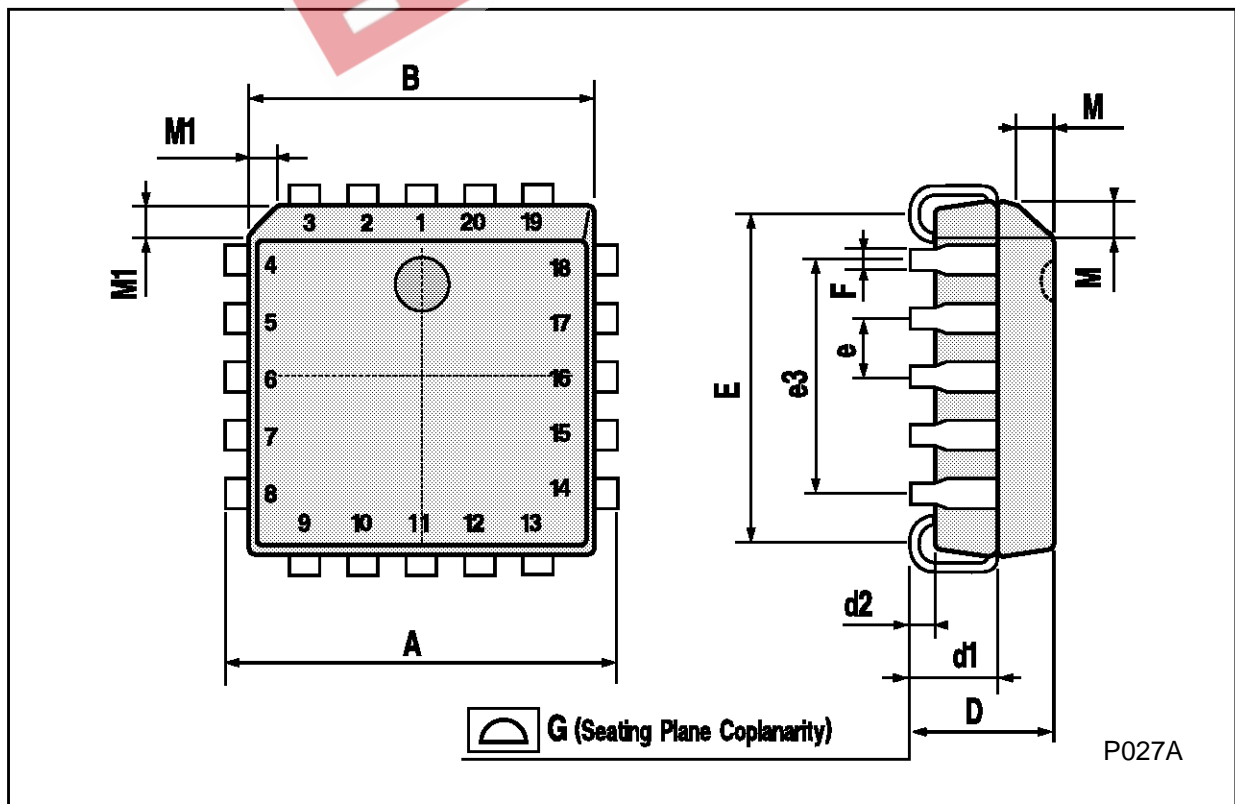

EEPW 电子產品世界
.com.cn

Information furnished is believed to be accurate and reliable. However, SGS-THOMSON Microelectronics assumes no responsibility for the consequences of use of such information nor for any infringement of patents or other rights of third parties which may result from its use. No license is granted by implication or otherwise under any patent or patent rights of SGS-THOMSON Microelectronics. Specifications mentioned in this publication are subject to change without notice. This publication supersedes and replaces all information previously supplied. SGS-THOMSON Microelectronics products are not authorized for use as critical components in life support devices or systems without express written approval of SGS-THOMSON Microelectronics.

© 1994 SGS-THOMSON Microelectronics - All Rights Reserved

SGS-THOMSON Microelectronics GROUP OF COMPANIES

Australia - Brazil - France - Germany - Hong Kong - Italy - Japan - Korea - Malaysia - Malta - Morocco - The Netherlands -
Singapore - Spain - Sweden - Switzerland - Taiwan - Thailand - United Kingdom - U.S.A