

## QUAD BILATERAL SWITCH FOR TRANSMISSION OR MULTIPLEXING OF ANALOG OR DIGITAL SIGNALS

- 15V DIGITAL OR  $\pm 7.5V$  PEAK-TO-PEAK SWITCHING
- $80\Omega$  TYPICAL ON RESISTANCE FOR 15V OPERATION
- SWITCH ON RESISTANCE MATCHED TO WITHIN  $5\Omega$  OVER 15V SIGNAL-INPUT RANGE
- ON RESISTANCE FLAT OVER FULL PEAK-TO-PEAK SIGNAL RANGE
- HIGH ON/OFF OUTPUT-VOLTAGE RATIO :  $65dB$  TYP. @  $f_{is} = 10kHz$ ,  $R_L = 10k\Omega$
- HIGH DEGREE OF LINEARITY :  $< 0.5\%$  DISTORTION TYP. @  $f_{is} = 1kHz$ ,  $V_{is} = 5V_{p-p}$ ,  $V_{DD} - V_{SS} \geq 10V$ ,  $R_L = 10k\Omega$
- EXTREMELY LOW OFF SWITCH LEAKAGE RESULTING IN VERY LOW OFFSET CURRENT AND HIGH EFFECTIVE OFF RESISTANCE ;  $10pA$  TYP. @  $V_{DD} - V_{SS} = 10V$ ,  $T_A = 25^\circ C$
- EXTREMELY HIGH CONTROL INPUT IMPEDANCE (control circuit isolated from signal circuit) :  $10^{12}\Omega$  TYP.
- LOW CROSSTALK BETWEEN SWITCHES :  $-50dB$  TYP. @  $f_{is} = 0.9MHz$ ,  $R_L = 1k\Omega$
- MATCHED CONTROL-INPUT TO SIGNAL-OUTPUT CAPACITANCE : REDUCES OUTPUT SIGNAL TRANSIENTS
- FREQUENCY RESPONSE, SWITCH ON =  $40MHz$  (typ.)
- QUIESCENT CURRENT SPECIFIED TO 20V FOR HCC DEVICE
- 5V, 10V, AND 15V PARAMETRIC RATINGS
- INPUT CURRENT OF  $100nA$  AT 18V AND  $25^\circ C$  FOR HCC DEVICE
- 100% TESTED FOR QUIESCENT CURRENT
- MEETS ALL REQUIREMENTS OF JEDEC TENTATIVE STANDARD N<sup>o</sup>. 13A, "STANDARD SPECIFICATIONS FOR DESCRIPTION OF "B" SERIES CMOS DEVICES"

### DESCRIPTION

The **HCC4066B** (extended temperature range) and **HCF4066B** (intermediate temperature range) are monolithic integrated circuits, available in 14-lead dual in-line plastic or ceramic package and plastic micropackage. The **HCC/HCF4066B** is a quad bilateral switch intended for the transmission or multiplexing of analog or digital signals. It is pin-for-

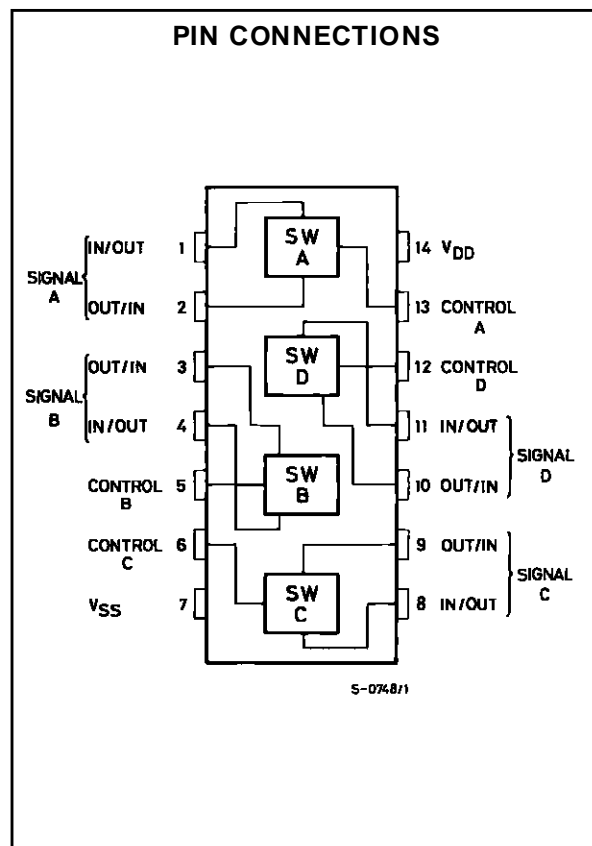
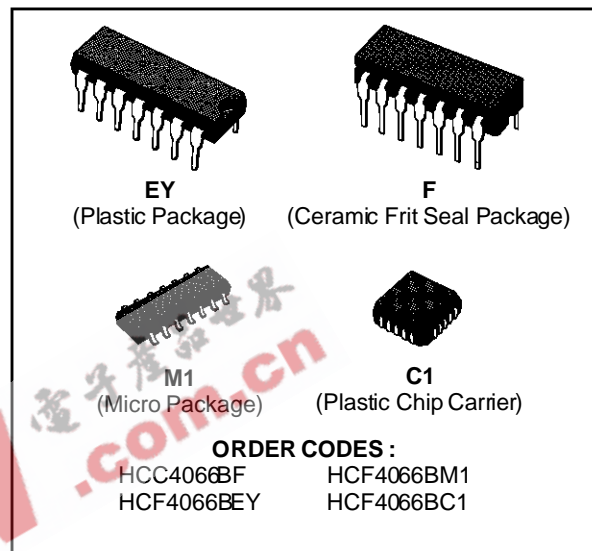

## HCC/HCF4066B

pin compatible with **HCC/HCF4016B**, but exhibits a much lower ON resistance. In addition, the ON resistance is relatively constant over the full input-signal range. The **HCC/HCF4066B** consists of four independent bilateral switches. A single control signal is required per switch. Both the p and the n device in a given switch are biased ON or OFF simultaneously by the control signal. As shown in schematic diagram, the well of the n-channel device on each switch is either tied to the input when the switch is ON or to  $V_{SS}$  when the switch is OFF. This

configuration eliminates the variation of the switch-transistor threshold voltage with input signal, and thus keeps the ON resistance low over the full operating-signal range. The advantages over single-channel switches include peak input signal voltage swings equal to the full supply voltage, and more constant ON impedance over the input-signal range. For sample-and-hold applications, however, the **HCC/HCF4016B** is recommended.

### SCHEMATIC DIAGRAM

1 OF 4 IDENTICAL SWITCHES AND ITS ASSOCIATED CONTROL CIRCUITRY.

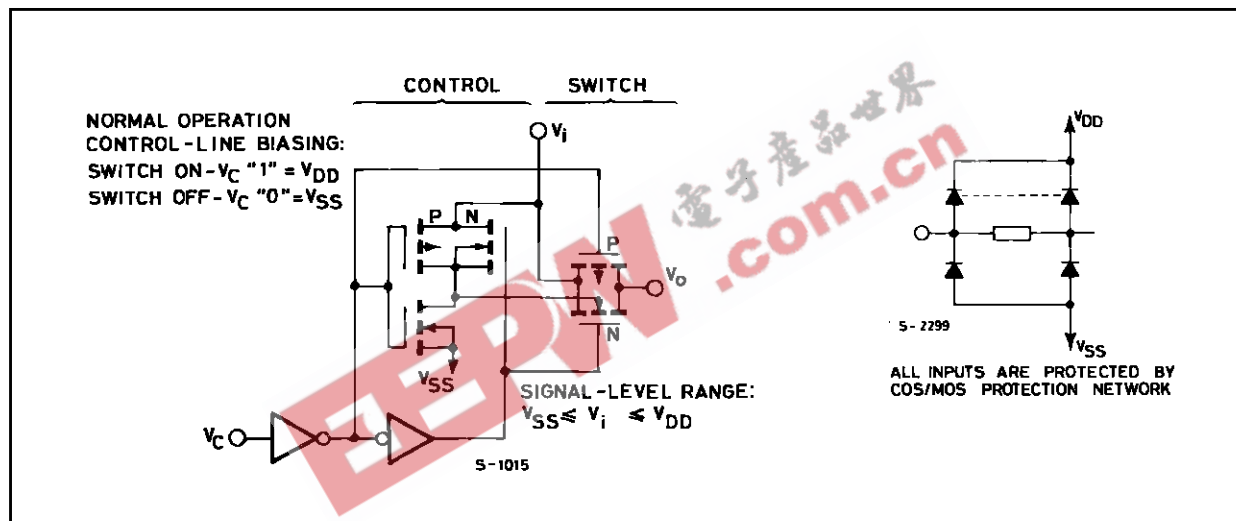

### ABSOLUTE MAXIMUM RATINGS

Symbol	Parameter	Value	Unit
$V_{DD}^*$	Supply Voltage : <b>HCC</b> Types <b>HCF</b> Types	- 0.5 to + 20 - 0.5 to + 18	V V
$V_i$	Input Voltage	- 0.5 to $V_{DD} + 0.5$	V
$I_i$	DC Input Current (any one input)	$\pm 10$	mA
$P_{tot}$	Total Power Dissipation (per package) Dissipation per Output Transistor for $T_{op}$ = Full Package-temperature Range	200 100	mW mW
$T_{op}$	Operating Temperature : <b>HCC</b> Types <b>HCF</b> Types	- 55 to + 125 - 40 to + 85	$^{\circ}C$ $^{\circ}C$
$T_{stg}$	Storage Temperature	- 65 to + 150	$^{\circ}C$

Stresses above those listed under "Absolute Maximum Ratings" may cause permanent damage to the device. This is a stress rating only and functional operation of the device at these or any other conditions above those indicated in the operational sections of this specification is not implied. Exposure to absolute maximum rating conditions for external periods may affect device reliability.  
 \* All voltage values are referred to  $V_{SS}$  pin voltage.

## RECOMMENDED OPERATING CONDITIONS

Symbol	Parameter	Value	Unit
V <sub>DD</sub>	Supply Voltage : <b>HCC</b> Types	3 to 18	V
	<b>HCF</b> Types	3 to 15	V
V <sub>I</sub>	Input Voltage	0 to V <sub>DD</sub>	V
T <sub>op</sub>	Operating Temperature : <b>HCC</b> Types	- 55 to + 125	°C
	<b>HCF</b> Types	- 40 to + 85	°C

## ELECTRICAL CHARACTERISTICS

(T<sub>amb</sub> = 25°C, typical temperature coefficient for all V<sub>DD</sub> values is 0,3%/°C)

Symbol	Parameter	Test Conditions				Value						Unit
		V <sub>I</sub> (V)	V <sub>DD</sub> (V)	T <sub>Low</sub> *		25°C			T <sub>High</sub> *			
				Min.	Max.	Min.	Typ.	Max.	Min.	Max.		
I <sub>L</sub>	Quiescent Device Current (all switches ON or all switches OFF)	HCC Types	0/ 5	5		0.25	0.01	0.25		7.5	μA	
			0/10	10		0.5	0.01	0.5		15		
			0/15	15		1	0.01	1		30		
		0/20	20		5	0.02	5		150			
		HCF Types	0/ 5	5		1	0.01	1		7.5		
			0/10	10		2	0.01	2		15		
0/15	15			4	0.01	4		30				
<b>SIGNAL INPUTS (V<sub>is</sub>) and Outputs (V<sub>os</sub>)</b>												
R <sub>ON</sub>	On Resistance	HCC Types	V <sub>C</sub> = V <sub>DD</sub> R <sub>L</sub> = 10kΩ Return to V <sub>DD</sub> - V <sub>SS</sub> 2 V <sub>is</sub> = V <sub>SS</sub> to V <sub>DD</sub>	5		800		470	1050		1300	Ω
				10		310		180	400		550	
				15		200		125	240		320	
		HCF Types		5		850		470	1050		1200	
				10		330		180	400		500	
				15		210		125	240		300	
ΔON	Resistance between any 2 Switches, ΔR <sub>ON</sub>		R <sub>L</sub> 10kΩ, V <sub>C</sub> = V <sub>DD</sub>	5				15			Ω	
				10				10				
				15				5				
TDH	Total Harmonic Distorsion		V <sub>C</sub> = V <sub>DD</sub> = 5V, V <sub>SS</sub> = - 5V, V <sub>is</sub> (p-p) = 5V (sine wave centered in 0V) R <sub>L</sub> = 10kΩ, f <sub>is</sub> = 1kHz sine wave					0.4			%	
	- 3 dB Cutoff Frequency (switch on)		V <sub>C</sub> = V <sub>DD</sub> = 5V, V <sub>SS</sub> = - 5V, V <sub>is</sub> (p-p) = 5V (sine wave centured on 0V) R <sub>L</sub> = 1kΩ					40			MHz	

\* T<sub>Low</sub> = - 55°C for **HCC** device : - 40°C for **HCF** device.\* T<sub>High</sub> = + 125°C for **HCC** device : + 85°C for **HCF** device.The Noise Margin for both "1" and "0" level is : 1V min. with V<sub>DD</sub> = 5V, 2V min. with V<sub>DD</sub> = 10V, 2.5V min. with V<sub>DD</sub> = 15V.

## HCC/HCF4066B

### ELECTRICAL CHARACTERISTICS (continued)

Symbol	Parameter	Test Conditions		Value						Unit		
			V <sub>DD</sub> (V)	T <sub>Low</sub> *		25°C			T <sub>High</sub> *			
				Min.	Max.	Min.	Typ.	Max.	Min.		Max.	
	- 50 dB Feedthrough Frequency (switch off)	V <sub>C</sub> = V <sub>SS</sub> = - 5V, V <sub>is</sub> (p-p) = 5V (sine wave centured on 0V) R <sub>L</sub> = 1kΩ					1				MHz	
	- 50 dB Crosstalk Frequency	V <sub>C</sub> (A) = V <sub>DD</sub> = + 5V V <sub>C</sub> (B) = V <sub>SS</sub> = - 5V V <sub>is</sub> (A) = 5Vp-p, 50Ω source R <sub>L</sub> = 1kΩ					8				MHz	
t <sub>pd</sub>	Propagati on Delay (signal input to signal output)	R <sub>L</sub> = 200kΩ V <sub>C</sub> = V <sub>DD</sub> , V <sub>SS</sub> = GND, C <sub>L</sub> = 50pF, V <sub>is</sub> = 10V (square wave centured on 5V) t <sub>r</sub> , t <sub>f</sub> = 20ns		5			20	40			ns	
				10			10	20				
				15			7	15				
C <sub>is</sub>	Input Capacitance	V <sub>DD</sub> = + 5V V <sub>C</sub> = V <sub>SS</sub> = - 5V					8			pF		
C <sub>os</sub>	Output Capacitance						8					
C <sub>ios</sub>	Feedthrough						0.5					
	Input/Output Leakage Current Switch OFF	HCC Types	V <sub>C</sub> = 0V V <sub>is</sub> = 18V ; V <sub>os</sub> = 0V V <sub>is</sub> = 0V ; V <sub>os</sub> = 18V	18		± 0.1	±10 <sup>-3</sup>	± 0.1		± 1	μA	
		HCF Types	V <sub>C</sub> = 0V V <sub>is</sub> = 15V ; V <sub>os</sub> = 0V V <sub>is</sub> = 0V ; V <sub>os</sub> = 15V	15		± 0.3	±10 <sup>-3</sup>	± 0.3		± 1		
<b>CONTROL (V<sub>C</sub>)</b>												
V <sub>ILC</sub>	Control Input Low Voltage	I <sub>is</sub>   < 10μA V <sub>is</sub> = V <sub>SS</sub> , V <sub>os</sub> = V <sub>DD</sub> and V <sub>is</sub> = V <sub>DD</sub> , V <sub>os</sub> = V <sub>SS</sub>		5		1			1		1	V
				10		2			2		2	
				15		2			2		2	
V <sub>IHC</sub>	Control Input High Voltage			5	3.5		3.5			3.5		V
				10	7		7			7		
				15	11		11			11		
I <sub>IH</sub> I <sub>IL</sub>	Input Leakage Current	HCC Types	V <sub>is</sub> ≤ V <sub>DD</sub> V <sub>DD</sub> - V <sub>SS</sub> = 18V	18		± 0.1	±10 <sup>-5</sup>	± 0.1		± 1	μA	
		HCF Types	V <sub>DD</sub> - V <sub>SS</sub> = 15V V <sub>CC</sub> ≤ V <sub>DD</sub> - V <sub>SS</sub>	15		± 0.3	±10 <sup>-5</sup>	± 0.3		± 1		

\* T<sub>Low</sub> = - 55°C for **HCC** device : - 40°C for **HCF** device.

\* T<sub>High</sub> = + 125°C for **HCC** device : + 85°C for **HCF** device.

The Noise Margin for both "1" and "0" level is : 1V min. with V<sub>DD</sub> = 5V, 2V min. with V<sub>DD</sub> = 10V, 2.5V min. with V<sub>DD</sub> = 15V.

**ELECTRICAL CHARACTERISTICS** (continued)

Symbol	Parameter	Test Conditions	V <sub>DD</sub> (V)	Value						Unit	
				T <sub>Low</sub> *		25°C			T <sub>High</sub> *		
				Min.	Max.	Min.	Typ.	Max.	Min.		Max.
	Crosstalk (control input to signal output)	V <sub>C</sub> = 10V (sq. wave) t <sub>r</sub> , t <sub>f</sub> = 20ns R <sub>L</sub> = 10kΩ	10				50				mV
	Turn-on Propagation Delay	V <sub>IN</sub> = V <sub>DD</sub> t <sub>r</sub> , t <sub>f</sub> = 20ns C <sub>L</sub> = 50pF R <sub>L</sub> = 1kΩ	5				35	70			ns
10						20	40				
15						15	30				
	Control Input Repetition Rate	V <sub>is</sub> = V <sub>DD</sub> , V <sub>SS</sub> = GND R <sub>L</sub> = 1kΩ to gnd C <sub>L</sub> = 50pF V <sub>C</sub> = 10V (square wave centured on 5V) t <sub>r</sub> , t <sub>f</sub> = 20ns V <sub>os</sub> = 1/2V <sub>os</sub> @ 1kHz	5				6				MHz
10						9					
15						9.5					
C <sub>I</sub>	Input Capacitance	Any Input					5	7.5			pF

\* T<sub>Low</sub> = - 55°C for HCC device : - 40°C for HCF device.  
 \* T<sub>High</sub> = + 125°C for HCC device : + 85°C for HCF device.  
 The Noise Margin for both "1" and "0" level is : 1V min. with V<sub>DD</sub> = 5V, 2V min. with V<sub>DD</sub> = 10V, 2.5V min. with V<sub>DD</sub> = 15V.

**TYPICAL APPLICATIONS**

**BIDIRECTIONAL SIGNAL TRANSMISSION VIA DIGITAL CONTROL LOGIC**

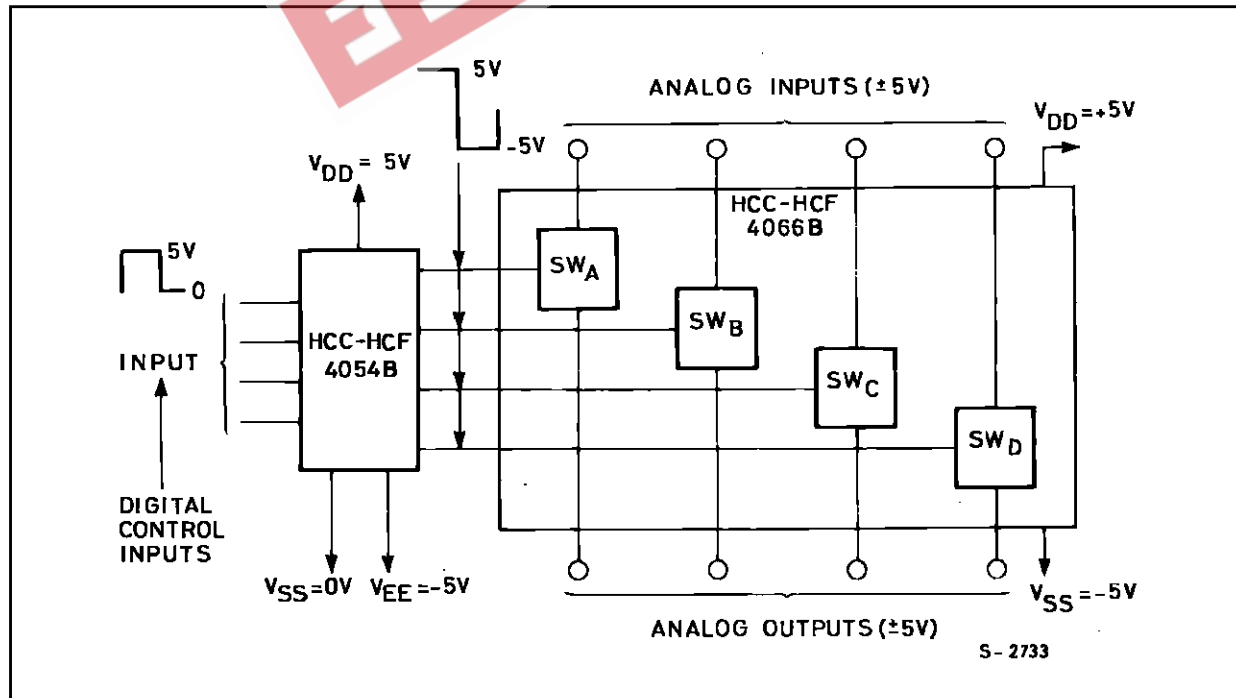

# HCC/HCF4066B

## TYPICAL APPLICATIONS (continued)

4-CHANNEL PAM MULTIPLEX SYSTEM DIAGRAM.

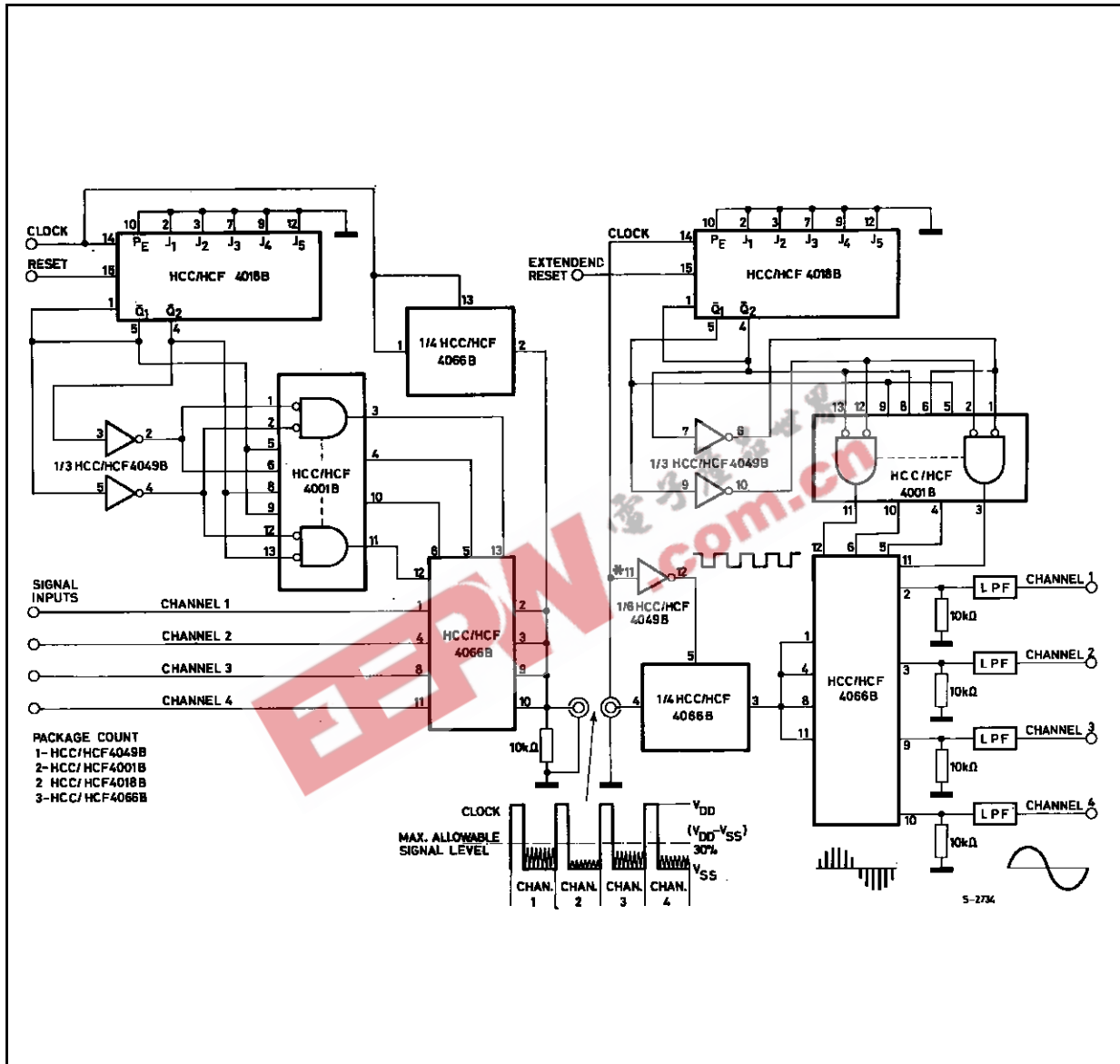

## Plastic DIP14 MECHANICAL DATA

DIM.	mm			inch		
	MIN.	TYP.	MAX.	MIN.	TYP.	MAX.
a1	0.51			0.020		
B	1.39		1.65	0.055		0.065
b		0.5			0.020	
b1		0.25			0.010	
D			20			0.787
E		8.5			0.335	
e		2.54			0.100	
e3		15.24			0.600	
F			7.1			0.280
I			5.1			0.201
L		3.3			0.130	
Z	1.27		2.54	0.050		0.100

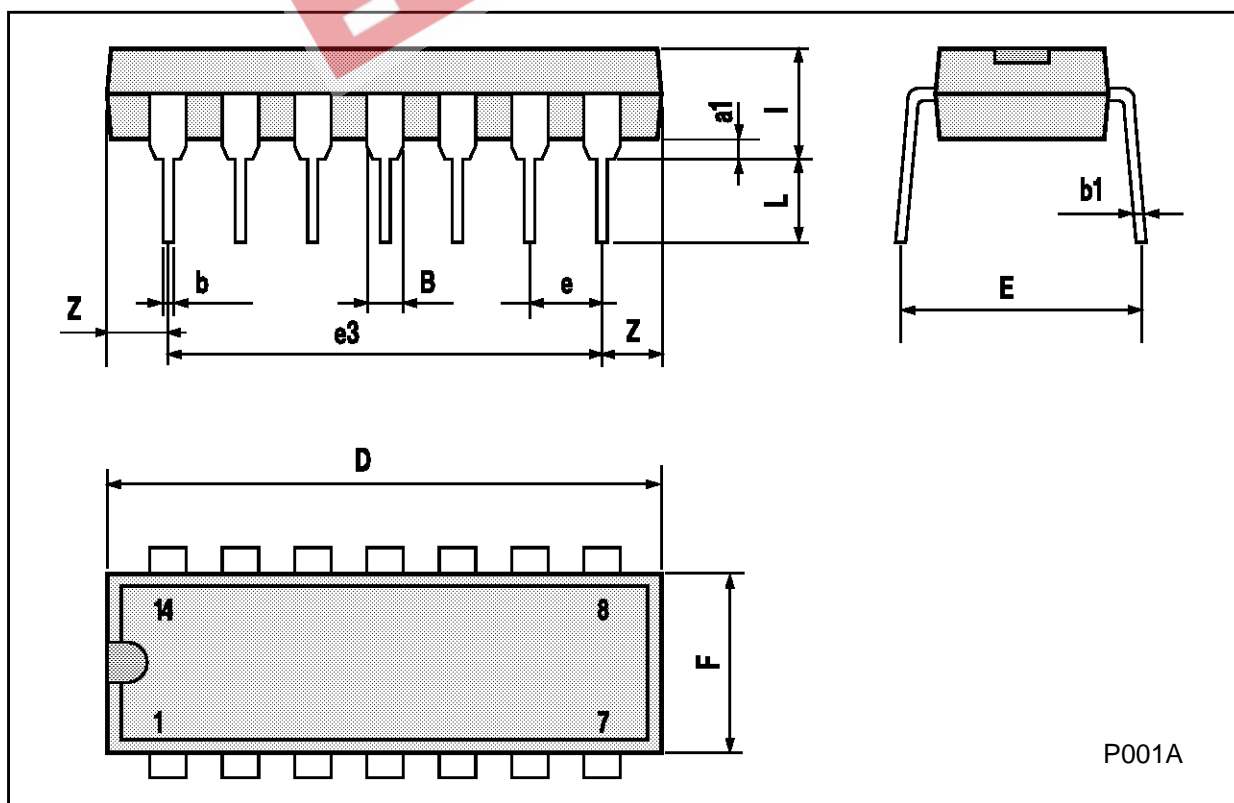

P001A

HCC/HCF4066B

**Ceramic DIP14/1 MECHANICAL DATA**

DIM.	mm			inch		
	MIN.	TYP.	MAX.	MIN.	TYP.	MAX.
A			20			0.787
B			7.0			0.276
D		3.3			0.130	
E	0.38			0.015		
e3		15.24			0.600	
F	2.29		2.79	0.090		0.110
G	0.4		0.55	0.016		0.022
H	1.17		1.52	0.046		0.060
L	0.22		0.31	0.009		0.012
M	1.52		2.54	0.060		0.100
N			10.3			0.406
P	7.8		8.05	0.307		0.317
Q			5.08			0.200

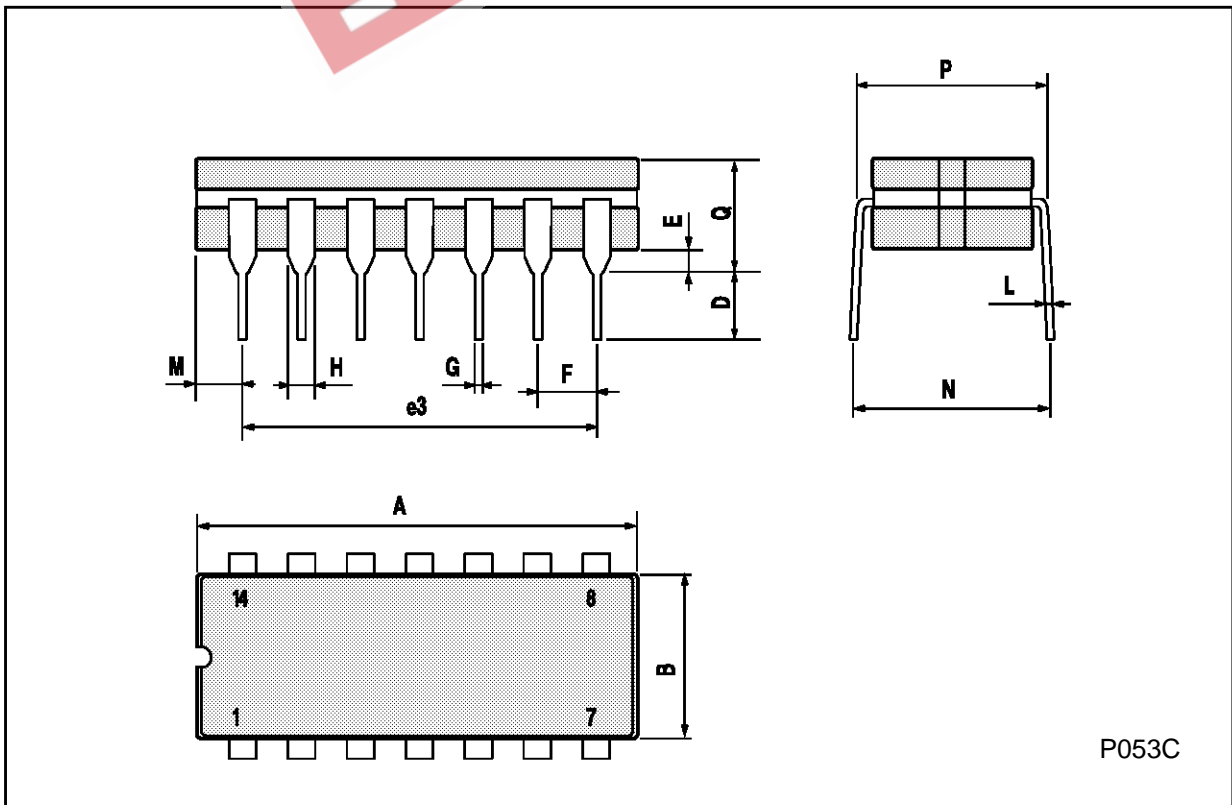



## SO14 MECHANICAL DATA

DIM.	mm			inch		
	MIN.	TYP.	MAX.	MIN.	TYP.	MAX.
A			1.75			0.068
a1	0.1		0.2	0.003		0.007
a2			1.65			0.064
b	0.35		0.46	0.013		0.018
b1	0.19		0.25	0.007		0.010
C		0.5			0.019	
c1	45° (typ.)					
D	8.55		8.75	0.336		0.344
E	5.8		6.2	0.228		0.244
e		1.27			0.050	
e3		7.62			0.300	
F	3.8		4.0	0.149		0.157
G	4.6		5.3	0.181		0.208
L	0.5		1.27	0.019		0.050
M			0.68			0.026
S	8° (max.)					

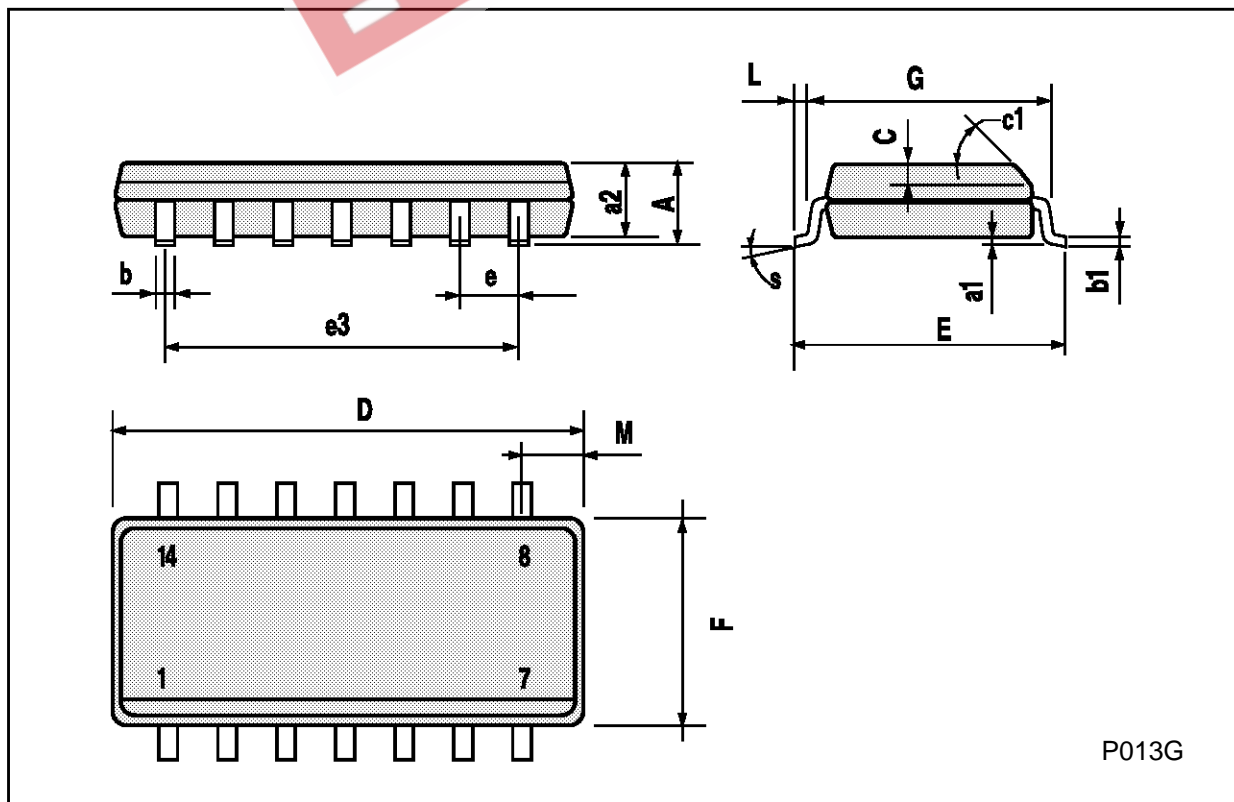

**PLCC20 MECHANICAL DATA**

DIM.	mm			inch		
	MIN.	TYP.	MAX.	MIN.	TYP.	MAX.
A	9.78		10.03	0.385		0.395
B	8.89		9.04	0.350		0.356
D	4.2		4.57	0.165		0.180
d1		2.54			0.100	
d2		0.56			0.022	
E	7.37		8.38	0.290		0.330
e		1.27			0.050	
e3		5.08			0.200	
F		0.38			0.015	
G			0.101			0.004
M		1.27			0.050	
M1		1.14			0.045	

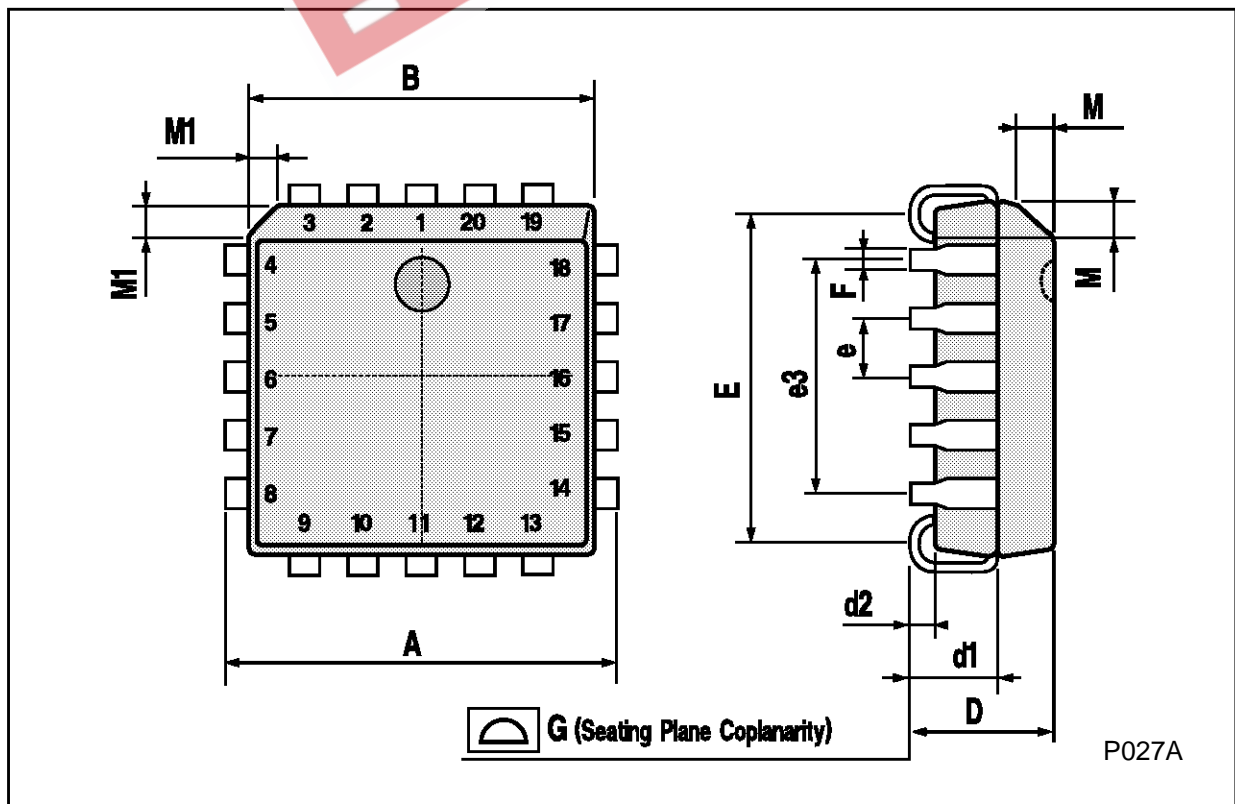

EEPW 电子產品世界  
.com.cn

Information furnished is believed to be accurate and reliable. However, SGS-THOMSON Microelectronics assumes no responsibility for the consequences of use of such information nor for any infringement of patents or other rights of third parties which may result from its use. No license is granted by implication or otherwise under any patent or patent rights of SGS-THOMSON Microelectronics. Specifications mentioned in this publication are subject to change without notice. This publication supersedes and replaces all information previously supplied. SGS-THOMSON Microelectronics products are not authorized for use as critical components in life support devices or systems without express written approval of SGS-THOMSON Microelectronics.

© 1994 SGS-THOMSON Microelectronics - All Rights Reserved

SGS-THOMSON Microelectronics GROUP OF COMPANIES  
Australia - Brazil - France - Germany - Hong Kong - Italy - Japan - Korea - Malaysia - Malta - Morocco - The Netherlands -  
Singapore - Spain - Sweden - Switzerland - Taiwan - Thailand - United Kingdom - U.S.A