

Single Channel, High Speed Optocouplers

Technical Data

6N135/6
HCNW135/6
HCNW4502/3
HCPL-2502
HCPL-0452/3
HCPL-0500/1
HCPL-4502/3

Features

- **15 kV/μs Minimum Common Mode Transient Immunity at $V_{CM} = 1500\text{ V}$ (4503/0453)**
- **High Speed: 1 Mb/s**
- **TTL Compatible**
- **Available in 8-Pin DIP, SO-8, Widebody Packages**
- **Open Collector Output**
- **Guaranteed Performance from Temperature: 0°C to 70°C**
- **Safety Approval**
 UL Recognized – 3750 V rms for 1 minute (5000 V rms for 1 minute for HCNW and Option 020 devices) per UL1577
 CSA Approved
 IEC/EN/DIN EN 60747-5-2 Approved
 $-V_{IORM} = 630\text{ V peak}$ for HCPL-4503#060
 $-V_{IORM} = 1414\text{ V peak}$ for HCNW devices
- **Dual Channel Version Available (253X/4534/053X/0534)**
- **MIL-PRF-38534 Hermetic Version Available (55XX/65XX/4N55)**

Applications

- **High Voltage Insulation**
- **Video Signal Isolation**
- **Power Transistor Isolation in Motor Drives**
- **Line Receivers**
- **Feedback Element in Switched Mode Power Supplies**
- **High Speed Logic Ground Isolation – TTL/TTL, TTL/CMOS, TTL/LSTTL**
- **Replaces Pulse Transformers**
- **Replaces Slow Phototransistor Isolators**
- **Analog Signal Ground Isolation**

Description

These diode-transistor optocouplers use an insulating layer between a LED and an integrated photodetector to provide electrical insulation between input and output. Separate connections for the photodiode bias and output-transistor collector increase the speed up to a hundred times that of a conventional phototransistor coupler by reducing the base-collector capacitance.

Functional Diagram

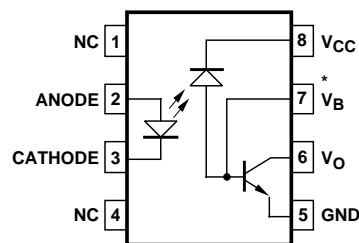

* NOTE: FOR 4502/3, 0452/3, PIN 7 IS NOT CONNECTED.

LED	V_O
ON	LOW
OFF	HIGH

A 0.1 μF bypass capacitor must be connected between pins 5 and 8.

CAUTION: It is advised that normal static precautions be taken in handling and assembly of this component to prevent damage and/or degradation which may be induced by ESD.

These single channel optocouplers are available in 8-Pin DIP, SO-8 and Widebody package configurations.

The 6N135, HCPL-0500, and HCNW135 are for use in TTL/CMOS, TTL/LSTTL or wide bandwidth analog applications. Current transfer ratio (CTR) for these devices is 7% minimum at $I_F = 16$ mA.

The 6N136, HCPL-2502, HCPL-0501, and HCNW136 are designed for high speed TTL/TTL applications. A standard 16 mA TTL sink current through the input LED will provide enough

output current for 1 TTL load and a 5.6 k Ω pull-up resistor. CTR for these devices is 19% minimum at $I_F = 16$ mA.

The HCPL-4502, HCPL-0452, and HCNW4502 provide the electrical and switching performance of the 6N136, HCPL-0501, and HCNW136 with increased ESD protection.

The HCPL-4503, HCPL-0453, and HCNW4503 are similar to the HCPL-4502, HCPL-0452, and HCNW4502 optocouplers but have increased common mode transient immunity of 15 kV/ μ s minimum at $V_{CM} = 1500$ V guaranteed.

Schematic

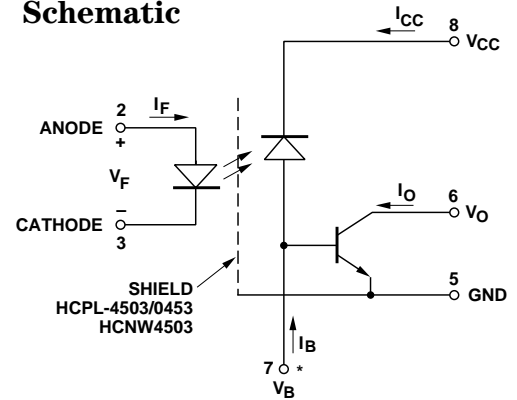

* NOTE: FOR HCPL-4502/3, HCPL-0452/3, HCNW4502/3, PIN 7 IS NOT CONNECTED.

Selection Guide

Minimum CMR		Current Transfer Ratio (%)	8-Pin DIP (300 Mil)		Small-Outline SO-8		Widebody (400 Mil)	Hermetic
dV/dt (V/ μ s)	V _{CM} (V)		Single Channel Package	Dual Channel Package*	Single Channel Package	Dual Channel Package*	Single Channel Package	Single and Dual Channel Packages*
1,000	10	7	6N135	HCPL-2530	HCPL-0500	HCPL-0530	HCNW135	
		19	6N136 HCPL-4502†	HCPL-2531	HCPL-0501 HCPL-0452†	HCPL-0531	HCNW136 HCNW4502†	
		15	HCPL-2502					
15,000	1500	19	HCPL-4503†	HCPL-4534	HCPL-0453†	HCPL-0534	HCNW4503†	
1,000	10	9						HCPL-55XX HCPL-65XX 4N55

*Technical data for these products are on separate Agilent publications.

†Pin 7, transistor base, is not connected.

Ordering Information

Specify Part Number followed by Option Number (if desired).

Example:

HCPL-4503#XXXX

- 020 = UL 5000 V rms/1 Minute Option*
- 060 = IEC/EN/DIN EN 60747-5-2 V_{IORM} = 630 V_{peak} Option**
- 300 = Gull Wing Surface Mount Option†
- 500 = Tape and Reel Packaging Option
- XXXE = Lead Free Option

Option data sheets available. Contact your Agilent sales representative or authorized distributor for information.

*For 6N135/6 and HCPL-4502/3 only.

**For HCPL-4503 only. Combination of Option 020 and Option 060 is not available.

†Gull wing surface mount option applies to through hole parts only.

Remarks: The notation “#” is used for existing products, while (new) products launched since 15th July 2001 and lead free option will use “-”

Package Outline Drawings

8-Pin DIP Package (6N135/6, HCPL-4502/3, HCPL-2502)

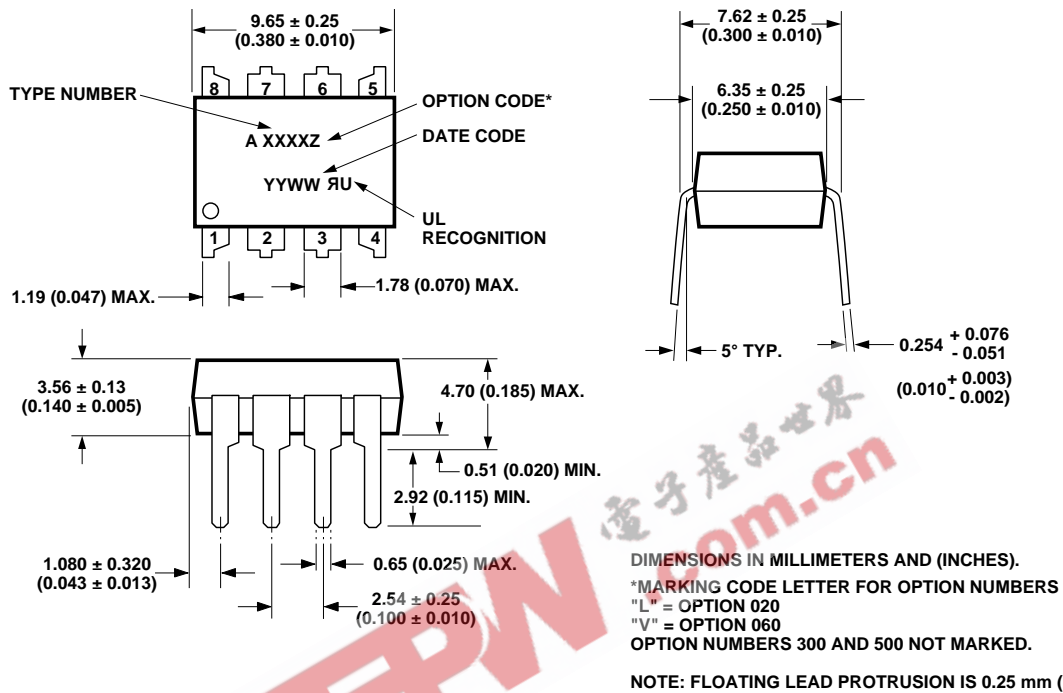

8-Pin DIP Package with Gull Wing Surface Mount Option 300 (6N135/6, HCPL-4502/3)

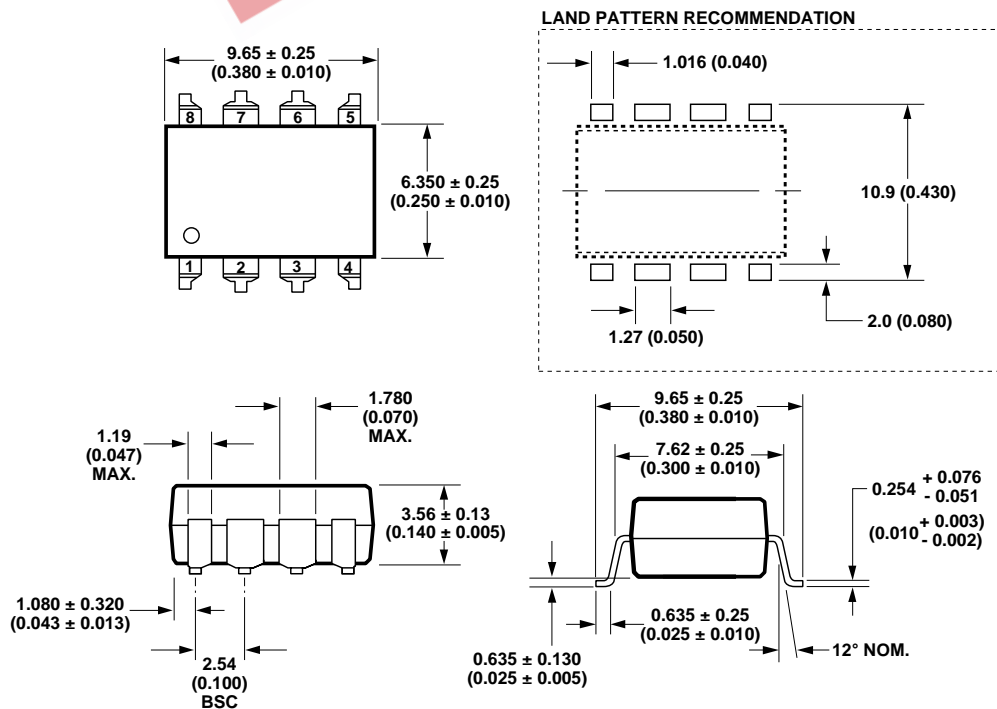

Small Outline SO-8 Package (HCPL-0500/1, HCPL-0452/3)

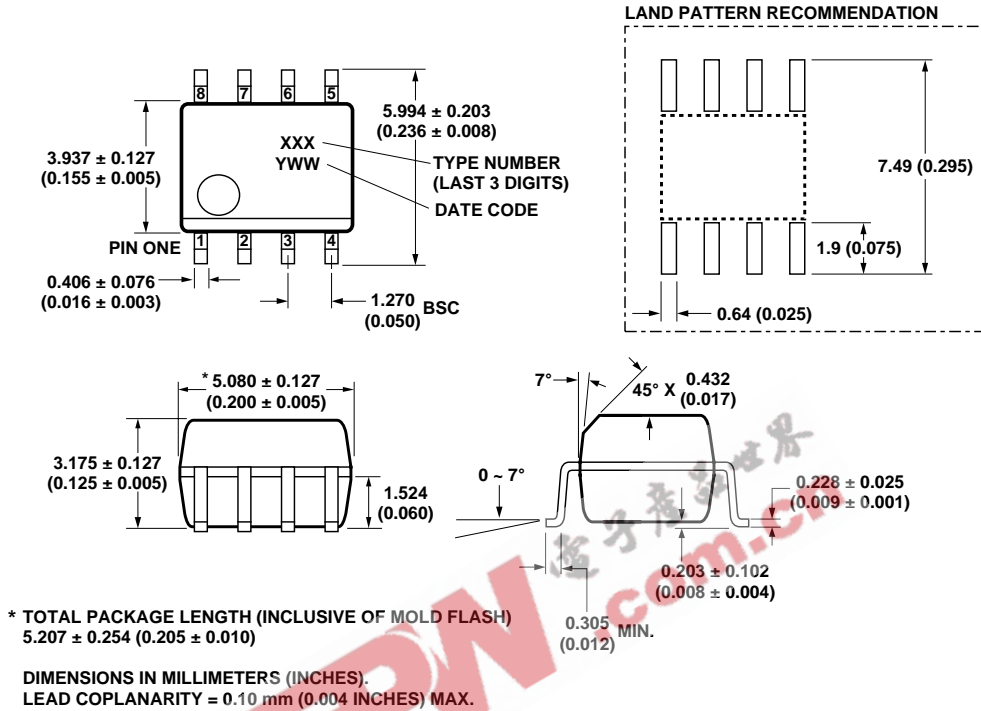

8-Pin Widebody DIP Package (HCNW135/6, HCNW4502/3)

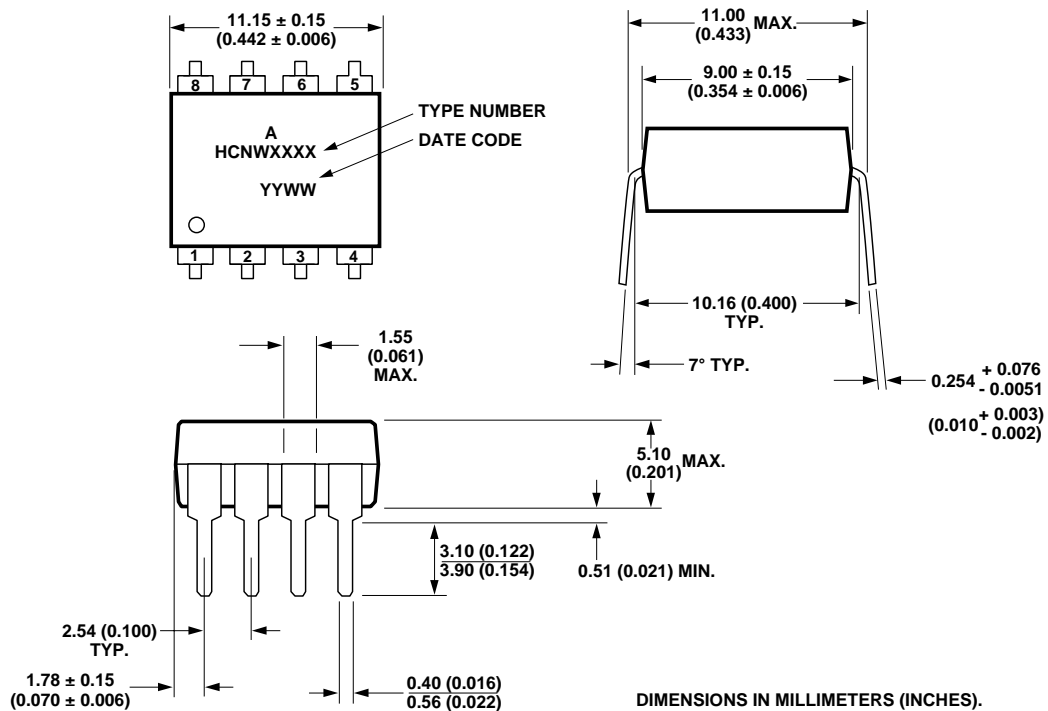

8-Pin Widebody DIP Package with Gull Wing Surface Mount Option 300 (HCNW135/6, HCNW4502/3)

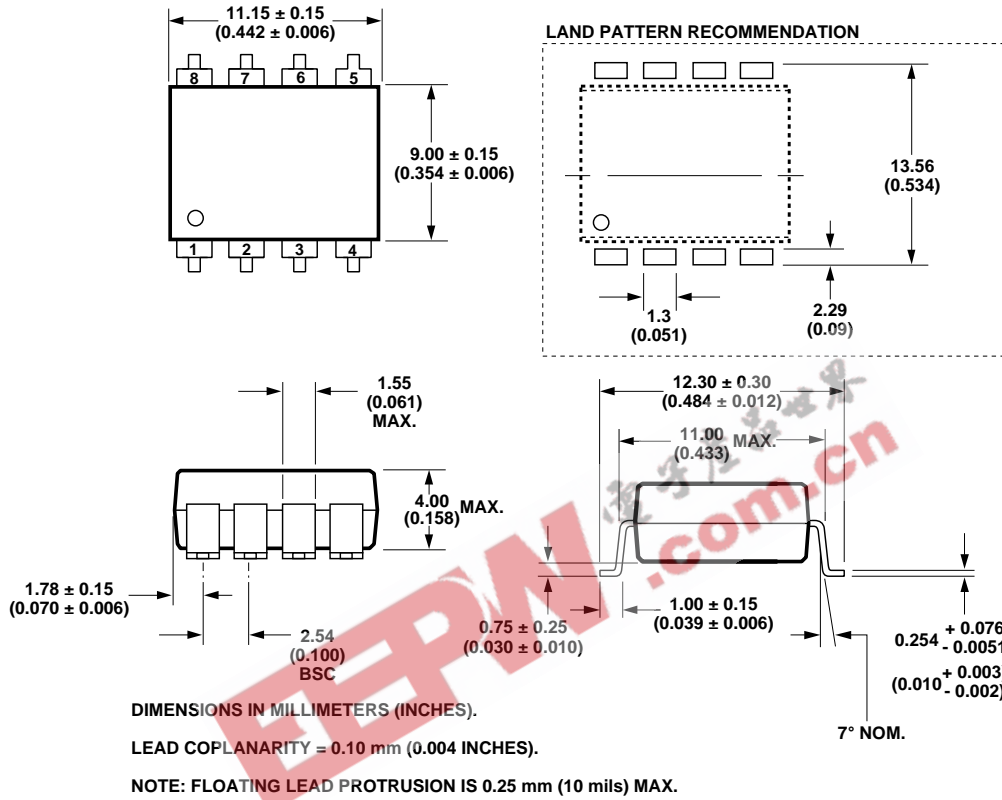

Solder Reflow Temperature Profile

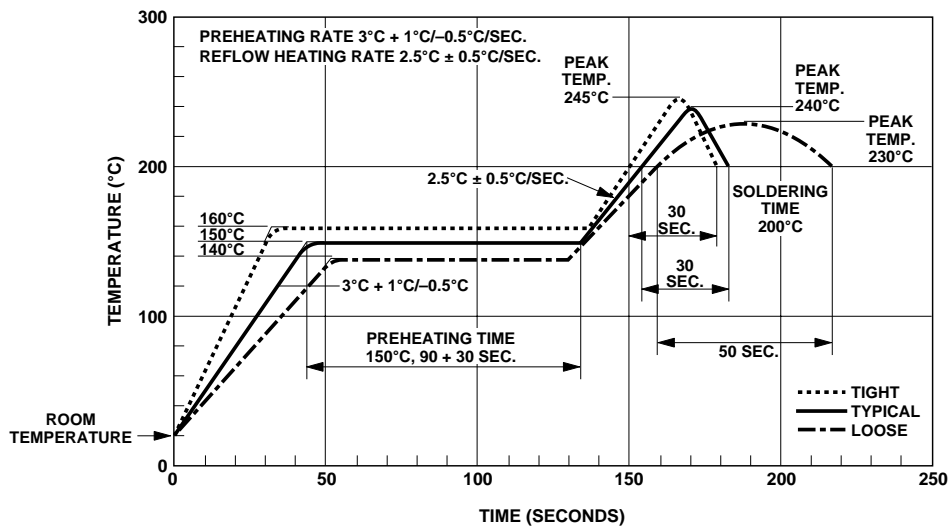

Recommended Pb-Free IR Profile

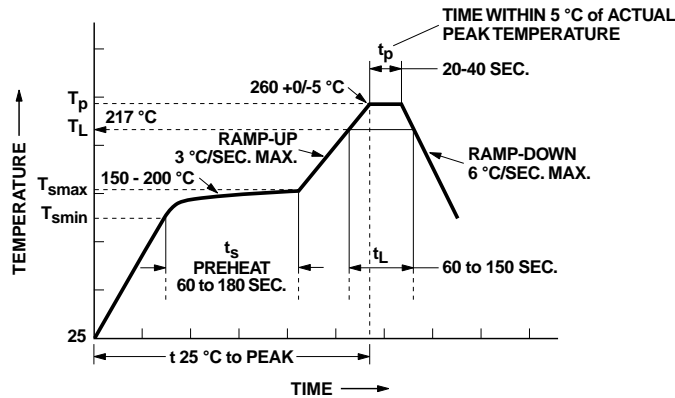

NOTES:
 THE TIME FROM 25 °C TO PEAK TEMPERATURE = 8 MINUTES MAX.
 $T_{smax} = 200\text{ °C}$, $T_{smin} = 150\text{ °C}$

Regulatory Information

The devices contained in this data sheet have been approved by the following organizations:

UL

Recognized under UL 1577, Component Recognition Program, File E55361.

CSA

Approved under CSA Component Acceptance Notice #5, File CA 88324.

IEC/EN/DIN EN 60747-5-2

Approved under IEC 60747-5-2:1997 + A1:2002
 EN 60747-5-2:2001 + A1:2002
 DIN EN 60747-5-2 (VDE 0884 Teil 2):2003-01
 (HCNW and Option 060 only)

Insulation and Safety Related Specifications

Parameter	Symbol	8-Pin DIP (300 Mil) Value	SO-8 Value	Widebody (400 Mil) Value	Units	Conditions
Minimum External Air Gap (External Clearance)	L(101)	7.1	4.9	9.6	mm	Measured from input terminals to output terminals, shortest distance through air.
Minimum External Tracking (External Creepage)	L(102)	7.4	4.8	10.0	mm	Measured from input terminals to output terminals, shortest distance path along body.
Minimum Internal Plastic Gap (Internal Clearance)		0.08	0.08	1.0	mm	Through insulation distance, conductor to conductor, usually the direct distance between the photoemitter and photodetector inside the optocoupler cavity.
Minimum Internal Tracking (Internal Creepage)		NA	NA	4.0	mm	Measured from input terminals to output terminals, along internal cavity.
Tracking Resistance (Comparative Tracking Index)	CTI	200	200	200	Volts	DIN IEC 112/VDE 0303 Part 1
Isolation Group		IIIa	IIIa	IIIa		Material Group (DIN VDE 0110, 1/89, Table 1)

Option 300 - surface mount classification is Class A in accordance with CECC 00802.

IEC/EN/DIN EN 60747-5-2 Insulation Related Characteristics (HCPL-4503 OPTION 060 ONLY)

Description	Symbol	Characteristic	Units
Installation classification per DIN VDE 0110/1.89, Table 1 for rated mains voltage ≤ 300 V rms for rated mains voltage ≤ 450 V rms		I-IV	
		I-III	
Climatic Classification		55/100/21	
Pollution Degree (DIN VDE 0110/1.89)		2	
Maximum Working Insulation Voltage	V_{IORM}	630	V _{peak}
Input to Output Test Voltage, Method b* $V_{IORM} \times 1.875 = V_{PR}$, 100% Production Test with $t_m = 1$ sec, Partial Discharge < 5 pC	V_{PR}	1181	V _{peak}
Input to Output Test Voltage, Method a* $V_{IORM} \times 1.5 = V_{PR}$, Type and sample test, $t_m = 60$ sec, Partial Discharge < 5 pC	V_{PR}	945	V _{peak}
Highest Allowable Overvoltage* (Transient Overvoltage, $t_{ini} = 10$ sec)	V_{IOTM}	6000	V _{peak}
Safety Limiting Values (Maximum values allowed in the event of a failure, also see Figure 9, Thermal Derating curve.)			
Case Temperature	T_S	175	°C
Input Current	$I_{S,INPUT}$	230	mA
Output Power	$P_{S,OUTPUT}$	600	mW
Insulation Resistance at T_S , $V_{IO} = 500$ V	R_S	$\geq 10^9$	Ω

IEC/EN/DIN EN 60747-5-2 Insulation Related Characteristics (HCNW135/6, HCNW4502/3 ONLY)

Description	Symbol	Characteristic	Units
Installation classification per DIN VDE 0110/1.89, Table 1 for rated mains voltage ≤ 600 V rms for rated mains voltage ≤ 1000 V rms		I-IV	
		I-III	
Climatic Classification		55/85/21	
Pollution Degree (DIN VDE 0110/1.89)		2	
Maximum Working Insulation Voltage	V_{IORM}	1414	V _{peak}
Input to Output Test Voltage, Method b* $V_{IORM} \times 1.875 = V_{PR}$, 100% Production Test with $t_m = 1$ sec, Partial Discharge < 5 pC	V_{PR}	2652	V _{peak}
Input to Output Test Voltage, Method a* $V_{IORM} \times 1.5 = V_{PR}$, Type and sample test, $t_m = 60$ sec, Partial Discharge < 5 pC	V_{PR}	2121	V _{peak}
Highest Allowable Overvoltage* (Transient Overvoltage, $t_{ini} = 10$ sec)	V_{IOTM}	8000	V _{peak}
Safety Limiting Values (Maximum values allowed in the event of a failure, also see Figure 9, Thermal Derating curve.)			
Case Temperature	T_S	150	°C
Input Current	$I_{S,INPUT}$	400	mA
Output Power	$P_{S,OUTPUT}$	700	mW
Insulation Resistance at T_S , $V_{IO} = 500$ V	R_S	$\geq 10^9$	Ω

*Refer to the front of the optocoupler section of the current catalog, under Product Safety Regulations section IEC/EN/DIN EN 60747-5-2, for a detailed description.

Note: Isolation characteristics are guaranteed only within the safety maximum ratings which must be ensured by protective circuits in application.

Absolute Maximum Ratings

Parameter	Symbol	Device	Min.	Max.	Units	Note
Storage Temperature*	T_S		-55	125	°C	
Operating Temperature*	T_A	8-Pin DIP SO-8	-55	100	°C	
		Widebody	-55	85		
Average Forward Input Current*	$I_{F(AVG)}$			25	mA	1
Peak Forward Input Current* (50% duty cycle, 1 ms pulse width) (50% duty cycle, 1 ms pulse width)	$I_{F(PEAK)}$	8-Pin DIP SO-8		50	mA	2
		Widebody		40		
Peak Transient Input Current* ($\leq 1 \mu s$ pulse width, 300 pps)	$I_{F(TRANS)}$	8-Pin DIP SO-8		1	A	
		Widebody		0.1		
Reverse LED Input Voltage* (Pin 3-2)	V_R	8-Pin DIP SO-8		5	V	
		Widebody		3		
Input Power Dissipation*	P_{IN}	8-Pin DIP SO-8		45	mW	3
		Widebody		40		
Average Output Current* (Pin 6)	$I_{O(AVG)}$			8	mA	
Peak Output Current*	$I_{O(PEAK)}$			16	mA	
Emitter-Base Reverse Voltage* (Pin 5-7, except 4502/3, 0452/3)	V_{EBR}			5	V	
Supply Voltage (Pin 8-5)	V_{CC}		-0.5	30	V	
Output Voltage (Pin 6-5)	V_O		-0.5	20	V	
Supply Voltage* (Pin 8-5)	V_{CC}		-0.5	15	V	
Output Voltage* (Pin 6-5)	V_O		-0.5	15	V	
Base Current* (Pin 7, except 4502/3, 0452/3)	I_B			5	mA	
Output Power Dissipation*	P_O			100	mW	4
Lead Solder Temperature* (Through-Hole Parts Only) 1.6 mm below seating plane, 10 seconds up to seating plane, 10 seconds	T_{LS}	8-Pin DIP		260	°C	
		Widebody		260	°C	
Reflow Temperature Profile	T_{RP}	SO-8 and Option 300	See Package Outline Drawings section			

*Data has been registered with JEDEC for the 6N135/6N136.

Electrical Specifications (DC)

Over recommended temperature ($T_A = 0^\circ\text{C}$ to 70°C) unless otherwise specified. See note 13.

Parameter	Symbol	Device	Min.	Typ.**	Max.	Units	Test Conditions			Fig.	Note
Current Transfer Ratio	CTR*	6N135	7	18	50	%	$T_A = 25^\circ\text{C}$	$V_O = 0.4\text{ V}$	$I_F = 16\text{ mA}$, $V_{CC} = 4.5\text{ V}$	1, 2, 4	5, 11
		HCPL-0500						$V_O = 0.5\text{ V}$			
		HCNW135	5	19							
		HCPL-2502	15		22		$T_A = 25^\circ\text{C}$	$V_O = 0.4\text{ V}$			
			15	25				$V_O = 0.5\text{ V}$			
		6N136	19	24	50		$T_A = 25^\circ\text{C}$	$V_O = 0.4\text{ V}$			
Logic Low Output Voltage	V_{OL}	6N135		0.1	0.4	V	$T_A = 25^\circ\text{C}$	$I_O = 1.1\text{ mA}$	$I_F = 16\text{ mA}$, $V_{CC} = 4.5\text{ V}$		
		HCPL-0500						$I_O = 0.8\text{ mA}$			
		HCNW135		0.1	0.5						
		6N136		0.1	0.4		$T_A = 25^\circ\text{C}$	$I_O = 3.0\text{ mA}$			
		HCPL-2502						$I_O = 2.4\text{ mA}$			
		HCPL-4502/3		0.1	0.5						
Logic High Output Current	I_{OH}^*			0.003	0.5	μA	$T_A = 25^\circ\text{C}$	$V_O = V_{CC} = 5.5\text{ V}$	$I_F = 0\text{ mA}$	7	
				0.01	1		$T_A = 25^\circ\text{C}$	$V_O = V_{CC} = 15\text{ V}$			
					50			$V_O = V_{CC} = 15\text{ V}$			
Logic Low Supply Current	I_{CCL}		50	200	μA	$I_F = 16\text{ mA}$, $V_O = \text{Open}$, $V_{CC} = 15\text{ V}$				13	
Logic High Supply Current	I_{CCH}^*			0.02	1	μA	$T_A = 25^\circ\text{C}$	$I_F = 16\text{ mA}$, $V_O = \text{Open}$, $V_{CC} = 15\text{ V}$		13	
					2						
Input Forward Voltage	V_F^*	8-Pin DIP		1.5	1.7	V	$T_A = 25^\circ\text{C}$	$I_F = 16\text{ mA}$	3		
		SO-8					1.8				
		Widebody									1.45
		1.35		1.95							
Input Reverse Breakdown Voltage	BV_R^*	8-Pin DIP	5			V	$I_R = 10\text{ }\mu\text{A}$				
		SO-8					$I_R = 100\text{ }\mu\text{A}$				
Temperature Coefficient of Forward Voltage	$\frac{\Delta V_F}{\Delta T_A}$	8-Pin DIP		-1.6		$\text{mV}/^\circ\text{C}$	$I_F = 16\text{ mA}$				
		SO-8									
		Widebody		-1.9							
Input Capacitance	C_{IN}	8-Pin DIP		60		pF	$f = 1\text{ MHz}$, $V_F = 0\text{ V}$				
		SO-8									
		Widebody		90							
Transistor DC Current Gain	h_{FE}	8-Pin DIP		150			$V_O = 5\text{ V}$, $I_O = 3\text{ mA}$				
				130			$V_O = 0.4\text{ V}$, $I_B = 20\text{ }\mu\text{A}$				
				180			$V_O = 5\text{ V}$, $I_O = 3\text{ mA}$				
				160			$V_O = 0.4\text{ V}$, $I_B = 20\text{ }\mu\text{A}$				

*For JEDEC registered parts.

**All typicals at $T_A = 25^\circ\text{C}$.

Switching Specifications (AC)

Over recommended temperature ($T_A = 0^\circ\text{C}$ to 70°C), $V_{CC} = 5\text{ V}$, $I_F = 16\text{ mA}$ unless otherwise specified.

Parameter	Sym.	Device	Min.	Typ.**	Max.	Units	Test Conditions	Fig.	Note
Propagation Delay Time to Logic Low at Output	t_{PHL}^*	6N135 HCPL-0500 HCNW135		0.2	1.5	μs	$T_A = 25^\circ\text{C}$ $R_L = 4.1\text{ k}\Omega$	5, 6, 11	8, 9
		6N136 HCPL-2502 HCPL-4502/3 HCPL-0501		0.2	0.8		$T_A = 25^\circ\text{C}$ $R_L = 1.9\text{ k}\Omega$		
		HCPL-0452/3 HCNW136 HCNW4502/3			1.0				
Propagation Delay Time to Logic High at Output	t_{PLH}^*	6N135 HCPL-0500 HCNW135		1.3	1.5	μs	$T_A = 25^\circ\text{C}$ $R_L = 4.1\text{ k}\Omega$	5, 6, 11	8, 9
		6N136 HCPL-2502 HCPL-4502/3 HCPL-0501		0.6	0.8		$T_A = 25^\circ\text{C}$ $R_L = 1.9\text{ k}\Omega$		
		HCPL-0452/3 HCNW136 HCNW4502/3			1.0				
Common Mode Transient Immunity at Logic High Level Output	$ CM_H $	6N135 HCPL-0500 HCNW135		1		$\text{kV}/\mu\text{s}$	$R_L = 4.1\text{ k}\Omega$ $I_F = 0\text{ mA}$, $T_A = 25^\circ\text{C}$, $V_{CM} = 10\text{ V}_{p-p}$ $C_L = 15\text{ pF}$	12	7, 8, 9
		6N136 HCPL-2502 HCPL-4502 HCPL-0501 HCPL-0452 HCNW4502		1			$R_L = 1.9\text{ k}\Omega$		
		HCPL-4503 HCPL-0453 HCNW4503	15	30			$R_L = 1.9\text{ k}\Omega$ $I_F = 0\text{ mA}$, $T_A = 25^\circ\text{C}$, $V_{CM} = 1500\text{ V}_{p-p}$, $C_L = 15\text{ pF}$		
Common Mode Transient Immunity at Logic Low Level Output	$ CM_L $	6N135 HCPL-0500 HCNW135		1		$\text{kV}/\mu\text{s}$	$R_L = 4.1\text{ k}\Omega$ $I_F = 16\text{ mA}$, $T_A = 25^\circ\text{C}$, $V_{CM} = 10\text{ V}_{p-p}$ $C_L = 15\text{ pF}$	12	7, 8, 9
		6N136 HCPL-2502 HCPL-4502 HCPL-0501 HCPL-0452 HCNW4502		1			$R_L = 1.9\text{ k}\Omega$		
		HCPL-4503 HCPL-0453 HCNW4503	15	30			$R_L = 1.9\text{ k}\Omega$ $I_F = 16\text{ mA}$, $T_A = 25^\circ\text{C}$, $V_{CM} = 1500\text{ V}_{p-p}$, $C_L = 15\text{ pF}$		
Bandwidth	BW	6N135/6 HCPL-2502 HCPL-0500/1		9		MHz	See Test Circuit	8, 10	10
		HCNW135/6		11					

*For JEDEC registered parts.

**All typicals at $T_A = 25^\circ\text{C}$.

Package Characteristics

Over recommended temperature ($T_A = 0^\circ\text{C}$ to 70°C) unless otherwise specified.

Parameter	Sym.	Device	Min.	Typ.*	Max.	Units	Test Conditions	Fig.	Note
Input-Output Momentary Withstand Voltage**	V_{ISO}	8-Pin DIP	3750			V rms	RH < 50%, $t = 1$ min., $T_A = 25^\circ\text{C}$		6, 14
		SO-8							6, 15
		Widebody	5000						
			8-Pin DIP (Option 020)	5000					6, 12, 15
	$I_{\text{I-O}}$	8-Pin DIP			1	μA	45% RH, $t = 5$ s, $V_{\text{I-O}} = 3$ kVdc, $T_A = 25^\circ\text{C}$		6, 16
Input-Output Resistance	$R_{\text{I-O}}$	8-Pin DIP		10^{12}		Ω	$V_{\text{I-O}} = 500$ Vdc $T_A = 25^\circ\text{C}$ $T_A = 100^\circ\text{C}$		6
		SO-8							
		Widebody	10^{12} 10^{11}	10^{13}					
Input-Output Capacitance	$C_{\text{I-O}}$	8-Pin DIP		0.6		pF	$f = 1$ MHz		6
		SO-8							
		Widebody		0.5	0.6				

*All typicals at $T_A = 25^\circ\text{C}$.

**The Input-Output Momentary Withstand Voltage is a dielectric voltage rating that should not be interpreted as an input-output continuous voltage rating. For the continuous voltage rating refer to the IEC/EN/DIN EN 60747-5-2 Insulation Related Characteristics Table (if applicable), your equipment level safety specification or Agilent Application Note 1074 entitled "Optocoupler Input-Output Endurance Voltage," publication number 5963-2203E.

Notes:

- Derate linearly above 70°C free-air temperature at a rate of 0.8 mA/ $^\circ\text{C}$ (8-Pin DIP).
Derate linearly above 85°C free-air temperature at a rate of 0.5 mA/ $^\circ\text{C}$ (SO-8).
- Derate linearly above 70°C free-air temperature at a rate of 1.6 mA/ $^\circ\text{C}$ (8-Pin DIP).
Derate linearly above 85°C free-air temperature at a rate of 1.0 mA/ $^\circ\text{C}$ (SO-8).
- Derate linearly above 70°C free-air temperature at a rate of 0.9 mW/ $^\circ\text{C}$ (8-Pin DIP).
Derate linearly above 85°C free-air temperature at a rate of 1.1 mW/ $^\circ\text{C}$ (SO-8).
- Derate linearly above 70°C free-air temperature at a rate of 2.0 mW/ $^\circ\text{C}$ (8-Pin DIP).
Derate linearly above 85°C free-air temperature at a rate of 2.3 mW/ $^\circ\text{C}$ (SO-8).
- CURRENT TRANSFER RATIO in percent is defined as the ratio of output collector current, I_O , to the forward LED input current, I_F , times 100.
- Device considered a two-terminal device: Pins 1, 2, 3, and 4 shorted together and Pins 5, 6, 7, and 8 shorted together.
- Common mode transient immunity in a Logic High level is the maximum tolerable (positive) dV_{CM}/dt on the leading edge of the common mode pulse signal, V_{CM} , to assure that the output will remain in a Logic High state (i.e., $V_O > 2.0$ V). Common mode transient immunity in a Logic Low level is the maximum tolerable (negative) dV_{CM}/dt on the trailing edge of the common mode pulse signal, V_{CM} , to assure that the output will remain in a Logic Low state (i.e., $V_O < 0.8$ V).
- The 1.9 k Ω load represents 1 TTL unit load of 1.6 mA and the 5.6 k Ω pull-up resistor.
- The 4.1 k Ω load represents 1 LSTTL unit load of 0.36 mA and 6.1 k Ω pull-up resistor.
- The frequency at which the ac output voltage is 3 dB below its mid-frequency value.
- The JEDEC registration for the 6N136 specifies a minimum CTR of 15%. Agilent guarantees a minimum CTR of 19%.
- See Option 020 data sheet for more information.
- Use of a 0.1 μF bypass capacitor connected between pins 5 and 8 is recommended.
- In accordance with UL 1577, each optocoupler is proof tested by applying an insulation test voltage ≥ 4500 V rms for 1 second (leakage detection current limit, $I_{\text{I-O}} \leq 5$ μA). This test is performed before the 100% Production test shown in the IEC/EN/DIN EN 60747-5-2 Insulation Related Characteristics Table if applicable.
- In accordance with UL 1577, each optocoupler is proof tested by applying an insulation test voltage ≥ 6000 V rms for 1 second (leakage detection current limit, $I_{\text{I-O}} \leq 5$ μA). This test is performed before the 100% Production test shown in the IEC/EN/DIN EN 60747-5-2 Insulation Related Characteristics Table if applicable.
- This rating is equally validated by an equivalent ac proof test.

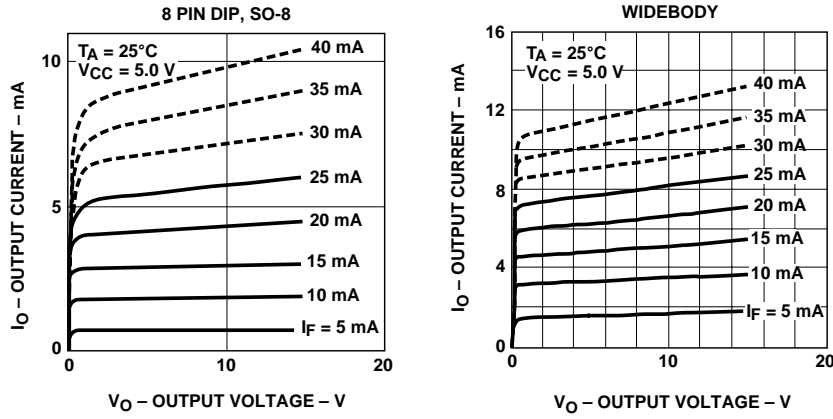

Figure 1. DC and Pulsed Transfer Characteristics.

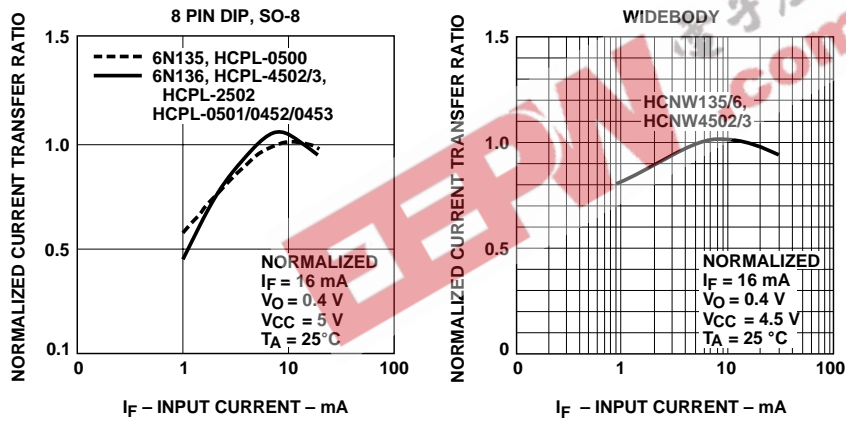

Figure 2. Current Transfer Ratio vs. Input Current.

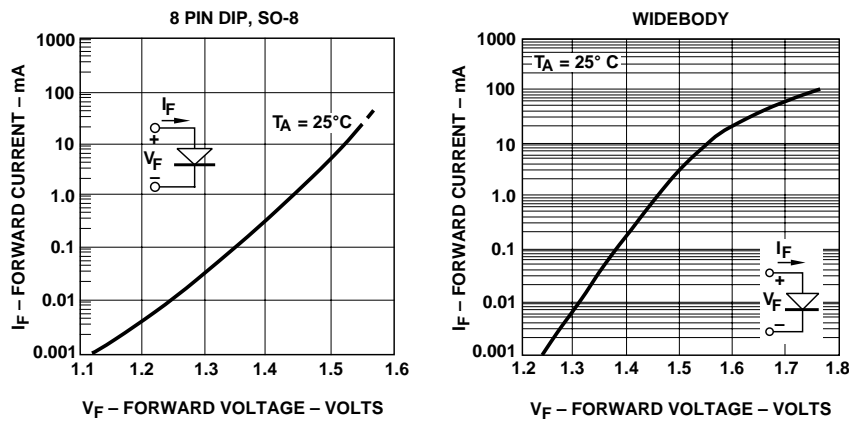

Figure 3. Input Current vs. Forward Voltage.

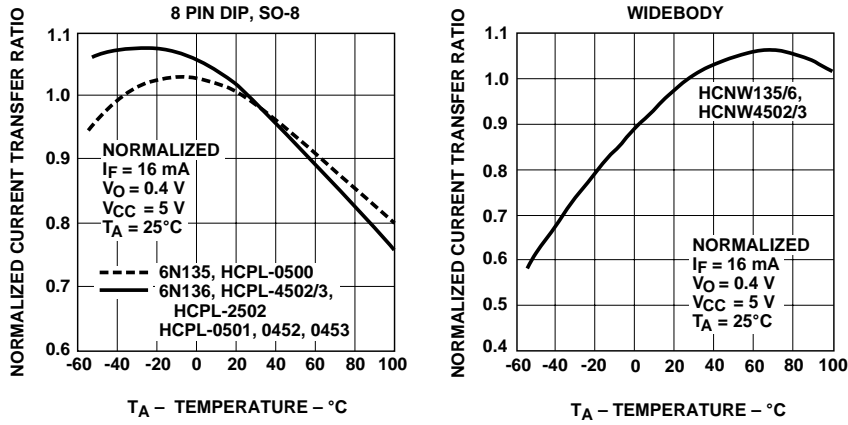

Figure 4. Current Transfer Ratio vs. Temperature.

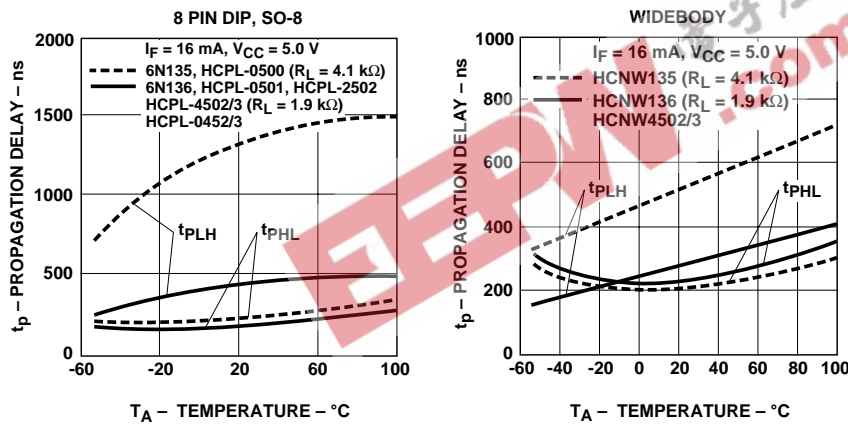

Figure 5. Propagation Delay vs. Temperature.

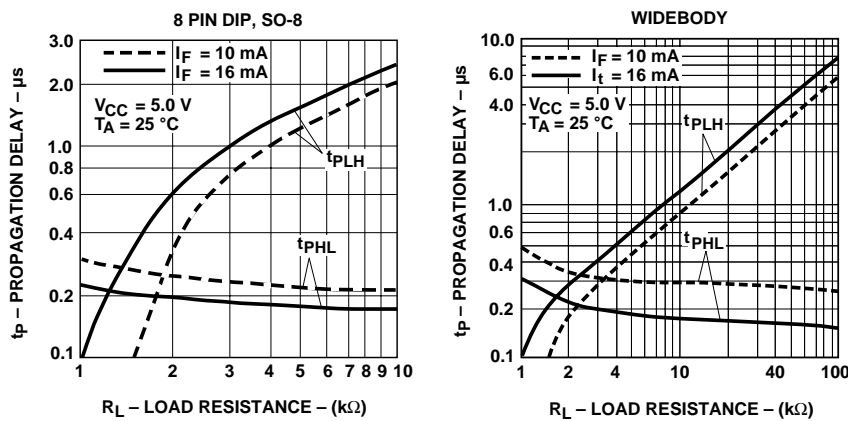

Figure 6. Propagation Delay Time vs. Load Resistance.

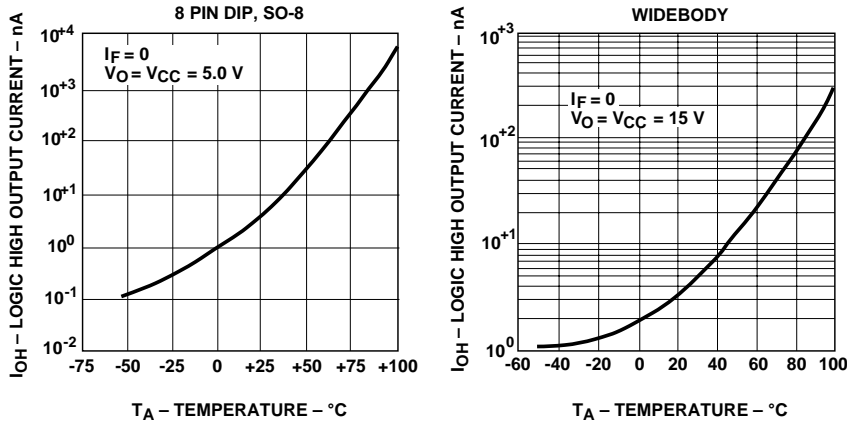

Figure 7. Logic High Output Current vs. Temperature.

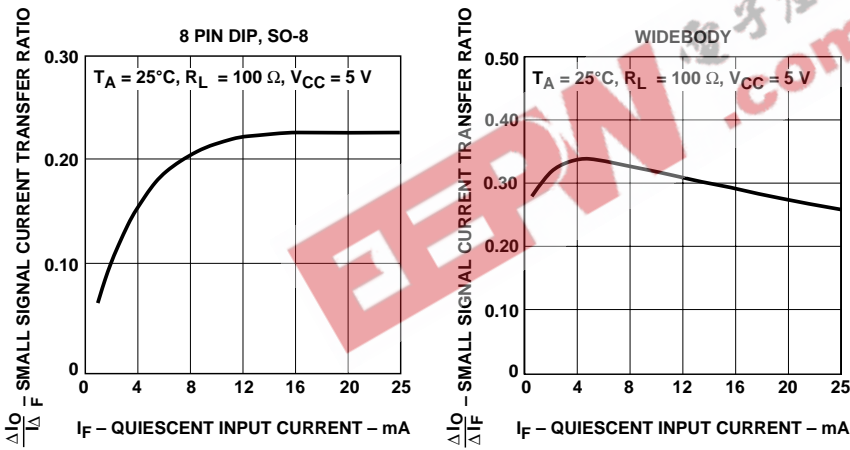

Figure 8. Small-Signal Current Transfer Ratio vs. Quiescent Input Current.

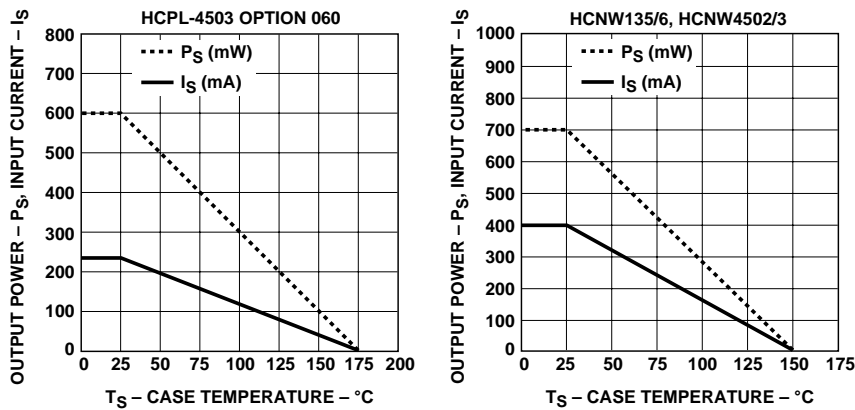

Figure 9. Thermal Derating Curve, Dependence of Safety Limiting Value with Case Temperature per IEC/EN/DIN EN 60747-5-2.

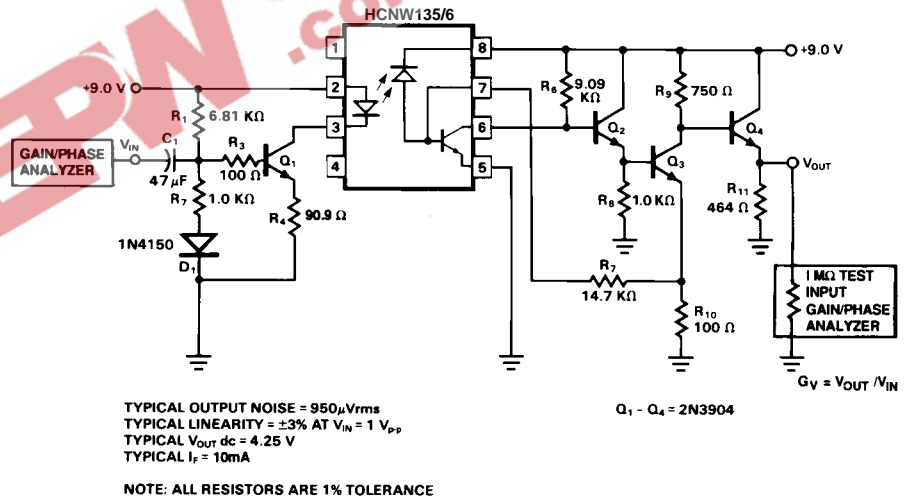
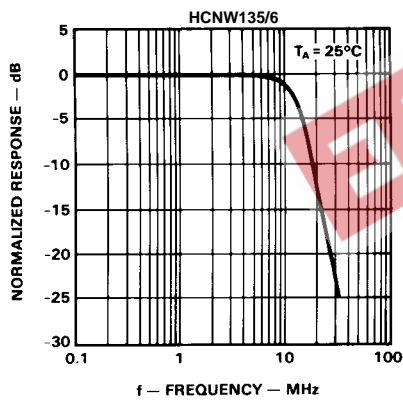
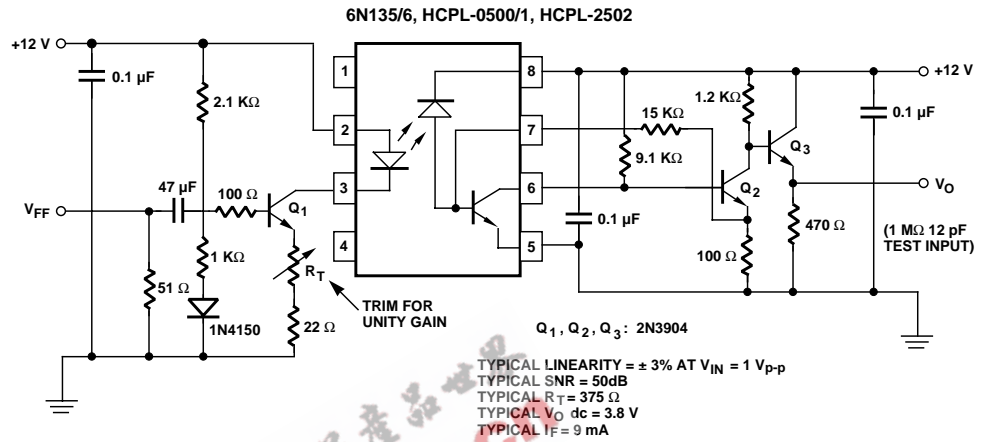
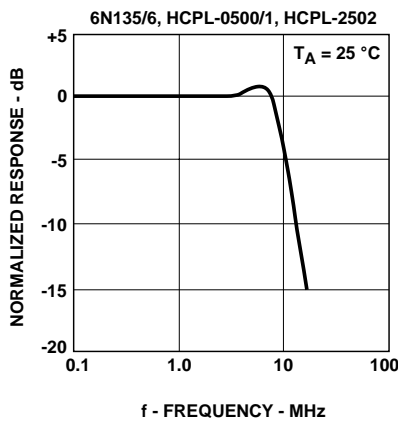

Figure 10. Frequency Response.

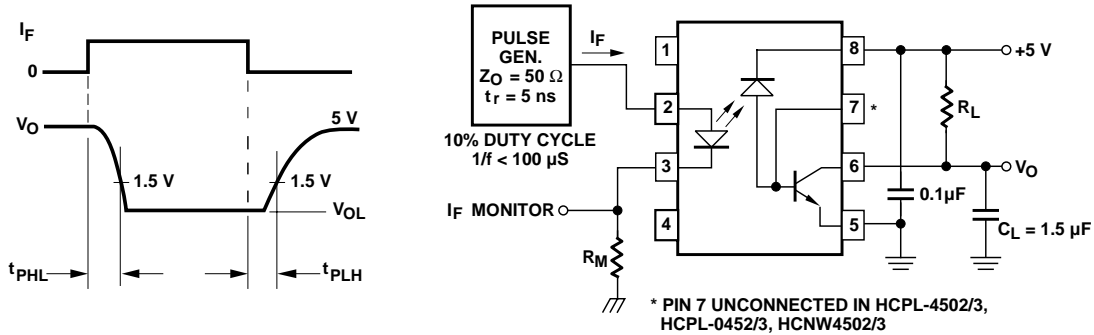

Figure 11. Switching Test Circuit.

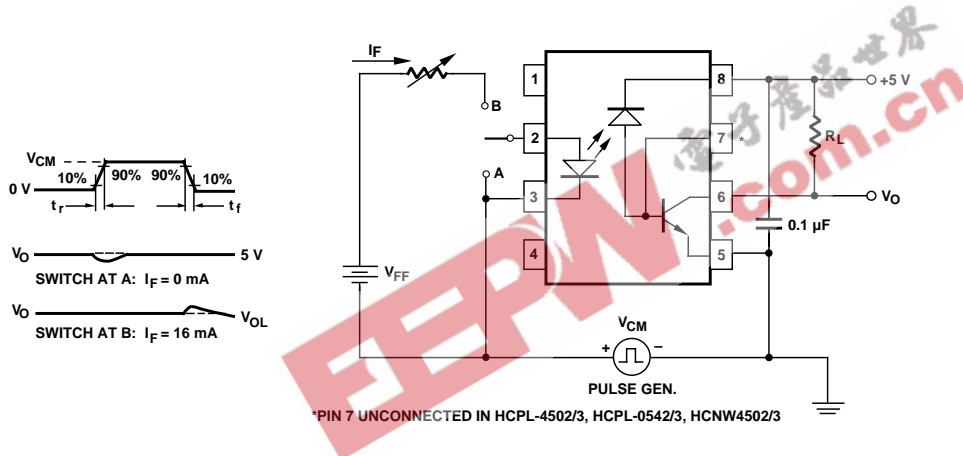

Figure 12. Test Circuit for Transient Immunity and Typical Waveforms.

www.agilent.com/semiconductors

For product information and a complete list of distributors, please go to our web site.

For technical assistance call:

Americas/Canada: +1 (800) 235-0312 or (916) 788-6763

Europe: +49 (0) 6441 92460

China: 10800 650 0017

Hong Kong: (+65) 6756 2394

India, Australia, New Zealand: (+65) 6755 1939

Japan: (+81 3) 3335-8152 (Domestic/International), or 0120-61-1280 (Domestic Only)

Korea: (+65) 6755 1989

Singapore, Malaysia, Vietnam, Thailand, Philippines, Indonesia: (+65) 6755 2044

Taiwan: (+65) 6755 1843

Data subject to change.

Copyright © 2004 Agilent Technologies, Inc.

Obsoletes 5989-0305EN

December 20, 2004

5989-2112EN