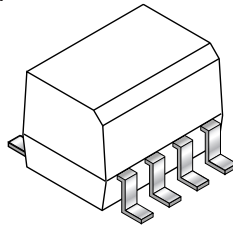


**DESCRIPTION**

The HCPL-0500, HCPL-0501 and HCPL-0452 optocouplers consist of an AlGaAs LED optically coupled to a high speed photodetector transistor housed in a compact 8-pin smalloutline package.

A separate connection for the bias of the photodiode improves the speed by several orders of magnitude over conventional phototransistor optocouplers by reducing the base-collector capacitance of the input transistor.

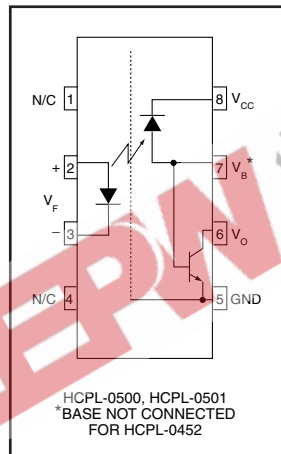


**FEATURES**

- High speed-1 MBit/s
- Superior CMR-1 kV/μs
- CTR guaranteed 0-70°C
- U.L. recognized (File # E90700)

**APPLICATIONS**

- Line receivers
- Pulse transformer replacement
- Output interface to CMOS-LSTTL-TTL
- Wide bandwidth analog coupling

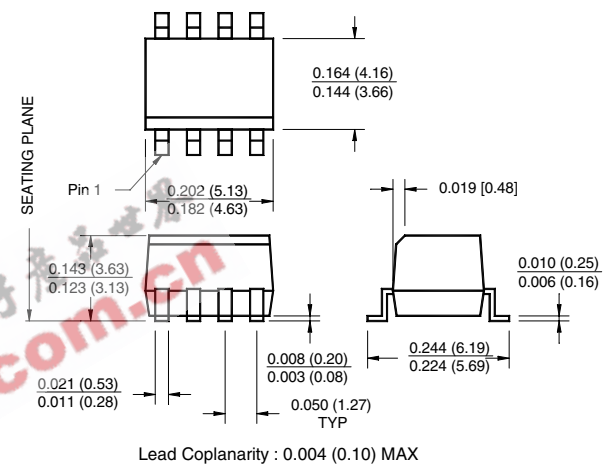


**SINGLE-CHANNEL**

**HCPL-0500  
HCPL-0501**

**HCPL-0452**

**Package Dimensions**



**NOTE**

All dimensions are in inches (millimeters)

**ABSOLUTE MAXIMUM RATINGS** ( $T_A = 25^\circ\text{C}$  unless otherwise specified)

Parameter	Symbol	Value	Units
Storage Temperature	$T_{STG}$	-55 to +125	°C
Operating Temperature	$T_{OPR}$	-55 to +100	°C
Reflow Temperature Profile (Refer to fig. 11)			
<b>EMITTER</b>			
DC/Average Forward Input Current	$I_F$ (avg)	25	mA
Peak Forward Input Current (50% duty cycle, 1 ms P.W.)	$I_F$ (pk)	50	mA
Peak Transient Input Current - ( $\leq 1 \mu\text{s}$ P.W., 300 pps)	$I_F$ (trans)	1.0	A
Reverse Input Voltage	$V_R$	5	V
Input Power Dissipation	$P_D$	45	mW
<b>DETECTOR</b>			
Average Output Current (Pin 6)	$I_O$ (avg)	8	mA
Peak Output Current	$I_O$ (pk)	16	mA
Emitter-Base Reverse Voltage (Except HCPL-0452)	$V_{EBR}$	5	V
Supply Voltage	$V_{CC}$	-0.5 to 30	V
Output Voltage	$V_O$	-0.5 to 20	V
Base Current (Except HCPL-0452)	$I_B$	5	mA
Output power dissipation	$P_D$	100	mW

**SINGLE-CHANNEL**  
**HCPL-0500**                      **HCPL-0452**  
**HCPL-0501**

**ELECTRICAL CHARACTERISTICS** ( $T_A = 0$  to  $70^\circ\text{C}$  Unless otherwise specified)

**INDIVIDUAL COMPONENT CHARACTERISTICS**

Parameter	Test Conditions	Symbol	Device	Min	Typ**	Max	Unit
<b>EMITTER</b>							
Input Forward Voltage	( $I_F = 16$ mA, $T_A = 25^\circ\text{C}$ )	$V_F$	All		1.45	1.7	V
	( $I_F = 16$ mA)					1.8	
Input Reverse Breakdown Voltage	( $I_R = 10$ $\mu\text{A}$ )	$BV_R$	All	5.0			V
Temperature coefficient of forward voltage	( $I_F = 16$ mA)	$(\Delta V_F / \Delta T_A)$	All		-1.6		mV/ $^\circ\text{C}$
<b>DETECTOR</b>							
Logic high output current	( $I_F = 0$ mA, $V_O = V_{CC} = 5.5$ V)	$I_{OH}$	All		0.001	0.5	$\mu\text{A}$
	( $T_A = 25^\circ\text{C}$ )						
	( $I_F = 0$ mA, $V_O = V_{CC} = 15$ V)		All		0.005	1	
	( $T_A = 25^\circ\text{C}$ )		All			50	
Logic low supply current	( $I_F = 16$ mA, $V_O = \text{Open}$ )	$I_{CCL}$	All		120	200	$\mu\text{A}$
	( $V_{CC} = 15$ V)						
Logic high supply current	( $I_F = 0$ mA, $V_O = \text{Open}$ , $V_{CC} = 15$ V)	$I_{CCH}$	All		0.01	1	$\mu\text{A}$
	( $T_A = 25^\circ\text{C}$ )						
	( $I_F = 0$ mA, $V_O = \text{Open}$ )		All				
	( $V_{CC} = 15$ V)						

**TRANSFER CHARACTERISTICS** ( $T_A = 0$  to  $70^\circ\text{C}$  Unless otherwise specified)

Parameter	Test Conditions	Symbol	Device	Min	Typ**	Max	Unit
<b>COUPLED</b>							
Current transfer ratio (Note 5)	( $I_F = 16$ mA, $V_O = 0.4$ V ) ( $V_{CC} = 4.5$ V, $T_A = 25^\circ\text{C}$ )	CTR	HCPL-0500	7	27	50	%
			HCPL-0452	19	27	50	
			HCPL-0501				
	( $I_F = 16$ mA, $V_O = 0.5$ V ) ( $V_{CC} = 4.5$ V )		HCPL-0500	5	30		
			HCPL-0452	15	30		
			HCPL-0501				
Logic low output voltage output voltage	( $I_F = 16$ mA, $I_O = 1.1$ mA ) ( $V_{CC} = 4.5$ V, $T_A = 25^\circ\text{C}$ )	$V_{OL}$	HCPL-0500		0.18	0.4	V
	( $I_F = 16$ mA, $I_O = 3$ mA ) ( $V_{CC} = 4.5$ V, $T_A = 25^\circ\text{C}$ )		HCPL-0452		0.25	0.4	
			HCPL-0501				
	( $I_F = 16$ mA, $I_O = 0.8$ mA ) ( $V_{CC} = 4.5$ V )		HCPL-0500		0.13	0.5	
	( $I_F = 16$ mA, $I_O = 2.4$ mA ) ( $V_{CC} = 4.5$ V )		HCPL-0452		0.23	0.5	
			HCPL-0501				

\*\* All typicals at  $T_A = 25^\circ\text{C}$

**SINGLE-CHANNEL  
HCPL-0500                      HCPL-0452  
HCPL-0501**

**SWITCHING CHARACTERISTICS** ( $T_A = 0$  to  $70^\circ\text{C}$  unless otherwise specified.,  $V_{CC} = 5\text{ V}$ )

Parameter	Test Conditions	Symbol	Device	Min	Typ**	Max	Unit
Propagation delay time to logic low	$T_A = 25^\circ\text{C}$ , ( $R_L = 4.1\text{ k}\Omega$ , $I_F = 16\text{ mA}$ ) (Note 6) (Fig. 9) $T_A = 25^\circ\text{C}$ ( $R_L = 1.9\text{ k}\Omega$ , $I_F = 16\text{ mA}$ ) (Note 7) (Fig. 9) ( $R_L = 4.1\text{ k}\Omega$ , $I_F = 16\text{ mA}$ ) (Note 6) (Fig. 9) ( $R_L = 1.9\text{ k}\Omega$ , $I_F = 16\text{ mA}$ ) (Note 7) (Fig. 9)	$T_{PHL}$	HCPL-0500		0.45	1.5	$\mu\text{s}$
			HCPL-0452		0.45	0.8	
			HCPL-0501				
			HCPL-0500			2.0	
			HCPL-0452				
			HCPL-0501			1.0	
Propagation delay time to logic high	$T_A = 25^\circ\text{C}$ , ( $R_L = 4.1\text{ k}\Omega$ , $I_F = 16\text{ mA}$ ) (Note 6) (Fig. 9) $T_A = 25^\circ\text{C}$ ( $R_L = 1.9\text{ k}\Omega$ , $I_F = 16\text{ mA}$ ) (Note 7) (Fig. 9) ( $R_L = 4.1\text{ k}\Omega$ , $I_F = 16\text{ mA}$ ) (Note 6) (Fig. 9) ( $R_L = 1.9\text{ k}\Omega$ , $I_F = 16\text{ mA}$ ) (Note 7) (Fig. 9)	$T_{PLH}$	HCPL-0500		0.5	1.5	$\mu\text{s}$
			HCPL-0452		0.3	0.8	
			HCPL-0501				
			HCPL-0500			2.0	
			HCPL-0452				
			HCPL-0501			1.0	
Common mode transient immunity at logic high	$(I_F = 0\text{ mA}, V_{CM} = 10\text{ V}_{P-P}, R_L = 4.1\text{ k}\Omega)$ (Note 8) (Fig. 10) $T_A = 25^\circ\text{C}$ $T_A = 25^\circ\text{C}$ , ( $R_L = 1.9\text{ k}\Omega$ ) (Note 8) (Fig. 10)	$ICM_{HI}$	HCPL-0500		1,000		$\text{V}/\mu\text{s}$
			HCPL-0452		1,000		
			HCPL-0501				
Common mode transient immunity at logic low	$(I_F = 16\text{ mA}, V_{CM} = 10\text{ V}_{P-P}, R_L = 4.1\text{ k}\Omega)$ (Note 8) (Fig. 10) $T_A = 25^\circ\text{C}$ $(I_F = 16\text{ mA}, V_{CM} = 10\text{ V}_{P-P})$ ( $R_L = 1.9\text{ k}\Omega$ ) (Note 8) (Fig. 10)	$ICM_{LI}$	HCPL-0500		1,000		$\text{V}/\mu\text{s}$
			HCPL-0452		1,000		
			HCPL-0501				

**ISOLATION CHARACTERISTICS** ( $T_A = 0^\circ\text{C}$  to  $+70^\circ\text{C}$  Unless otherwise specified.)

Characteristics	Test Conditions	Symbol	Min	Typ**	Max	Unit
Input-Output Isolation Voltage	( $f = 60\text{ Hz}$ , $t = 1.0\text{ min}$ ) <sup>(9,10)</sup>	$V_{ISO}$	2500	—	—	$\text{Vac}_{RMS}$
Isolation Resistance	( $V_{I-O} = 500\text{ V}$ ) <sup>(9)</sup>	$R_{ISO}$	$10^{11}$	—	—	$\Omega$
Isolation Capacitance	( $V_{I-O} = 0$ , $f = 1.0\text{ MHz}$ ) <sup>(9)</sup>	$C_{ISO}$	—	0.2	—	$\text{pF}$

\*\* All typicals at  $T_A = 25^\circ\text{C}$

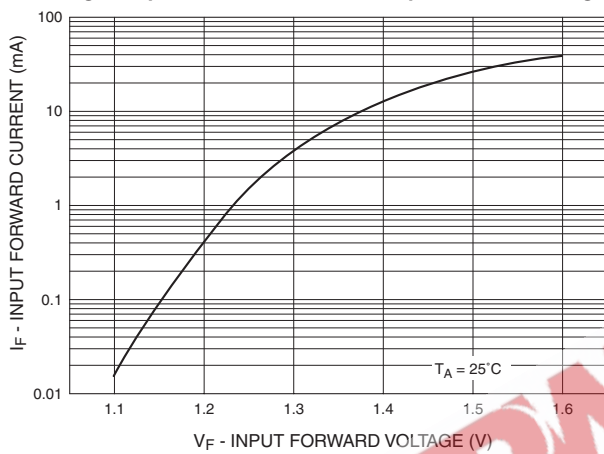
<b>SINGLE-CHANNEL</b>	
<b>HCPL-0500</b>	<b>HCPL-0452</b>
<b>HCPL-0501</b>	

**NOTES**

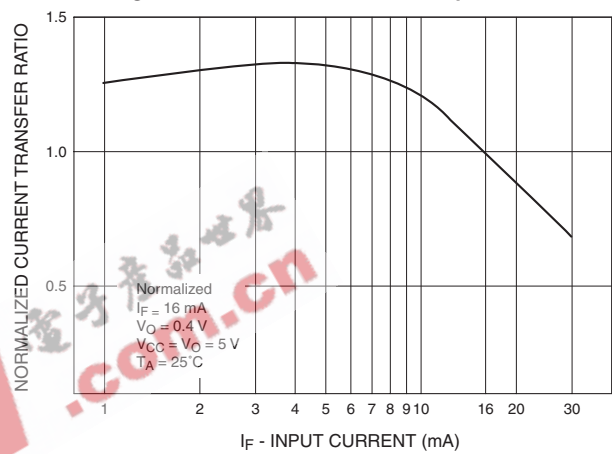
1. Derate linearly above 70°C free-air temperature at a rate of 0.8 mA/°C.
2. Derate linearly above 70°C free-air temperature at a rate of 1.6 mA/°C.
3. Derate linearly above 70°C free-air temperature at a rate of 0.9 mW/°C.
4. Derate linearly above 70°C free-air temperature at a rate of 2.0 mW/°C.
5. Current Transfer Ratio is defined as a ratio of output collector current,  $I_O$ , to the forward LED input current,  $I_F$ , times 100%.
6. The 4.1 kΩ load represents 1 LSTTL unit load of 0.36 mA and 6.1kΩ pull-up resistor.
7. The 1.9 kΩ load represents 1 TTL unit load of 1.6 mA and 5.6 kΩ pull-up resistor.
8. Common mode transient immunity in logic high level is the maximum tolerable (positive)  $dV_{CM}/dt$  on the leading edge of the common mode pulse signal  $V_{CM}$ , to assure that the output will remain in a logic high state (i.e.,  $V_O > 2.0$  V). Common mode transient immunity in logic low level is the maximum tolerable (negative)  $dV_{CM}/dt$  on the trailing edge of the common mode pulse signal,  $V_{CM}$ , to assure that the output will remain in a logic low state (i.e.,  $V_O < 0.8$  V).
9. Device is considered a two terminal device: Pins 1, 2, 3 and 4 are shorted together and Pins 5, 6, 7 and 8 are shorted together.
10. 2500 VAC RMS for 1 minute duration is equivalent to 3000 VAC RMS for 1 second duration.

**SINGLE-CHANNEL**  
**HCPL-0500                      HCPL-0452**  
**HCPL-0501**

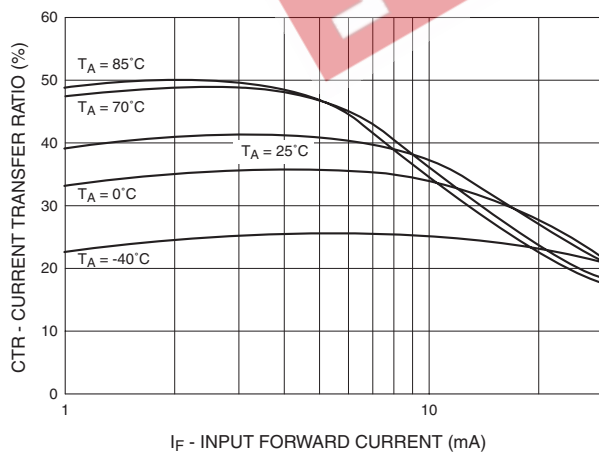
**Fig. 1 Input Forward Current vs. Input Forward Voltage**



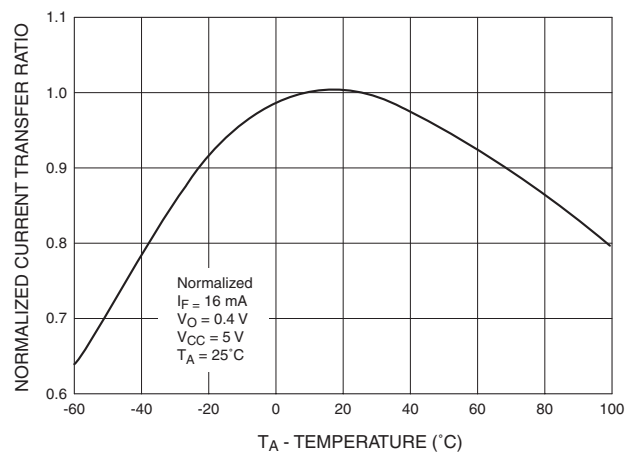
**Fig. 2 Current Transfer Ratio vs. Input Current**



**Fig. 3 Current Transfer Ratio vs. Input Forward Current**

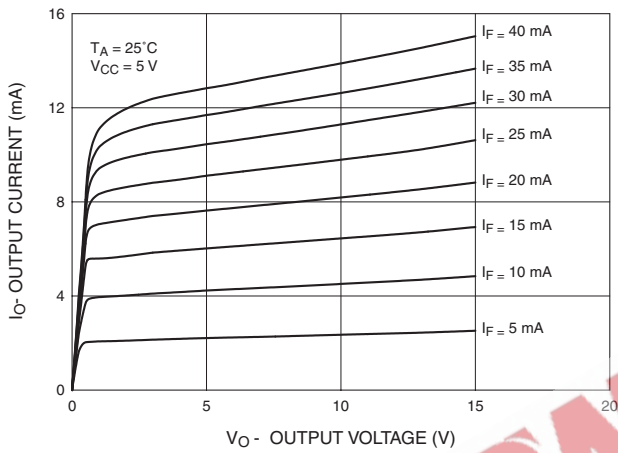


**Fig. 4 Current Transfer Ratio vs. Temperature**

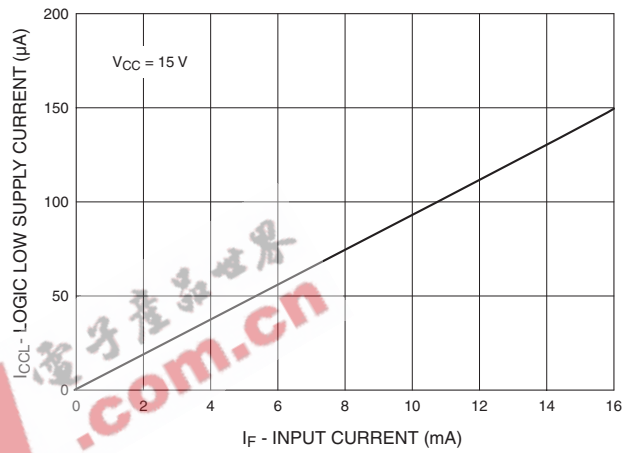


**SINGLE-CHANNEL**  
**HCPL-0500**                      **HCPL-0452**  
**HCPL-0501**

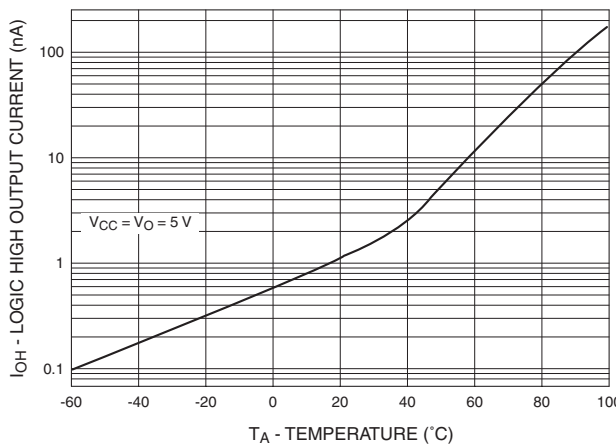
**Fig. 5 DC Transfer Characteristics**



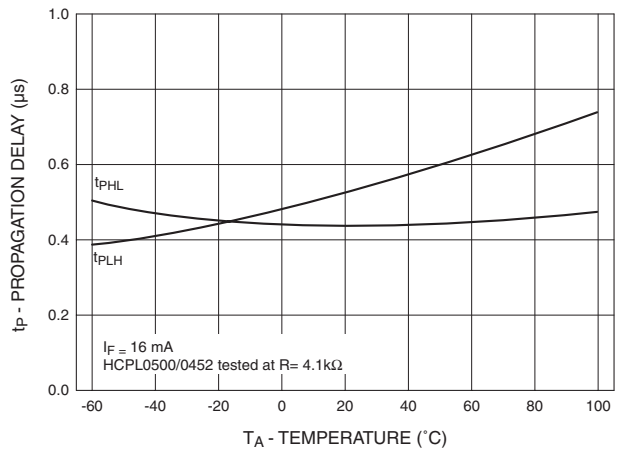
**Fig. 6 Logic Low Supply Current vs. Input Current**



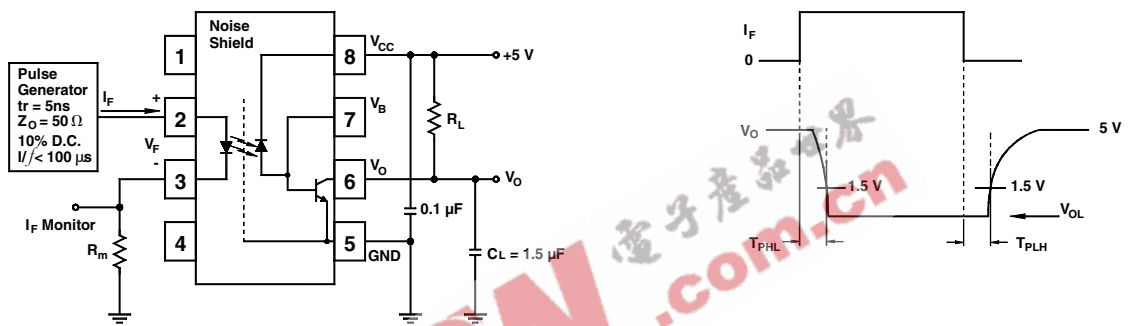
**Fig. 7 Logic High Output Current vs. Temperature**



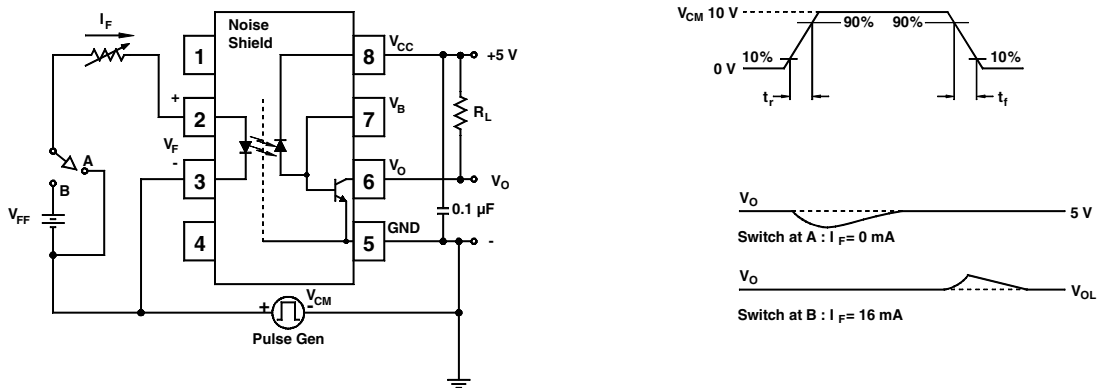
**Fig. 8 Propagation Delay vs. Temperature**



**SINGLE-CHANNEL  
HCPL-0500                      HCPL-0452  
HCPL-0501**



**Fig. 9 Switching Time Test Circuit**



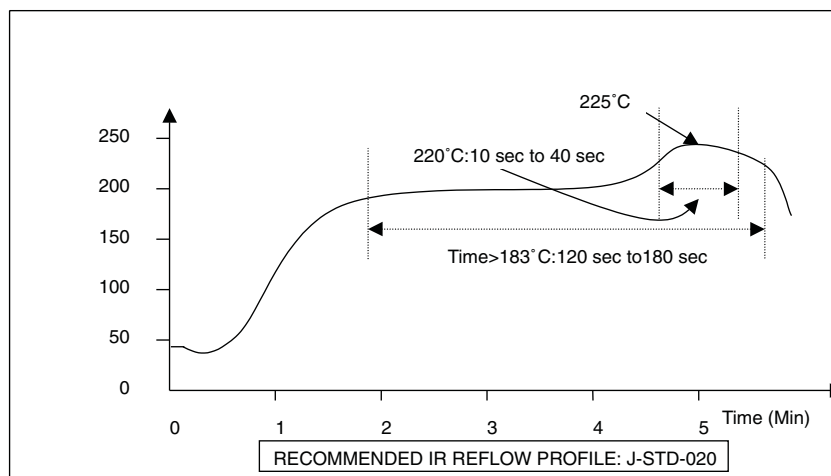
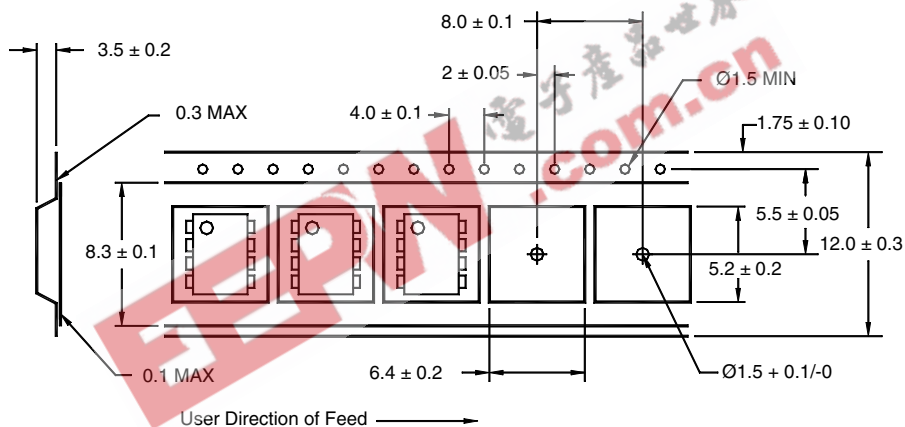
**Fig. 10 Common Mode Immunity Test Circuit**

**SINGLE-CHANNEL**  
**HCPL-0500**                      **HCPL-0452**  
**HCPL-0501**

**ORDERING INFORMATION**

Option	Order Entry Identifier	Description
R1	.R1	Tape and Reel (500 per reel)
R2	.R2	Tape and Reel (2500 per reel)

**QT Carrier Tape Specifications**



**Fig. 11 JEDEC Reflow Profile**



<b>SINGLE-CHANNEL</b>	
<b>HCPL-0500</b>	<b>HCPL-0452</b>
<b>HCPL-0501</b>	

**DISCLAIMER**

FAIRCHILD SEMICONDUCTOR RESERVES THE RIGHT TO MAKE CHANGES WITHOUT FURTHER NOTICE TO ANY PRODUCTS HEREIN TO IMPROVE RELIABILITY, FUNCTION OR DESIGN. FAIRCHILD DOES NOT ASSUME ANY LIABILITY ARISING OUT OF THE APPLICATION OR USE OF ANY PRODUCT OR CIRCUIT DESCRIBED HEREIN; NEITHER DOES IT CONVEY ANY LICENSE UNDER ITS PATENT RIGHTS, NOR THE RIGHTS OF OTHERS.

**LIFE SUPPORT POLICY**

FAIRCHILD'S PRODUCTS ARE NOT AUTHORIZED FOR USE AS CRITICAL COMPONENTS IN LIFE SUPPORT DEVICES OR SYSTEMS WITHOUT THE EXPRESS WRITTEN APPROVAL OF THE PRESIDENT OF FAIRCHILD SEMICONDUCTOR CORPORATION. As used herein:

1. Life support devices or systems are devices or systems which, (a) are intended for surgical implant into the body, or (b) support or sustain life, and (c) whose failure to perform when properly used in accordance with instructions for use provided in labeling, can be reasonably expected to result in a significant injury of the user.
2. A critical component in any component of a life support device or system whose failure to perform can be reasonably expected to cause the failure of the life support device or system, or to affect its safety or effectiveness.

This datasheet has been download from:

[www.datasheetcatalog.com](http://www.datasheetcatalog.com)

Datasheets for electronics components.

EEPW 电子產品世界  
.com.cn