



HER301G THRU HER308G

HIGH EFFICIENCY GLASS PASSIVATED RECTIFIER
Reverse Voltage - 50 to 1000 Volts
Forward Current - 3.0 Amperes

Features

- Low power loss, high efficiency
- Low leakage
- Low forward voltage drop
- High current capability
- High speed switching
- High reliability
- High current surge

DO-201AD



Mechanical Data

- **Case:** Molded plastic
- **Epoxy:** UL94V-0 rate flame retardant
- **Lead:** MIL-STD-202E method 208C guaranteed
- **Mounting Position:** Any
- **Weight:** 0.042 ounce, 1.195 grams

DIM	DIMENSIONS				Note
	inches		mm		
	Min.	Max.	Min.	Max.	
A	0.283	0.374	7.20	9.50	
B	0.189	0.208	4.80	5.30	φ
C	0.048	0.051	1.20	1.30	φ
D	1.000	-	25.40	-	

Maximum Ratings and Electrical Characteristics

Ratings at 25°C ambient temperature unless otherwise specified.
 Single phase, half wave, 60Hz, resistive or inductive load.
 For capacitive load, derate current by 20%.

	Symbols	HER 301G	HER 302G	HER 303G	HER 304G	HER 305G	HER 306G	HER 307G	HER 308G	Units
Maximum repetitive peak reverse voltage	V_{RRM}	50	100	200	300	400	600	800	1000	Volts
Maximum RMS voltage	V_{RMS}	35	70	140	210	280	420	560	700	Volts
Maximum DC blocking voltage	V_{DC}	50	100	200	300	400	600	800	1000	Volts
Maximum average forward rectified current 0.375" (9.5mm) lead length at $T_A=50^\circ\text{C}$	$I_{(AV)}$	3.0								Amps
Peak forward surge current, 8.3mS single half sine-wave superimposed on rated load (MIL-STD-750D 4066 method)	I_{FSM}	200.0				150.0				Amps
Maximum instantaneous forward voltage at 3.0A DC	V_F	1.0		1.3		1.5		1.7		Volts
Maximum full load reverse current average, full cycle 0.375" (9.5mm) lead length at $T_L=55^\circ\text{C}$	$I_{R(AV)}$	150.0								μA
Maximum DC reverse current at rated DC blocking voltage $T_A=25^\circ\text{C}$	I_R	10.0								μA
Maximum reverse recovery time (Note 1)	T_{rr}	50.0				75.0				nS
Typical junction capacitance (Note 2)	C_j	70				50				μF
Operating and storage temperature range	T_J, T_{STG}	-65 to +150								°C

Notes:

- (1) Test conditions: $I_p=0.5A$, $I_r=1.0A$, $I_{rr}=0.25A$
- (2) Measured at 1.0MHz and applied reverse voltage of 4.0 volts

RATINGS AND CHARACTERISTIC CURVES

FIG. 1 - TEST CIRCUIT DIAGRAM AND REVERSE RECOVERY TIME CHARACTERISTIC

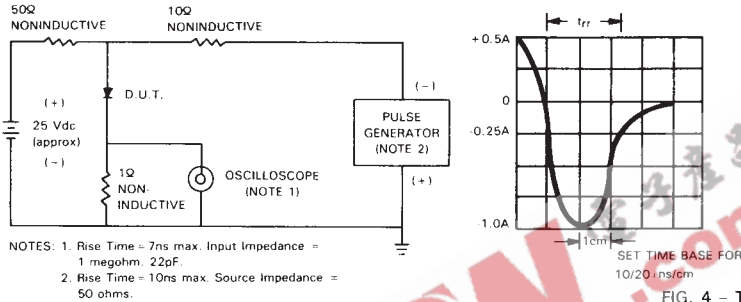

FIG. 2 - TYPICAL FORWARD CURRENT DERATING CURVE

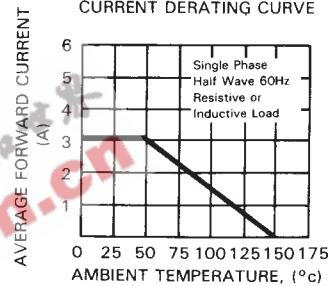

FIG. 3 - TYPICAL REVERSE CHARACTERISTICS

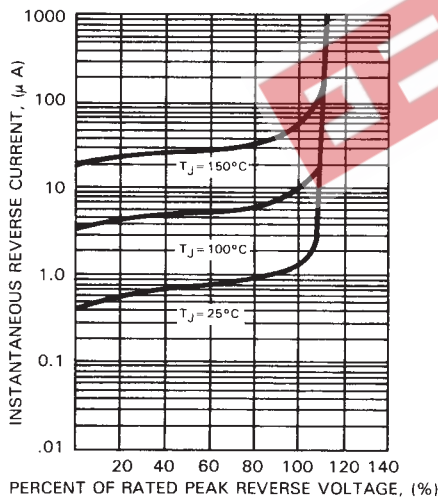

FIG. 4 - TYPICAL INSTANTANEOUS FORWARD CHARACTERISTICS

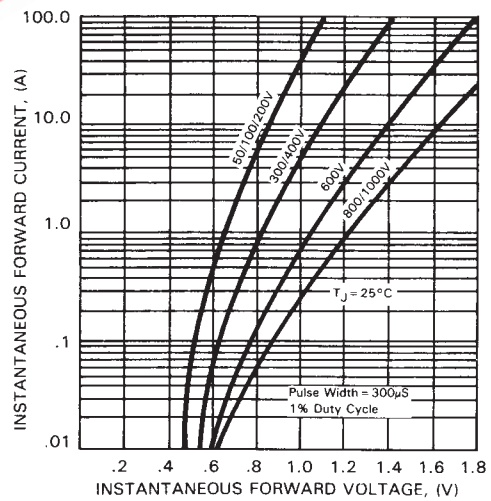

FIG. 5 - MAXIMUM NON-REPETITIVE FORWARD SURGE CURRENT

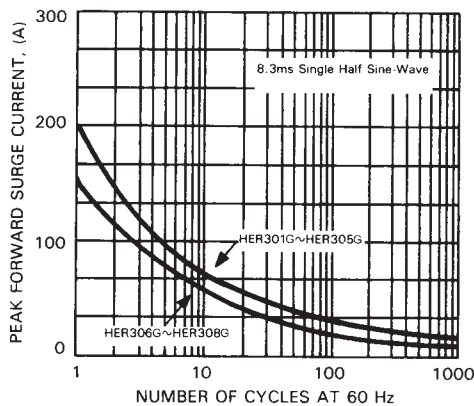

FIG. 6 - TYPICAL JUNCTION CAPACITANCE

