

**T-1 3/4 General Purpose LED Lamps**

**DESCRIPTION AND FEATURES**

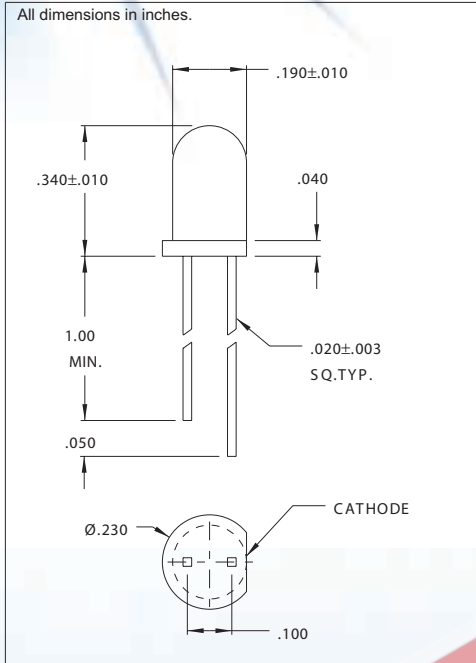

The HLMP33XX series are direct replacements for Hewlett Packard's HLMP33XX series. The FLV110 is a direct replacement for Fairchild's FLV110. These LED lamps are available with wide or narrow viewing angles for direct viewing or backlighting. The standard red lamp is produced with GaAsP and the High Efficiency Red lamps are produced with GaAsP/GaP. Lamps are available either diffused or non-diffused.

**ELECTRO-OPTICAL CHARACTERISTICS AND RATINGS**

PART NUMBER	HLMP3300	HLMP3301	HLMP3315	HLMP3316	FLV110
Output Color	H.E. Red	H.E. Red	H.E. Red	H.E. Red	Red
Diffusion	Diffused	Diffused	Non-Diffused	Non-Diffused	Diffused
Package Color	Red	Red	Red	Red	Red
Test Current (mA)	10	10	10	10	20
Forward Voltage Typ. (V)	2.2	2.2	2.2	2.2	1.6
Forward Voltage Max. (V)	3.0	3.0	3.0	3.0	2.0
Luminous Intensity Min. (mcd)	2.0	4.0	12.0	20.0	0.8
Luminous Intensity Typ. (mcd)	3.5	7.0	18.0	35.0	3.0
Capacitance pF Vr=0, F=1MHz	45	45	45	45	30
Peak Wavelength (nm)	635	635	635	635	665
Viewing Angle 2θ 1/2 (degrees)	65	65	35	35	70
Power Dissipation (mW)	135	135	135	135	135
Operating Temperature (°C)	-55 to +100	-55 to +100	-55 to +100	-55 to +100	-55 to +100
Storage Temperature (°C)	-55 to +100	-55 to +100	-55 to +100	-55 to +100	-55 to +100
Peak Forward Current Max. (1µs @ 0.3% duty cycle) (mA)	90	90	90	90	90
Reverse Voltage (IR=100µA) (V)	5	5	5	5	5
Lead Solder Time @ 260°C	5	5	5	5	5