



## Frequency Generator for P IV™

### Recommended Application:

P IV Chipset Support

### Output Features:

- 4 Differential CPU Clock Pairs @ 3.3V
- 2 - 3V MREF clocks for memory reference seeds, (separate single ended but 180 degrees out of phase)
- 4 - 66MHz reference output
- 10 - 3V 33MHz PCI clocks
- 2 - 48MHz clocks
- 2 - 14.318 reference output

### Features:

- Support power management: Power Down Mode
- Supports Spread Spectrum modulation: 0 to -0.5% down spread.
- Uses external 14.318MHz crystal
- Select logic for Differential Swing Control, Test mode, Tristate, Power down, Spread Spectrum, limited frequency select, selective clock enable.
- External resistor for current reference
- FS pins for frequency select

### Key Specifications:

- 3V66 Output jitter <300ps
- CPU Output Jitter <200ps
- MREF Output jitter <250ps

### Pin Configuration

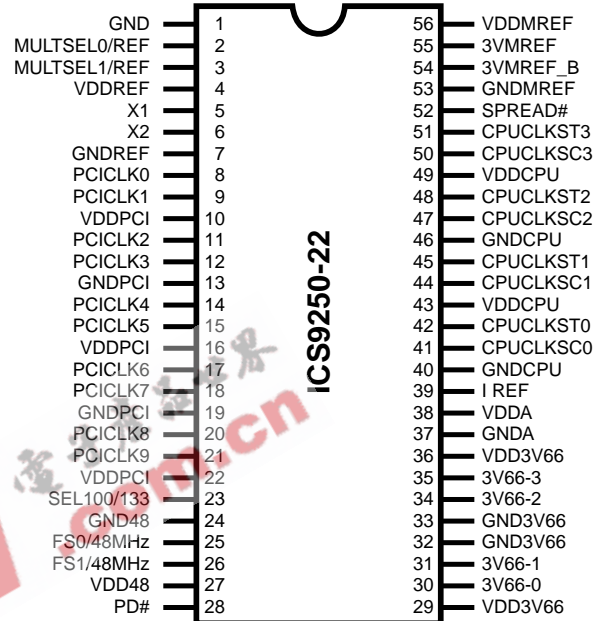

**56-Pin 300mil SSOP & TSSOP**

### Functionality

SEL133/100	FS0	FS1	Function
0	0	0	Active 100MHz
0	0	1	(Reserved)
0	1	0	(Reserved)
0	1	1	Tristate all outputs
1	0	0	Active 133MHz
1	0	1	(Reserved)
1	1	0	(Reserved)
1	1	1	Test Mode

### Power Groups

VDDREF, GNDREF= REF, X1, X2  
 VDDPCI, GNDPCI = PCICLK  
 VDD48, GND48 = 48MHz, PLL2  
 VDD3V66, GND3V66=3V66  
 VDDCPU, GNDCPU = CPUCLK  
 VDDMREF, GNDMREF=3VMREF, 3VMREF\_B  
 VDDA=VDD (core supply voltage 3.3V)  
 GNDA=Ground for core supply

### Block Diagram

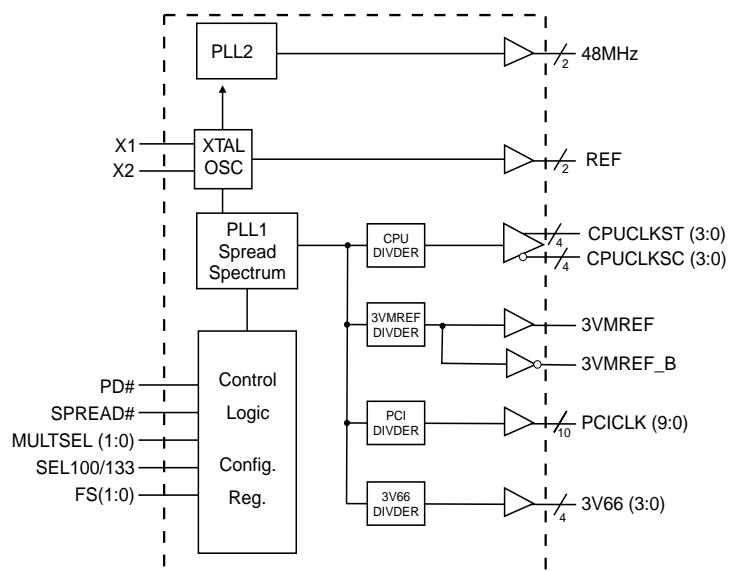

# ICS9250-22



## General Description

The ICS9250-22 is a single chip clock solution.

Spread spectrum typically reduces system EMI by 8dB to 10dB. This simplifies EMI qualification without resorting to board design iterations or costly shielding. The ICS9250-22 employs a proprietary closed loop design, which tightly controls the percentage of spreading over process and temperature variations.

## Pin Configuration

PIN NUMBER	PIN NAME	TYPE	DESCRIPTION
1, 7, 13, 19, 24, 32, 33, 37, 40, 46, 53	GND	PWR	Ground pins for 3.3V supply
3, 2	REF/MULTSEL (1:0)	IN	MULTSEL0 and MULTSEL1 inputs are sensed on power-up and then internally latched prior to the pin being used for output on 3V 14.318MHz clocks.
4, 10, 16, 22, 27, 29, 36, 38, 43, 49, 56	VDD	PWR	3.3V power supply
5	X1	X2 Crystal Input	14.318MHz Crystal input
6	X2	X1 Crystal Output	14.318MHz Crystal output
21, 20, 18, 17, 15, 14, 12, 11, 9, 8	PCICLK (9:0)	OUT	PCI clock outputs
23	SEL100/133	IN	CPU Frequency Select. Low=100MHz, High=133MHz
26, 25	FS (1:0)	IN	Frequency select pins
	48MHz	OUT	48MHz clock output
28	PD#	IN	Invokes power-down mode. Active Low.
35, 34, 31, 30	3V66 (3:0)	OUT	66MHz reference clocks
39	I REF	OUT	This pin establishes the reference current for the CPUCLK pairs. This pin takes a fixed precision resistor tied to ground in order to establish the appropriate current.
51, 48, 45, 42	CPUCLKST (3:0)	OUT	"True" clocks of differential pair CPU outputs. These are switched current outputs and external resistors are required for voltage bias.
50, 47, 44, 41	CPUCLKSC (3:0)	OUT	"Complementary" clocks of differential pair CPU outputs. These are switched current outputs and external resistors are required for voltage bias.
52	SPREAD#	IN	Invokes Spread Spectrum functionality on the Differential host clocks, MRef/MRef_b clocks, 66MHz clocks, and 33MHz PCI clocks. Active Low
54	3VMREF_B	OUT	3V reference to memory clock driver (out of phase with 3Vmref)
55	3VMREF	OUT	3V reference to memory clock driver



**Truth Table**

SEL 133/100	FS0	FS1	CPU	MRef	3V66	PCI	48MHz	REF
0	0	0	100MHz	50MHz	66MHz	33MHz	48MHz	14.318MHz
0	0	1	N/A	N/A	N/A	N/A	N/A	N/A
0	1	0	N/A	N/A	N/A	N/A	N/A	N/A
0	1	1	Tristate	Tristate	Tristate	Tristate	Tristate	Tristate
1	0	0	133MHz	66MHz	66MHz	33MHz	48MHz	14.318MHz
1	0	1	N/A	N/A	N/A	N/A	N/A	N/A
1	1	0	N/A	N/A	N/A	N/A	N/A	N/A
1	1	1	TCLK/2	TCLK/4	TCLK	TCLK/6		TCLK

**Group Offset Limits**

Group	Offset	Measurement Loads (lumped)	Measure Points
CPU to 3V66	No Requirement		
CPU to PCI			
3V66 to PCI	1.5 - 3.5ns 3V66 leads	30pF	1.5V



## CPUCLK Buffer Configuration

	Conditions	Configuration	Load	Min	Max
<b>Iout</b>	Vdd = nominal (3.30V)	All combinations of M0, M1 and Rr shown in table below	Nominal test load for given configuration	-7% I nominal	+7% I nominal
<b>Iout</b>	Vdd = 3.30 ± 5%	All combinations of M0, M1 and Rr shown in table below	Nominal test load for given configuration	-12% I nominal	+12% I nominal

## CPUCLK Swing Select Functions

MULTSEL0	MULTSEL1	Board Target Trace/Term Z	Reference R, Iref= Vdd/(3*Rr)	Output Current	Voh @ Z, Iref=2.32mA
0	0	60 ohms	Rr = 475 1% Iref = 2.32mA	Ioh = 5*Iref	0.71V @ 60
0	0	50 ohms	Rr = 475 1% Iref = 2.32mA	Ioh = 5*Iref	0.59V @ 50
0	1	60 ohms	Rr = 475 1% Iref = 2.32mA	Ioh = 6*Iref	0.85V /2 60
0	1	50 ohms	Rr = 475 1% Iref = 2.32mA	Ioh = 6*Iref	0.71V @ 50
1	0	60 ohms	Rr = 475 1% Iref = 2.32mA	Ioh = 4*Iref	0.56V @ 60
1	0	50 ohms	Rr = 475 1% Iref = 2.32mA	Ioh = 4*Iref	0.47V @ 50
1	1	60 ohms	Rr = 475 1% Iref = 2.32mA	Ioh = 7*Iref	0.99V @ 60
1	1	50 ohms	Rr = 475 1% Iref = 2.32mA	Ioh = 7*Iref	0.82V @ 50
0	0	30 (DC equiv)	Rr = 221 1% Iref = 5mA	Ioh = 5*Iref	0.75V @ 30
0	0	25 (DC equiv)	Rr = 221 1% Iref = 5mA	Ioh = 5*Iref	0.62V @ 20
0	1	30 (DC equiv)	Rr = 221 1% Iref = 5mA	Ioh = 6*Iref	0.90V @ 30
0	1	25 (DC equiv)	Rr = 221 1% Iref = 5mA	Ioh = 6*Iref	0.75V @ 20
1	0	30 (DC equiv)	Rr = 221 1% Iref = 5mA	Ioh = 4*Iref	0.60 @ 20
1	0	25 (DC equiv)	Rr = 221 1% Iref = 5mA	Ioh = 4*Iref	0.5V @ 20
1	1	30 (DC equiv)	Rr = 221 1% Iref = 5mA	Ioh = 7*Iref	1.05V @ 30
1	1	25 (DC equiv)	Rr = 221 1% Iref = 5mA	Ioh = 7*Iref	0.84V @ 20



### Absolute Maximum Ratings

Supply Voltage	5.5 V
Logic Inputs	GND -0.5 V to V <sub>DD</sub> +0.5 V
Ambient Operating Temperature	0°C to +70°C
Case Temperature	115°C
Storage Temperature	-65°C to +150°C

Stresses above those listed under *Absolute Maximum Ratings* may cause permanent damage to the device. These ratings are stress specifications only and functional operation of the device at these or any other conditions above those listed in the operational sections of the specifications is not implied. Exposure to absolute maximum rating conditions for extended periods may affect product reliability.

### Electrical Characteristics - Input/Supply/Common Output Parameters

T<sub>A</sub> = 0 - 70C; Supply Voltage V<sub>DD</sub> = 3.3 V +/-5%

PARAMETER	SYMBOL	CONDITIONS	MIN	TYP	MAX	UNITS
Input High Voltage	V <sub>IH</sub>		2		V <sub>DD</sub> +0.3	V
Input Low Voltage	V <sub>IL</sub>		V <sub>SS</sub> -0.3		0.8	V
Input High Current	I <sub>IH</sub>	V <sub>IN</sub> = V <sub>DD</sub>	-5		5	μA
Input Low Current	I <sub>IL1</sub>	V <sub>IN</sub> = 0 V; Inputs with no pull-up resistors	-5			μA
	I <sub>IL2</sub>	V <sub>IN</sub> = 0 V; Inputs with pull-up resistors	-200			
Operating Supply Current	I <sub>DD3.3OP</sub>	C <sub>L</sub> = 0 pF; Select @ 100 MHz		130	250	mA
Powerdown Current	I <sub>DD3.3PD</sub>	C <sub>L</sub> = 0 pF; Input address to VDD or GND		35	60	mA
Input Frequency	F <sub>i</sub>	V <sub>DD</sub> = 3.3 V		14.318		MHz
Pin Inductance	L <sub>pin</sub>				7	nH
Input Capacitance <sup>1</sup>	C <sub>IN</sub>	Logic Inputs			5	pF
	C <sub>OUT</sub>	Output pin capacitance			6	pF
	C <sub>INX</sub>	X1 & X2 pins	27		45	pF
Transition time <sup>1</sup>	T <sub>trans</sub>	To 1st crossing of target frequency			3	ms
Settling time <sup>1</sup>	T <sub>s</sub>	From 1st crossing to 1% target frequency			3	ms
Clk Stabilization <sup>1</sup>	T <sub>STAB</sub>	From V <sub>DD</sub> = 3.3 V to 1% target frequency			3	ms
Delay <sup>1</sup>	t <sub>PZH</sub> , t <sub>PZL</sub>	Output enable delay (all outputs)	1		10	ns
	t <sub>PHZ</sub> , t <sub>PLZ</sub>	Output disable delay (all outputs)	1		10	ns

<sup>1</sup>Guaranteed by design, not 100% tested in production.

# ICS9250-22



## Electrical Characteristics - CPU

$T_A = 0 - 70^\circ\text{C}$ ;  $V_{DD} = 3.3\text{V} \pm 5\%$ ;  $C_L = 10\text{-}20\text{ pF}$  (unless otherwise specified)

PARAMETER	SYMBOL	CONDITIONS	MIN	TYP	MAX	UNITS
Output Impedance	$R_{DSP2B}^1$	$V_O = V_{DD} * (0.5)$		714		$\Omega$
Output Impedance	$R_{DSN2B}^1$	$V_O = V_{DD} * (0.5)$		714		$\Omega$
Output High Voltage	$V_{OH2B}$	$I_{OH} = -1\text{ mA}$	2			V
Output Low Voltage	$V_{OL2B}$	$I_{OL} = 1\text{ mA}$			0.4	V
Output High Current	$I_{OH2B}^2$	$V_{OH@MIN} = 1.0\text{ V}$ , $V_{OH@MAX} = 2.375\text{ V}$	-27		-27	mA
Output Low Current	$I_{OL2B}^2$	$V_{OL@MIN} = 1.2\text{ V}$ , $V_{OL@MAX} = 0.3\text{ V}$	27		30	mA
Rise Time	$t_{r2B}^1$	$V_{OL} = 20\%$ , $V_{OH} = 80\%$	175	500	700	ps
Fall Time	$t_{f2B}^1$	$V_{OH} = 80\%$ , $V_{OL} = 20\%$	175	500	700	ps
Duty Cycle	$d_{t2B}^1$	$V_T = 50\%$	45	51	55	%
Skew	$t_{sk2B}^1$	$V_T = 50\%$		110	150	ps
Jitter	$t_{jycyc-cyc}^1$	$V_T = 50\%$		110	200	ps

<sup>1</sup>Guaranteed by design, not 100% tested in production.

<sup>2</sup> $I_{OwT}$  can be varied and is selectable thru the MULTSEL pin.

## Electrical Characteristics - PCI

$T_A = 0 - 70^\circ\text{C}$ ;  $V_{DD} = 3.3\text{V} \pm 5\%$ ;  $C_L = 10\text{-}30\text{ pF}$  (unless otherwise specified)

PARAMETER	SYMBOL	CONDITIONS	MIN	TYP	MAX	UNITS
Output Frequency	$F_{O1}$					MHz
Output Impedance	$R_{DSP1}^1$	$V_O = V_{DD} * (0.5)$	12	33	55	$\Omega$
Output High Voltage	$V_{OH}^1$	$I_{OH} = -1\text{ mA}$	2.4			V
Output Low Voltage	$V_{OL}^1$	$I_{OL} = 1\text{ mA}$			0.55	V
Output High Current	$I_{OH}^1$	$V_{OH@MIN} = 1.0\text{ V}$ , $V_{OH@MAX} = 3.135\text{ V}$	-33		-33	mA
Output Low Current	$I_{OL}^1$	$V_{OL@MIN} = 1.95\text{ V}$ , $V_{OL@MAX} = 0.4\text{ V}$	30		38	mA
Rise Time	$t_{r1}^1$	$V_{OL} = 0.4\text{ V}$ , $V_{OH} = 2.4\text{ V}$	0.5	1.4	2	ns
Fall Time	$t_{f1}^1$	$V_{OH} = 2.4\text{ V}$ , $V_{OL} = 0.4\text{ V}$	0.5	1.4	2	ns
Duty Cycle	$d_{t1}^1$	$V_T = 1.5\text{ V}$	45	51	55	%
Skew	$t_{sk1}^1$	$V_T = 1.5\text{ V}$		270	500	ps
Jitter	$t_{jycyc-cyc}^1$	$V_T = 1.5\text{ V}$		115	500	ps

<sup>1</sup>Guaranteed by design, not 100% tested in production.



### Electrical Characteristics - MREF/MREF\_B

T<sub>A</sub> = 0 - 70°C; VDD=3.3V +/-5%; C<sub>L</sub> = 10-20 pF (unless otherwise specified)

PARAMETER	SYMBOL	CONDITIONS	MIN	TYP	MAX	UNITS
Output Frequency	F <sub>O1</sub>					MHz
Output Impedance	R <sub>DSP1</sub> <sup>1</sup>	V <sub>O</sub> = V <sub>DD</sub> *(0.5)	12	33	55	Ω
Output High Voltage	V <sub>OH</sub> <sup>1</sup>	I <sub>OH</sub> = -1 mA	2.4			V
Output Low Voltage	V <sub>OL</sub> <sup>1</sup>	I <sub>OL</sub> = 1 mA			0.55	V
Output High Current	I <sub>OH</sub> <sup>1</sup>	V <sub>OH@MIN</sub> = 1.0 V, V <sub>OH@MAX</sub> = 3.135 V	-33		-33	mA
Output Low Current	I <sub>OL</sub> <sup>1</sup>	V <sub>OL@MIN</sub> = 1.95 V, V <sub>OL@MAX</sub> = 0.4 V	30		38	mA
Rise Time	t <sub>r1</sub> <sup>1</sup>	V <sub>OL</sub> = 0.4 V, V <sub>OH</sub> = 2.4 V	0.4	1.4	1.6	ns
Fall Time	t <sub>fl</sub> <sup>1</sup>	V <sub>OH</sub> = 2.4 V, V <sub>OL</sub> = 0.4 V	0.4	1.4	1.6	ns
Duty Cycle	d <sub>tl</sub> <sup>1</sup>	V <sub>T</sub> = 1.5 V	45	51	55	%
Skew	t <sub>sk1</sub> <sup>1</sup>	V <sub>T</sub> = 1.5 V		80	100	ps
Jitter	t <sub>jyc-cyc</sub> <sup>1</sup>	V <sub>T</sub> = 1.5 V		105	250	ps

<sup>1</sup>Guaranteed by design, not 100% tested in production.

### Electrical Characteristics - REF

T<sub>A</sub> = 0 - 70°C; VDD=3.3V +/-5%; C<sub>L</sub> = 10-20 pF (unless otherwise specified)

PARAMETER	SYMBOL	CONDITIONS	MIN	TYP	MAX	UNITS
Output Frequency	F <sub>O1</sub>					MHz
Output Impedance	R <sub>DSP1</sub> <sup>1</sup>	V <sub>O</sub> = V <sub>DD</sub> *(0.5)	20	48	60	Ω
Output High Voltage	V <sub>OH</sub> <sup>1</sup>	I <sub>OH</sub> = -1 mA	2.4			V
Output Low Voltage	V <sub>OL</sub> <sup>1</sup>	I <sub>OL</sub> = 1 mA			0.4	V
Output High Current	I <sub>OH</sub> <sup>1</sup>	V <sub>OH@MIN</sub> = 1.0 V, V <sub>OH@MAX</sub> = 3.135 V	-29		-23	mA
Output Low Current	I <sub>OL</sub> <sup>1</sup>	V <sub>OL@MIN</sub> = 1.95 V, V <sub>OL@MAX</sub> = 0.4 V	29		27	mA
Rise Time	t <sub>r1</sub> <sup>1</sup>	V <sub>OL</sub> = 0.4 V, V <sub>OH</sub> = 2.4 V	1	2	4	ns
Fall Time	t <sub>fl</sub> <sup>1</sup>	V <sub>OH</sub> = 2.4 V, V <sub>OL</sub> = 0.4 V	1	2	4	ns
Duty Cycle	d <sub>tl</sub> <sup>1</sup>	V <sub>T</sub> = 1.5 V	45	50	55	%
Skew	t <sub>sk1</sub> <sup>1</sup>	V <sub>T</sub> = 1.5 V			N/A	ps
Jitter	t <sub>jyc-cyc</sub> <sup>1</sup>	V <sub>T</sub> = 1.5 V		205	1000	ps

<sup>1</sup>Guaranteed by design, not 100% tested in production.

# ICS9250-22



## Electrical Characteristics - 3V66

T<sub>A</sub> = 0 - 70°C; VDD=3.3V +/-5%; C<sub>L</sub> = 10-30 pF (unless otherwise specified)

PARAMETER	SYMBOL	CONDITIONS	MIN	TYP	MAX	UNITS
Output Frequency	F <sub>O1</sub>					MHz
Output Impedance	R <sub>DSP1</sub> <sup>1</sup>	V <sub>O</sub> = V <sub>DD</sub> *(0.5)	12	33	55	Ω
Output High Voltage	V <sub>OH</sub> <sup>1</sup>	I <sub>OH</sub> = -1 mA	2.4			V
Output Low Voltage	V <sub>OL</sub> <sup>1</sup>	I <sub>OL</sub> = 1 mA			0.55	V
Output High Current	I <sub>OH</sub> <sup>1</sup>	V <sub>OH@MIN</sub> = 1.0 V, V <sub>OH@MAX</sub> = 3.135 V	-33		-33	mA
Output Low Current	I <sub>OL</sub> <sup>1</sup>	V <sub>OL@MIN</sub> = 1.95 V, V <sub>OL@MAX</sub> = 0.4 V	30		38	mA
Rise Time	t <sub>rl</sub> <sup>1</sup>	V <sub>OL</sub> = 0.4 V, V <sub>OH</sub> = 2.4 V	0.5	1.3	2	ns
Fall Time	t <sub>fl</sub> <sup>1</sup>	V <sub>OH</sub> = 2.4 V, V <sub>OL</sub> = 0.4 V	0.5	1.3	2	ns
Duty Cycle	d <sub>tl</sub> <sup>1</sup>	V <sub>T</sub> = 1.5 V	45	51	55	%
Skew	t <sub>sk1</sub> <sup>1</sup>	V <sub>T</sub> = 1.5 V		85	250	ps
Jitter	t <sub>jycyc-cyc</sub> <sup>1</sup>	V <sub>T</sub> = 1.5 V		80	300	ps

<sup>1</sup>Guaranteed by design, not 100% tested in production.

## Electrical Characteristics - 48MHz

T<sub>A</sub> = 0 - 70°C; VDD=3.3V +/-5%; C<sub>L</sub> = 10-20 pF (unless otherwise specified)

PARAMETER	SYMBOL	CONDITIONS	MIN	TYP	MAX	UNITS
Output Frequency	F <sub>O1</sub>					MHz
Output Impedance	R <sub>DSP1</sub> <sup>1</sup>	V <sub>O</sub> = V <sub>DD</sub> *(0.5)	20	48	60	Ω
Output High Voltage	V <sub>OH</sub> <sup>1</sup>	I <sub>OH</sub> = -1 mA	2.4			V
Output Low Voltage	V <sub>OL</sub> <sup>1</sup>	I <sub>OL</sub> = 1 mA			0.4	V
Output High Current	I <sub>OH</sub> <sup>1</sup>	V <sub>OH@MIN</sub> = 1.0 V, V <sub>OH@MAX</sub> = 3.135 V	-29		-23	mA
Output Low Current	I <sub>OL</sub> <sup>1</sup>	V <sub>OL@MIN</sub> = 1.95 V, V <sub>OL@MAX</sub> = 0.4 V	29		27	mA
Rise Time	t <sub>rl</sub> <sup>1</sup>	V <sub>OL</sub> = 0.4 V, V <sub>OH</sub> = 2.4 V	1	2	4	ns
Fall Time	t <sub>fl</sub> <sup>1</sup>	V <sub>OH</sub> = 2.4 V, V <sub>OL</sub> = 0.4 V	1	2	4	ns
Duty Cycle	d <sub>tl</sub> <sup>1</sup>	V <sub>T</sub> = 1.5 V	45	54	55	%
Skew	t <sub>sk1</sub> <sup>1</sup>	V <sub>T</sub> = 1.5 V			N/A	ps
Jitter	t <sub>jycyc-cyc</sub> <sup>1</sup>	V <sub>T</sub> = 1.5 V		120	350	ps

<sup>1</sup>Guaranteed by design, not 100% tested in production.





### PD# Timing Diagram

The power down selection is used to put the part into a very low power state without turning off the power to the part. PD# is an asynchronous active low input. This signal needs to be synchronized internal to the device prior to powering down the clock synthesizer.

Internal clocks are not running after the device is put in power down. When PD# is active low all clocks need to be driven to a low value and held prior to turning off the VCOs and crystal. The power up latency needs to be less than 3 mS. The power down latency should be as short as possible but conforming to the sequence requirements shown below.

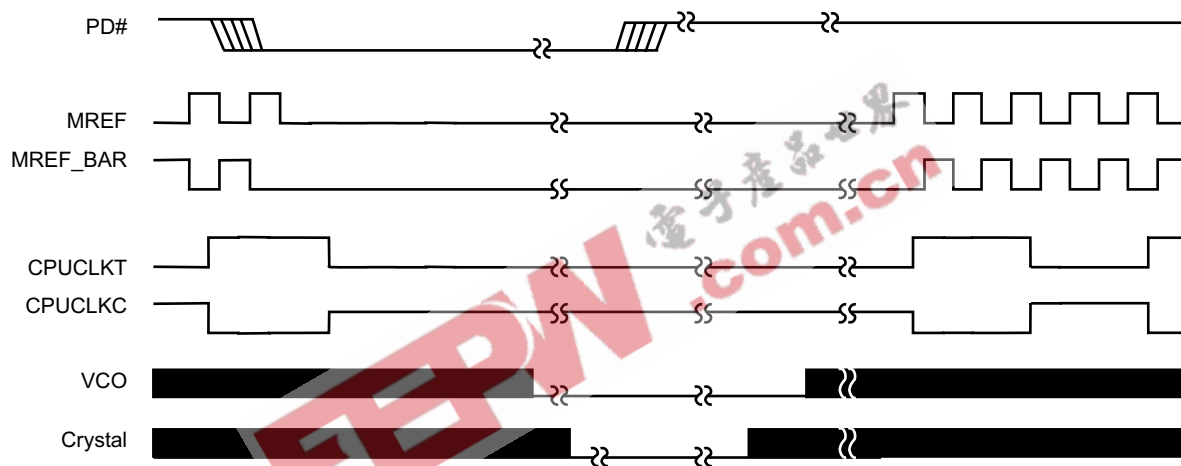

**Notes:**

- 1. As shown, the outputs Stop Low on the next falling edge after PD# goes low.
- 2. PD# is an asynchronous input and metastable conditions may exist. This signal is synchronized inside this part.
- 3. The shaded sections on the VCO and the Crystal signals indicate an active clock.

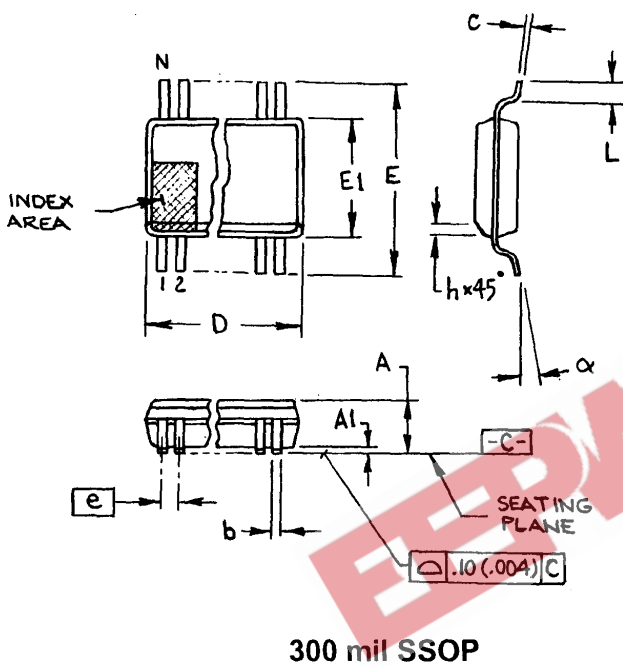

SYMBOL	In Millimeters COMMON DIMENSIONS		In Inches COMMON DIMENSIONS	
	MIN	MAX	MIN	MAX
A	2.413	2.794	.095	.110
A1	0.203	0.406	.008	.016
b	0.203	0.343	.008	.0135
c	0.127	0.254	.005	.010
D	SEE VARIATIONS		SEE VARIATIONS	
E	10.033	10.668	.395	.420
E1	7.391	7.595	.291	.299
e	0.635 BASIC		0.025 BASIC	
h	0.381	0.635	.015	.025
L	0.508	1.016	.020	.040
N	SEE VARIATIONS		SEE VARIATIONS	
α	0°	8°	0°	8°

VARIATIONS

N	D mm.		D (inch)	
	MIN	MAX	MIN	MAX
56	18.288	18.542	.720	.730

JEDEC MO-118  
DOC# 10-0034  
6/1/00  
REV B

Ordering Information

ICS9250yF-22-T

Example:

ICS XXXX y F - PPP - T

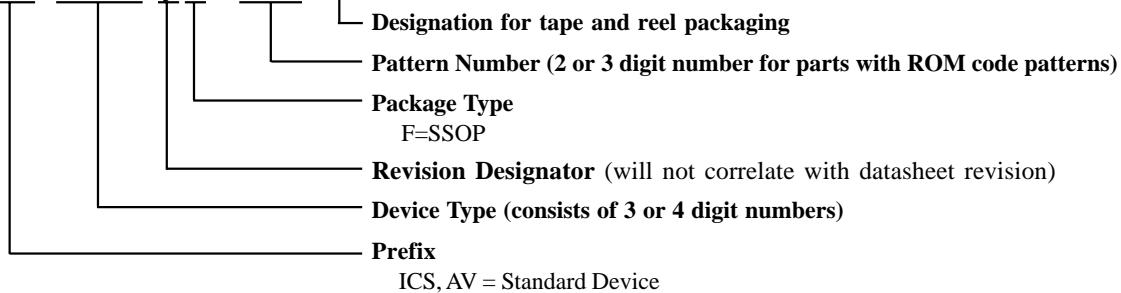

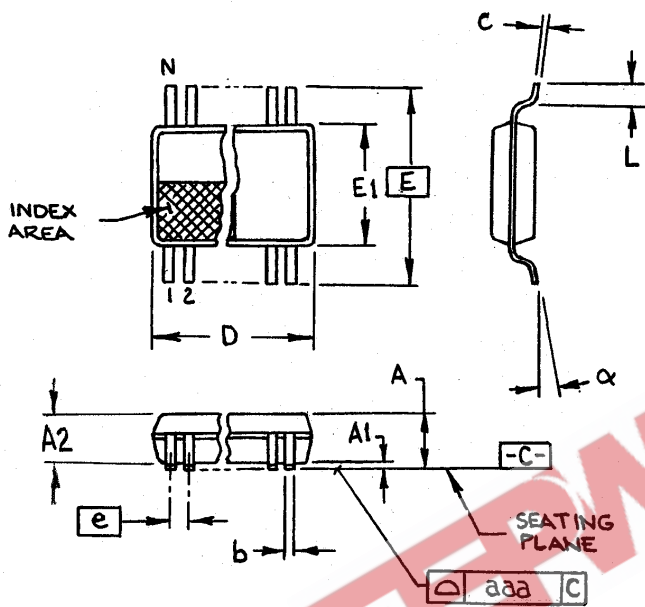

6.10 mm. Body, 0.50 mm. pitch TSSOP  
(240 mil) (0.020 mil)

SYMBOL	In Millimeters		In Inches	
	COMMON DIMENSIONS		COMMON DIMENSIONS	
	MIN	MAX	MIN	MAX
A	-	1.20	-	.047
A1	0.05	0.15	.002	.006
A2	0.80	1.05	.032	.041
b	0.17	0.27	.007	.011
c	0.09	0.20	.0035	.008
D	SEE VARIATIONS		SEE VARIATIONS	
E	8.10 BASIC		0.319	
E1	6.00	6.20	.236	.244
e	0.50 BASIC		0.020 BASIC	
L	0.45	0.75	.018	.30
N	SEE VARIATIONS		SEE VARIATIONS	
$\alpha$	0°	8°	0°	8°
aaa	-	0.10	-	.004

VARIATIONS

N	D mm.		D (inch)	
	MIN	MAX	MIN	MAX
56	13.90	14.10	.547	.555

MO-153 JEDEC Doc.# 10-0039 7/8/00 Rev B

Ordering Information

ICS9250yG-22-T

Example:

ICS XXXX y G - PPP - T

