

Low Skew Output Buffer

General Description

The ICS9112-26 is a high performance, low skew, low jitter clock driver. It is designed to distribute high speed clocks in PC systems operating at speeds from 0 to 133 MHz.

The ICS9112-26 comes in an eight pin 150 mil SOIC package. It has four output clocks.

Features

- Frequency range 0 - 133 MHz (3.3V)
- Less than 200 ps Jitter between outputs
- Skew controlled outputs
- Skew less than 250 ps between outputs
- Available in 8 pin 150 mil SOIC & 173 mil TSSOP packages.
- 3.3V \pm 10% operation

Block Diagram

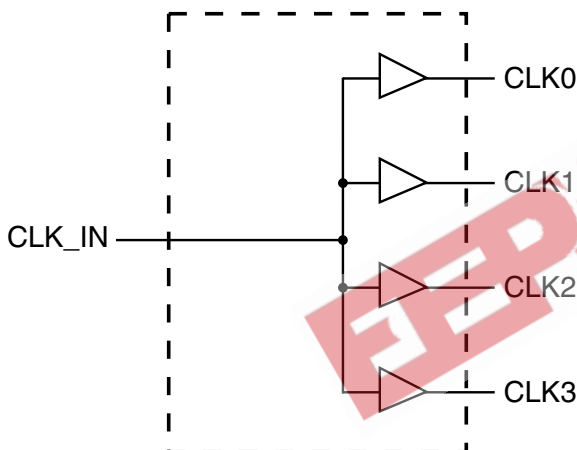

Pin Configuration

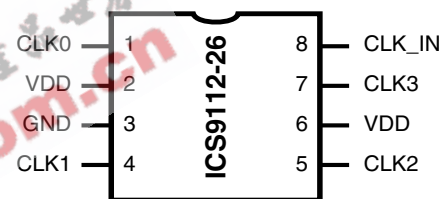

8 pin SOIC & TSSOP

Pin Descriptions

PIN NUMBER	PIN NAME	TYPE	DESCRIPTION
1	CLK0 ¹	OUT	Buffered clock output
2,6	VDD	PWR	Power Supply (3.3V)
3	GND	PWR	Ground
4	CLK1 ¹	OUT	Buffered clock output
5	CLK2 ¹	OUT	Buffered clock output
7	CLK3 ¹	OUT	Buffered clock output
8	CLK_IN	IN	Input reference frequency.

Notes:

1. Weak pull-down on all outputs

ICS9112-26



Absolute Maximum Ratings

Supply Voltage	7.0 V
Logic Inputs	GND -0.5 V to $V_{DD} + 0.5$ V
Ambient Operating Temperature	0°C to +70°C
Storage Temperature	-65°C to +150°C

Stresses above those listed under *Absolute Maximum Ratings* may cause permanent damage to the device. These ratings are stress specifications only and functional operation of the device at these or any other conditions above those listed in the operational sections of the specifications is not implied. Exposure to absolute maximum rating conditions for extended periods may affect product reliability.

Electrical Characteristics at 3.3V

$T_A = 0 - 70$ C; Supply Voltage $V_{DD} = 3.3$ V +/-5% (unless otherwise stated)

PARAMETER	SYMBOL	CONDITIONS	MIN	TYP	MAX	UNITS
High-level Output Voltage	V_{OH}	$V_{DD} = \text{min to max}, I_{OH} = -1$ mA	$V_{DD} - 0.2$	3.3		V
		$V_{DD} = 3$ V, $I_{OH} = -24$ mA	2	2.9		V
		$V_{DD} = 3$ V, $I_{OH} = 12$ mA	2.4	3.1		V
Low-level Output Voltage	V_{OL}	$V_{DD} = \text{min to max}, I_{OH} = 1$ mA		0.0055	0.2	V
		$V_{DD} = 3$ V, $I_{OH} = 24$ mA		0.28	0.8	V
		$V_{DD} = 3$ V, $I_{OH} = 12$ mA		0.14	0.55	V
High-level Input Current	I_{OH}	$V_{DD} = 3$ V, $V_O = 1$ V		-61	-50	
		$V_{DD} = 3.3$ V, $V_O = 1.65$ V		-77		
Low-level Input Current	I_{OL}	$V_{DD} = 3$ V, $V_O = 2$ V	60	103		
		$V_{DD} = 3.3$ V, $V_O = 1.65$ V		111		
Input Current	I_I	$V = V_O$ or V_{DD}	-5		5	μ A
Input Capacitance ¹	C_I	$V_{DD} = 3.3$ V, $V_I = 0$ V or 3.3V		3		pF
Output Capacitance ¹	C_O	$V_{DD} = 3.3$ V, $V_I = 0$ V or 3.3V		3.2		pF
Supply current	I_{DD}	REF = 0 MHz		22	50	μ A
		Unloaded outputs at 66.67 MHz		25	40	mA

1. Guaranteed by design, not 100% tested in production.

Switching Characteristics at 3.3V

$T_A = 0 - 70$ C; Supply Voltage $V_{DD} = 3.3$ V +/-5% (unless otherwise stated)

PARAMETER	SYMBOL	CONDITIONS	MIN	TYP	MAX	UNITS
Low-to-high Propagation Delay ¹	t_{PLH}	$V_O = V_{DD}/2$	4	5.6	7	ns
High-to-low Propagation Delay ¹	t_{PHL}	$V_O = V_{DD}/2$	4	5.2	7	ns
Output Skew Window ¹	$T_{sk}(O)$	$V_O = V_{DD}/2$		50	100	ps
Process Skew ¹	$T_{sk}(PR)$	$V_O = V_{DD}/2$			0.5	ps
CLKIN High Time ¹	T_{high}	66 MHz	6			ns
		133 MHz	3			
CLKIN Low Time ¹	T_{low}	66 MHz	6			ns
		133 MHz	3			
Output Rise Slew Rate ¹	T_r	0.3 to 0.6 V_{DD}	2	3.6	5	V/ns
Output Rise Slew Rate ¹	T_f	0.3 to 0.6 V_{DD}	2	3.2	5	V/ns

1. Guaranteed by design, not 100% tested in production.

Notes:

- Guaranteed by design and characterization. Not subject to 100% test.
- CLK_IN input has a threshold voltage of 1.4V
- All parameters expected with loaded outputs

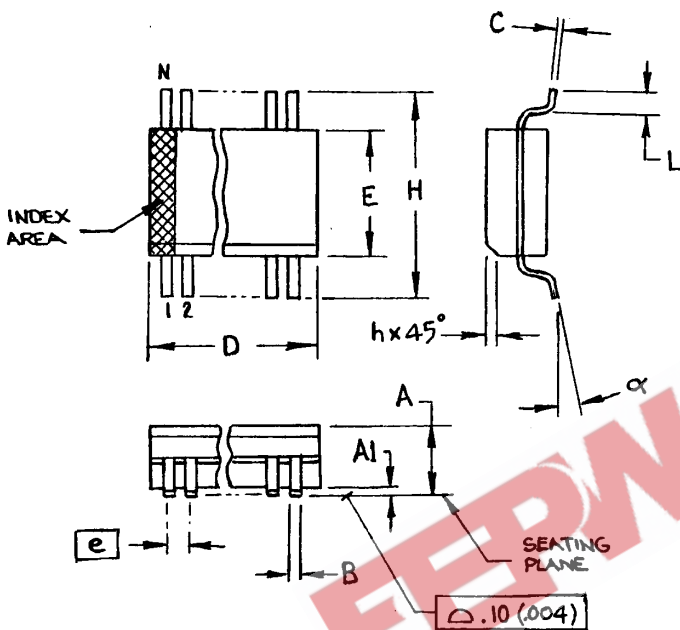

SYMBOL	In Millimeters COMMON DIMENSIONS		In Inches COMMON DIMENSIONS	
	MIN	MAX	MIN	MAX
A	1.35	1.75	.0532	.0688
A1	0.10	0.25	.0040	.0098
B	0.33	0.51	.013	.020
C	0.19	0.25	.0075	.0098
D	SEE VARIATIONS		SEE VARIATIONS	
E	3.80	4.0	.1497	.1574
e	1.27 BASIC		0.050 BASIC	
H	5.80	6.20	.2284	.2440
h	0.25	0.50	.010	.020
L	0.40	1.27	.016	.050
N	SEE VARIATIONS		SEE VARIATIONS	
α	0°	8°	0°	8°

VARIATIONS

N	D mm.		D (inch)	
	MIN	MAX	MIN	MAX
8	4.80	5.00	.1890	.1968

150 mil (Narrow Body) SOIC

Ordering Information

ICS9112yM-26-T

Example:

ICS XXXX y M - PPP - T

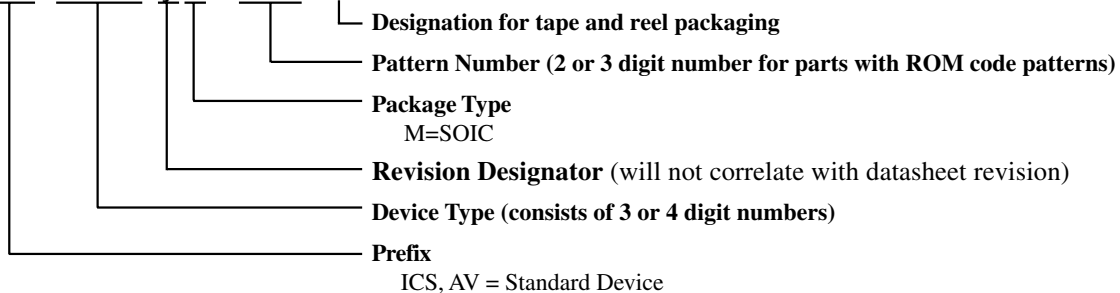

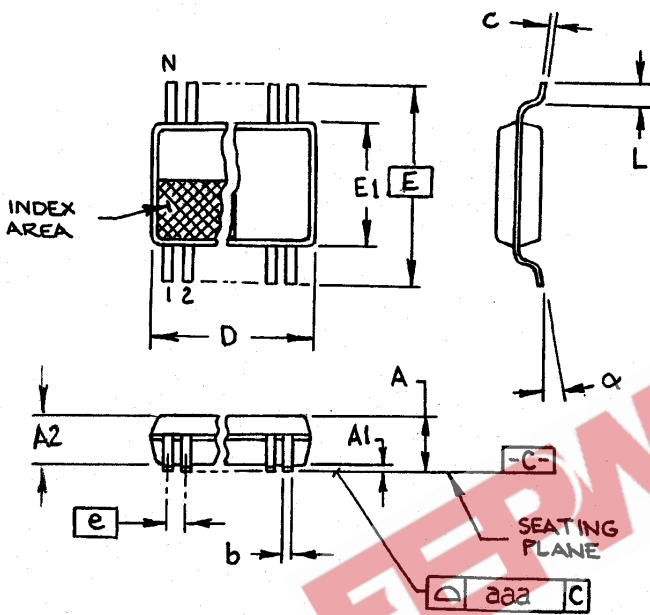

4.40 mm. Body, 0.65 mm. pitch TSSOP
(173 mil) (0.0256 mil)

SYMBOL	In Millimeters		In Inches	
	COMMON DIMENSIONS		COMMON DIMENSIONS	
	MIN	MAX	MIN	MAX
A	-	1.20	-	.047
A1	0.05	0.15	.002	.006
A2	0.80	1.05	.032	.041
b	0.19	0.30	.007	.012
c	0.09	0.20	.0035	.008
D	SEE VARIATIONS		SEE VARIATIONS	
E	6.40 BASIC		0.252 BASIC	
E1	4.30	4.50	.169	.177
e	0.65 BASIC		0.0256 BASIC	
L	0.45	0.75	.018	.030
N	SEE VARIATIONS		SEE VARIATIONS	
alpha	0°	8°	0°	8°
aaa	-	0.10	-	.004

VARIATIONS

N	D mm.		D (inch)	
	MIN	MAX	MIN	MAX
8	2.90	3.10	.114	.122

MO-153 JEDEC 7/8/00 Rev B
Doc.# 10-0038

Ordering Information

ICS9112yG-26-T

Example:

ICS XXXX y G - PPP - T

- Prefix: ICS, AV = Standard Device
- Device Type: XXXX
- Revision Designator: y (will not correlate with datasheet revision)
- Package Type: G=TSSOP
- Pattern Number (2 or 3 digit number for parts with ROM code patterns): PPP
- Designation for tape and reel packaging: T