

**Document Title**

256Kx16 bit Low Voltage and Ultra Low Power CMOS Static RAM

**Revision History**

<u>Revision No</u>	<u>History</u>	<u>Draft Date</u>	<u>Remark</u>
0A	Initial Draft	May 1,2001	Preliminary
0B	1. Change for $t_{PWE}$ : 45 to 40 ns for 55 ns product : 60 to 40 ns for 70 ns product 2. Change for $V_{CC}$ : 2.2-3.6V to 2.7-3.6V 3.1 Change for $I_{CC}$ test condition: $V_{CC} = \text{Max.}$ to 3V 3.2 Change for $I_{CC}$ : 35 to 40mA for 55 ns commercial product 30 to 35mA for 70 ns commercial product 25 to 30 mA for 100 ns commercial product 4. Change for $I_{SB1}$ test conditions: with $\overline{CE}$ controlled only 5.1 Change for $V_{DR}$ Min. : 1.2 to 1.5V 5.2 Change for $I_{DR}$ test condition: $V_{CC} = 1.2$ to 1.5V	August 21,2001	
0C	1.Change for $I_{CC}$ : 40 mA to 25 mA for 55 ns 35 mA to 20 mA for 70 ns 30 mA to 15mA for 100 ns 2.Change for $I_{DR}$ : 4 $\mu$ A to 5 $\mu$ A for commercial/LL product 6 $\mu$ A to 9 $\mu$ A for Industrial/LL Product	January 29,2002	
0D	Change for $V_{OH}$ : 2.0V to 2.4V	October 9,2002	

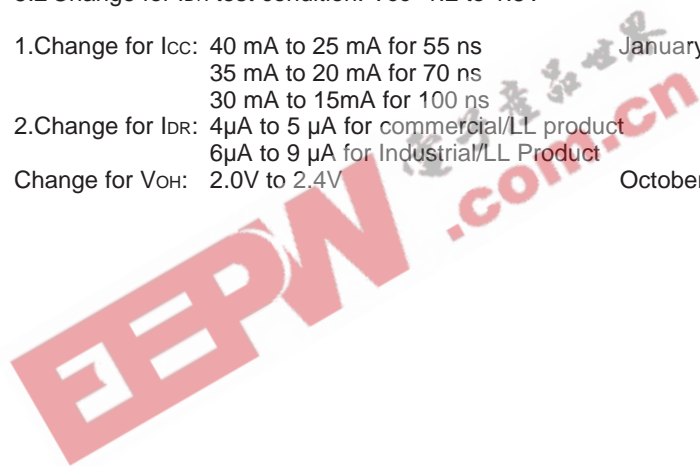

The attached datasheets are provided by ICSI. Integrated Circuit Solution Inc reserve the right to change the specifications and products. ICSI will answer to your questions about device. If you have any questions, please contact the ICSI offices.

## 256K x 16 LOW VOLTAGE, ULTRA LOW POWER CMOS STATIC RAM

### FEATURES

- High-speed access times: 55, 70, 100 ns
- CMOS low power operation
  - 60 mW (typical) operating
  - 3  $\mu$ W (typical) CMOS standby
- TTL compatible interface levels
- Single 2.7V-3.6V Vcc power supply
- Fully static operation: no clock or refresh required
- Three state outputs
- Data control for upper and lower bytes
- Industrial temperature available
- Available in the 44-pin TSOP-2 and 48-pin 6\*8mm TF-BGA

### DESCRIPTION

The *ICSI* IC62LV25616L and IC62LV25616LL are low-power, 4,194,304 bit static RAMs organized as 262,144 words by 16 bits. They are fabricated using *ICSI*'s high-performance CMOS technology. This highly reliable process coupled with innovative circuit design techniques, yields high-performance and low power consumption devices.

When  $\overline{CE}$  is HIGH (deselected) or both  $\overline{LB}$  and  $\overline{UB}$  are HIGH, the device assumes a standby mode at which the power dissipation can be reduced by using CMOS input levels.

Easy memory expansion is provided by using Chip Enable Output and Enable inputs,  $\overline{CE}$  and  $\overline{OE}$ . The active LOW Write Enable ( $\overline{WE}$ ) controls both writing and reading of the memory. A data byte allows Upper Byte ( $\overline{UB}$ ) and Lower Byte ( $\overline{LB}$ ) access.

The IC62LV25616L and IC62LV25616LL are packaged in the JEDEC standard 44-pin TSOP-2 and 48-pin 6\*8mm TF-BGA.

### FUNCTIONAL BLOCK DIAGRAM

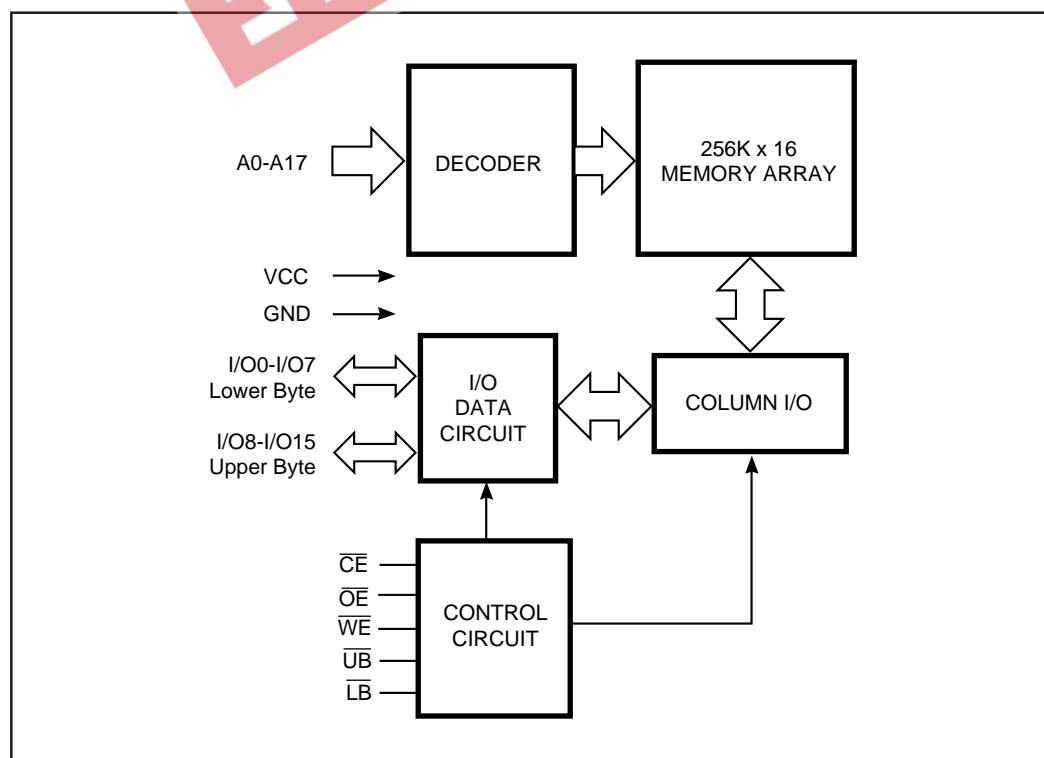

ICSI reserves the right to make changes to its products at any time without notice in order to improve design and supply the best possible product. We assume no responsibility for any errors which may appear in this publication. © Copyright 2001, Integrated Circuit Solution Inc.

**PIN CONFIGURATIONS**

**44-Pin TSOP-2**

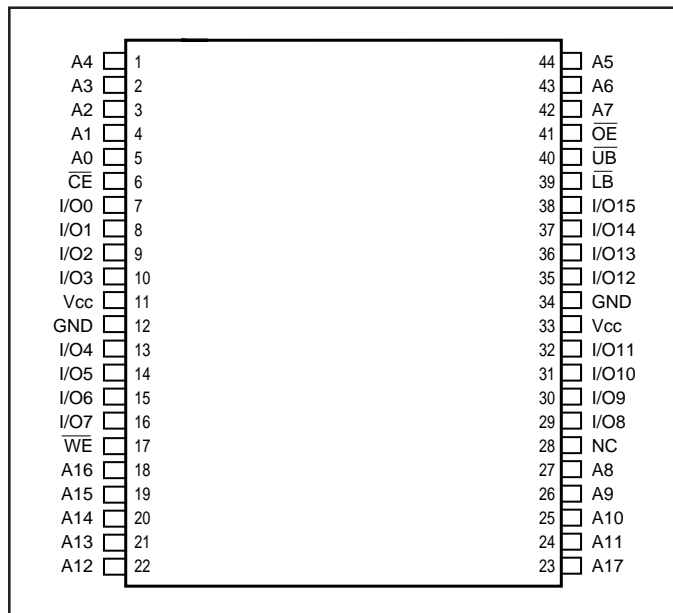

**48-Pin TF-BGA(TOP View)**

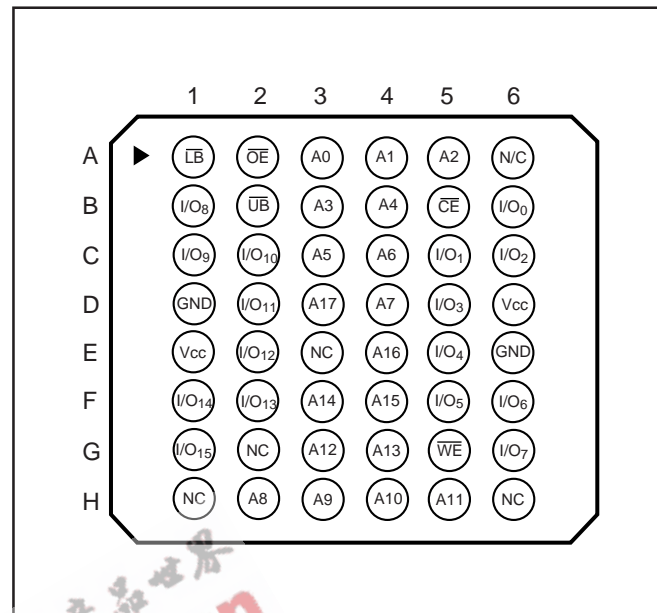

**PIN DESCRIPTIONS**

A0-A17	Address Inputs
I/O0-I/O15	Data Input/Output
$\overline{CE}$	Chip Enable Input
$\overline{OE}$	Output Enable Input
$\overline{WE}$	Write Enable Input

LB	Lower-byte Control (I/O0-I/O7)
UB	Upper-byte Control (I/O8-I/O15)
NC	No Connection
Vcc	Power
GND	Ground

**TRUTH TABLE**

Mode	I/O PIN					I/O0-I/O7	I/O8-I/O15	Power
	$\overline{WE}$	$\overline{CE}$	$\overline{OE}$	$\overline{LB}$	$\overline{UB}$			
Not Selected	X	H	X	X	X	High-Z	High-Z	Stand by
	X	L	X	H	H	High-Z	High-Z	Stand by
Output Disa&	X	High-Z		High-Z		Active		
	X	L	X	H	H	High-Z	High-Z	Stand by
Read	H	L	L	L	H	DOUT	High-Z	Active
	H	L	L	H	L	High-Z	DOUT	
	H	L	L	L	L	DOUT	DOUT	
Write	L	L	X	L	H	DIN	High-Z	Active
	L	L	X	H	L	High-Z	DIN	
	L	L	X	L	L	DIN	DIN	

## OPERATING RANGE

Range	Ambient Temperature	V <sub>CC</sub>
Commercial	0°C to +70°C	2.7V- 3.6V
Industrial	-40°C to +85°C	2.7V - 3.6V

## ABSOLUTE MAXIMUM RATINGS<sup>(1)</sup>

Symbol	Parameter	Value	Unit
V <sub>TERM</sub>	Terminal Voltage with Respect to GND	-0.5 to V <sub>CC</sub> + 0.5	V
T <sub>BIAS</sub>	Temperature Under Bias	-40 to +85	°C
V <sub>CC</sub>	V <sub>CC</sub> related to GND	-0.3 to +4.0	V
T <sub>STG</sub>	Storage Temperature	-65 to +150	°C
P <sub>T</sub>	Power Dissipation	1.0	W

### Notes:

1. Stress greater than those listed under ABSOLUTE MAXIMUM RATINGS may cause permanent damage to the device. This is a stress rating only and functional operation of the device at these or any other conditions above those indicated in the operational sections of this specification is not implied. Exposure to absolute maximum rating conditions for extended periods may affect reliability.

## DC ELECTRICAL CHARACTERISTICS (Over Operating Range)

Symbol	Parameter	Test Conditions	Min.	Max.	Unit
V <sub>OH</sub>	Output HIGH Voltage	I <sub>OH</sub> = -1 mA	2.4	—	V
V <sub>OL</sub>	Output LOW Voltage	I <sub>OL</sub> = 2.1 mA	—	0.4	V
V <sub>IH</sub> <sup>(1)</sup>	Input HIGH Voltage		2.2	V <sub>CC</sub> + 0.2	V
V <sub>IL</sub> <sup>(2)</sup>	Input LOW Voltage		-0.2	0.4	V
I <sub>LI</sub>	Input Leakage	GND ≤ V <sub>IN</sub> ≤ V <sub>CC</sub>	-1	1	μA
I <sub>LO</sub>	Output Leakage	GND ≤ V <sub>OUT</sub> ≤ V <sub>CC</sub> , OUTPUTS DISABLED	-1	1	μA

### Notes:

1. V<sub>IH</sub>(max.) = V<sub>CC</sub>+2.0V for pulse width less than 10 ns.
2. V<sub>IL</sub>(min.) = -2.0V for pulse width less than 10 ns.

## CAPACITANCE<sup>(1)</sup>

Symbol	Parameter	Conditions	Max.	Unit
C <sub>IN</sub>	Input Capacitance	V <sub>IN</sub> = 0V	6	pF
C <sub>OUT</sub>	Output Capacitance	V <sub>OUT</sub> = 0V	8	pF

### Notes:

1. Tested initially and after any design or process changes that may affect these parameters.

## AC TEST CONDITIONS

Parameter	Unit
Input Pulse Level	0.4V to 2.2V
Input Rise and Fall Times	5 ns
Input Reference Level	1.3V
Output Reference Level	1.5V
Output Load	See Figures 1

## AC TEST LOADS

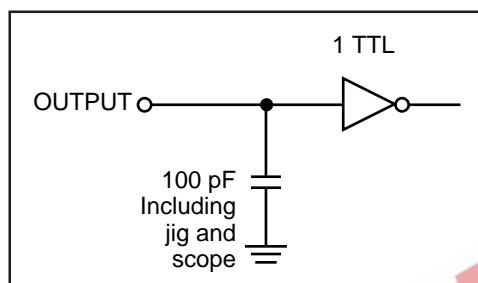

Figure 1

## IC62LV25616L POWER SUPPLY CHARACTERISTICS<sup>(1)</sup> (Over Operating Range)

Symbol	Parameter	Test Conditions	-55		-70		-100		Unit	
			Min.	Max.	Min.	Max.	Min.	Max.		
I <sub>CC</sub>	V <sub>CC</sub> Dynamic Operating Supply Current	V <sub>CC</sub> = 3V, I <sub>OUT</sub> = 0 mA, f = f <sub>MAX</sub>	Com.	—	25	—	20	—	15	mA
			Ind.	—	25	—	20	—	15	
I <sub>SB1</sub>	TTL Standby Current (TTL Inputs)	V <sub>CC</sub> = Max., V <sub>IN</sub> = V <sub>IH</sub> or V <sub>IL</sub> , CE ≥ V <sub>IH</sub> , f = 0	Com.	—	0.2	—	0.2	—	0.2	mA
			Ind.	—	0.3	—	0.3	—	0.3	
I <sub>SB2</sub>	CMOS Standby Current (CMOS Inputs)	V <sub>CC</sub> = Max., CE ≥ V <sub>CC</sub> - 0.2V, V <sub>IN</sub> ≥ V <sub>CC</sub> - 0.2V or V <sub>IN</sub> ≤ 0.2V, f = 0	Com.	—	35	—	35	—	35	μA
			Ind.	—	50	—	50	—	50	
<b>OR</b>										
	ULB Control	V <sub>CC</sub> = Max., V <sub>IN</sub> ≥ V <sub>CC</sub> - 0.2V or V <sub>IN</sub> ≤ 0.2V, f = 0, UB / LB ≥ V <sub>CC</sub> - 0.2V								

**Note:**

1. At f = f<sub>MAX</sub>, address and data inputs are cycling at the maximum frequency, f = 0 means no input lines change.

**IC62LV25616LL POWER SUPPLY CHARACTERISTICS<sup>(1)</sup> (Over Operating Range)**

Symbol	Parameter	Test Conditions		-55		-70		-100		Unit
				Min.	Max.	Min.	Max.	Min.	Max.	
I <sub>CC</sub>	V <sub>CC</sub> Dynamic Operating Supply Current	V <sub>CC</sub> = 3V, I <sub>OUT</sub> = 0 mA, f = f <sub>MAX</sub>	Com.	—	25	—	20	—	15	mA
			Ind.	—	25	—	20	—	15	
I <sub>SB1</sub>	TTL Standby Current (TTL Inputs)	V <sub>CC</sub> = Max., V <sub>IN</sub> = V <sub>IH</sub> or V <sub>IL</sub> , CE ≥ V <sub>IH</sub> , f = 0	Com.	—	0.2	—	0.2	—	0.2	mA
			Ind.	—	0.3	—	0.3	—	0.3	
I <sub>SB2</sub>	CMOS Standby Current (CMOS Inputs)	V <sub>CC</sub> = Max., f = 0 CE ≥ V <sub>CC</sub> - 0.2V, V <sub>IN</sub> ≥ V <sub>CC</sub> - 0.2V or V <sub>IN</sub> ≤ 0.2V, f = 0	Com.	—	15	—	15	—	15	μA
			Ind.	—	20	—	20	—	20	
<b>OR</b>										
	ULB Control	V <sub>CC</sub> = Max., V <sub>IN</sub> ≥ V <sub>CC</sub> - 0.2V or V <sub>IN</sub> ≤ 0.2V, f = 0, UB / LB ≥ V <sub>CC</sub> - 0.2V								

**Note:**

1. At f = f<sub>MAX</sub>, address and data inputs are cycling at the maximum frequency, f = 0 means no input lines change.

**READ CYCLE SWITCHING CHARACTERISTICS<sup>(1)</sup> (Over Operating Range)**

Symbol	Parameter	-55		-70		-100		Unit
		Min.	Max.	Min.	Max.	Min.	Max.	
t <sub>RC</sub>	Read Cycle Time	55	—	70	—	100	—	ns
t <sub>AA</sub>	Address Access Time	—	55	—	70	—	100	ns
t <sub>OHA</sub>	Output Hold Time	10	—	10	—	15	—	ns
t <sub>ACE</sub>	CE Access Time	—	55	—	70	—	100	ns
t <sub>DOE</sub>	OE Access Time	—	30	—	38	—	50	ns
t <sub>HZOE<sup>(2)</sup></sub>	OE to High-Z Output	—	20	—	25	—	30	ns
t <sub>LZOE<sup>(2)</sup></sub>	OE to Low-Z Output	5	—	5	—	5	—	ns
t <sub>HZCE<sup>(2)</sup></sub>	CE to High-Z Output	0	20	0	25	0	30	ns
t <sub>LZCE<sup>(2)</sup></sub>	CE to Low-Z Output	10	—	10	—	10	—	ns
t <sub>BA</sub>	LB, UB Access Time	—	55	—	70	—	100	ns
t <sub>HZB</sub>	LB, UB to High-Z Output	0	25	0	25	0	35	ns
t <sub>LZB</sub>	LB, UB to Low-Z Output	0	—	0	—	0	—	ns

**Notes:**

1. Test conditions assume signal transition times of 5 ns or less, input pulse levels of 0.4V to 2.2V and output loading specified in Figure 1.
2. Tested with the load in Figure 2. Transition is measured ±500 mV from steady-state voltage. Not 100% tested.

## AC TEST LOADS

### READ CYCLE NO. 1<sup>(1,2)</sup> (Address Controlled) ( $\overline{CE} = \overline{OE} = V_{IL}$ , $\overline{UB}$ or $\overline{LB} = V_{IL}$ )

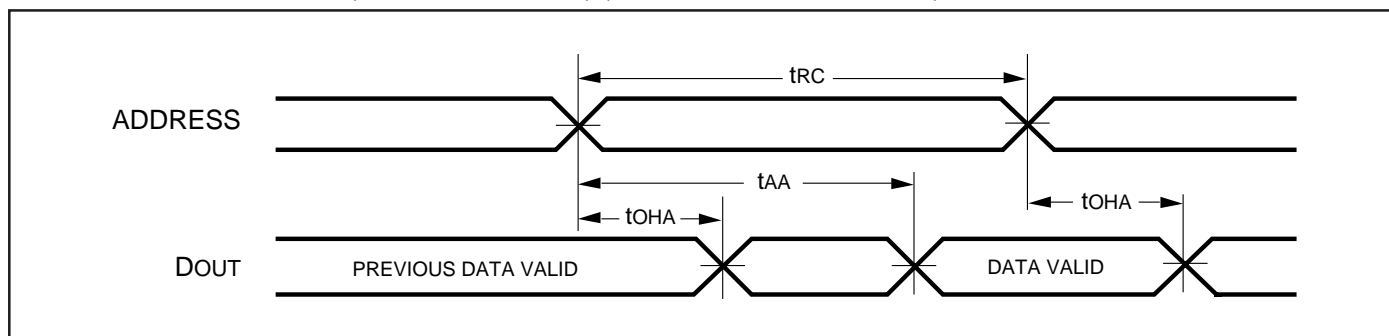

## AC WAVEFORMS

### READ CYCLE NO. 2<sup>(1,3)</sup> ( $\overline{CE}$ , $\overline{OE}$ , AND $\overline{UB}/\overline{LB}$ Controlled)

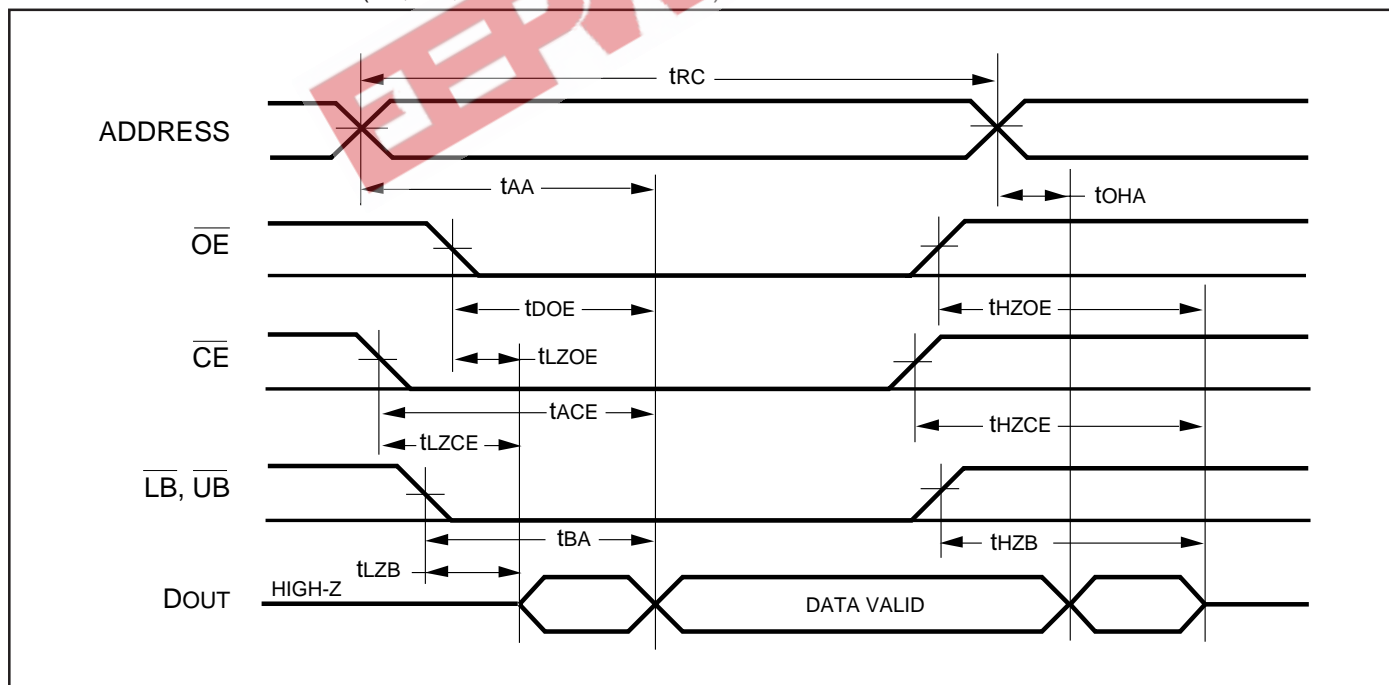

**Notes:**

1.  $\overline{WE}$  is HIGH for a Read Cycle.
2. The device is continuously selected.  $\overline{OE}$ ,  $\overline{CE}$ ,  $\overline{UB}$ , or  $\overline{LB} = V_{IL}$ .
3. Address is valid prior to or coincident with  $\overline{CE}$  LOW transitions.

**WRITE CYCLE SWITCHING CHARACTERISTICS<sup>(1,2)</sup>** (Over Operating Range)

Symbol	Parameter	-55		-70		-100		Unit
		Min.	Max.	Min.	Max.	Min.	Max.	
t <sub>WC</sub>	Write Cycle Time	55	—	70	—	100	—	ns
t <sub>SCE</sub>	$\overline{CE}$ to Write End	50	—	65	—	80	—	ns
t <sub>AW</sub>	Address Setup Time to Write End	50	—	65	—	80	—	ns
t <sub>HA</sub>	Address Hold from Write End	0	—	0	—	0	—	ns
t <sub>SA</sub>	Address Setup Time	0	—	0	—	0	—	ns
t <sub>PWB</sub>	$\overline{LB}$ , $\overline{UB}$ Valid to End of Write	45	—	60	—	80	—	ns
t <sub>PWE</sub>	$\overline{WE}$ Pulse Width	40	—	40	—	80	—	ns
t <sub>SD</sub>	Data Setup to Write End	25	—	30	—	40	—	ns
t <sub>HD</sub>	Data Hold from Write End	0	—	0	—	0	—	ns
t <sub>HZWE<sup>(3)</sup></sub>	$\overline{WE}$ LOW to High-Z Output	—	30	—	30	—	40	ns
t <sub>LZWE<sup>(3)</sup></sub>	$\overline{WE}$ HIGH to Low-Z Output	5	—	5	—	5	—	ns

**Notes:**

1. Test conditions assume signal transition times of 5 ns or less, input pulse levels of 0.4V to 2.2V and output loading specified in Figure 1.
2. The internal write time is defined by the overlap of  $\overline{CE}$  LOW, and  $\overline{UB}$  or  $\overline{LB}$ , and  $\overline{WE}$  LOW. All signals must be in valid states to initiate a Write, but any one can go inactive to terminate the Write. The Data Input Setup and Hold timing are referenced to the rising or falling edge of the signal that terminates the Write.
3. Tested with the load in Figure 2. Transition is measured  $\pm 500$  mV from steady-state voltage. Not 100% tested.

**AC WAVEFORMS**

**WRITE CYCLE NO. 1<sup>(1,2)</sup>** ( $\overline{CE}$  Controlled)

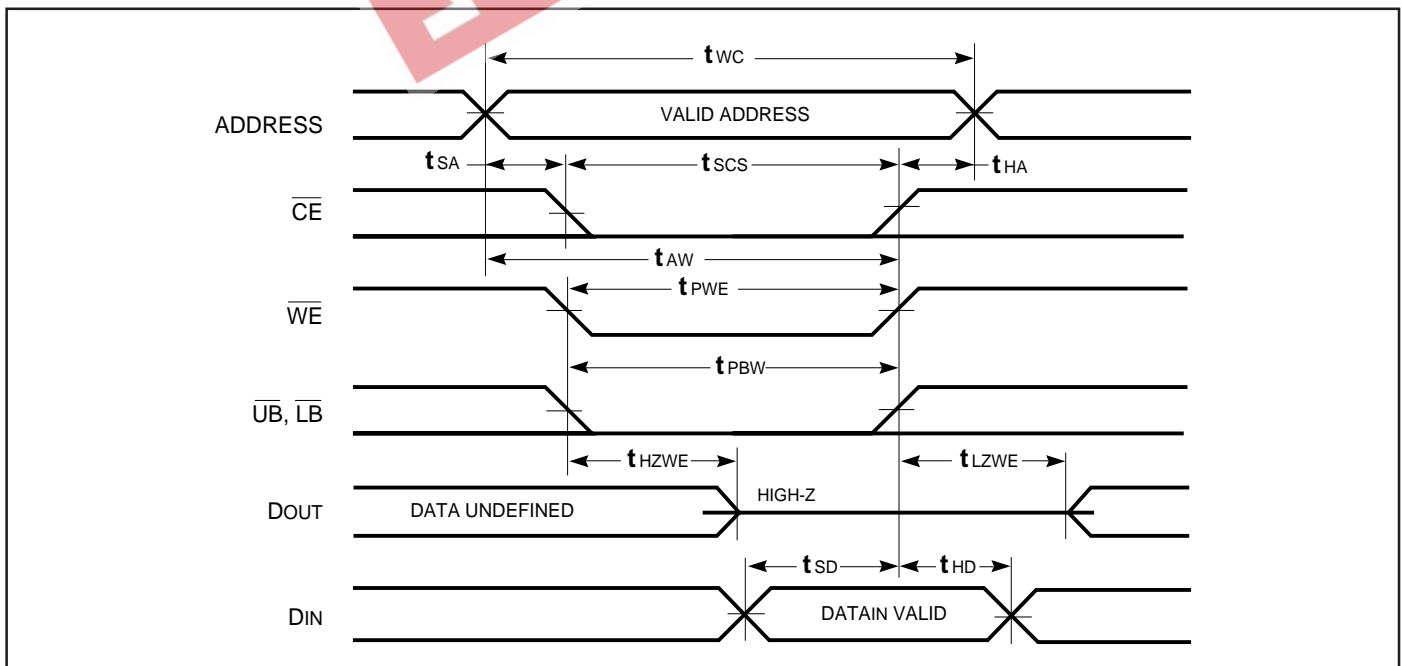

**Notes:**

1. WRITE is an internally generated signal asserted during an overlap of the LOW states on the  $\overline{CE}$  and  $\overline{WE}$  inputs and at least one of the  $\overline{LB}$  and  $\overline{UB}$  inputs being in the LOW state.
2. WRITE = ( $\overline{CE}$ ) [ ( $\overline{LB}$ ) = ( $\overline{UB}$ ) ] ( $\overline{WE}$ ).



WRITE CYCLE NO. 2 ( $\overline{WE}$  Controlled)

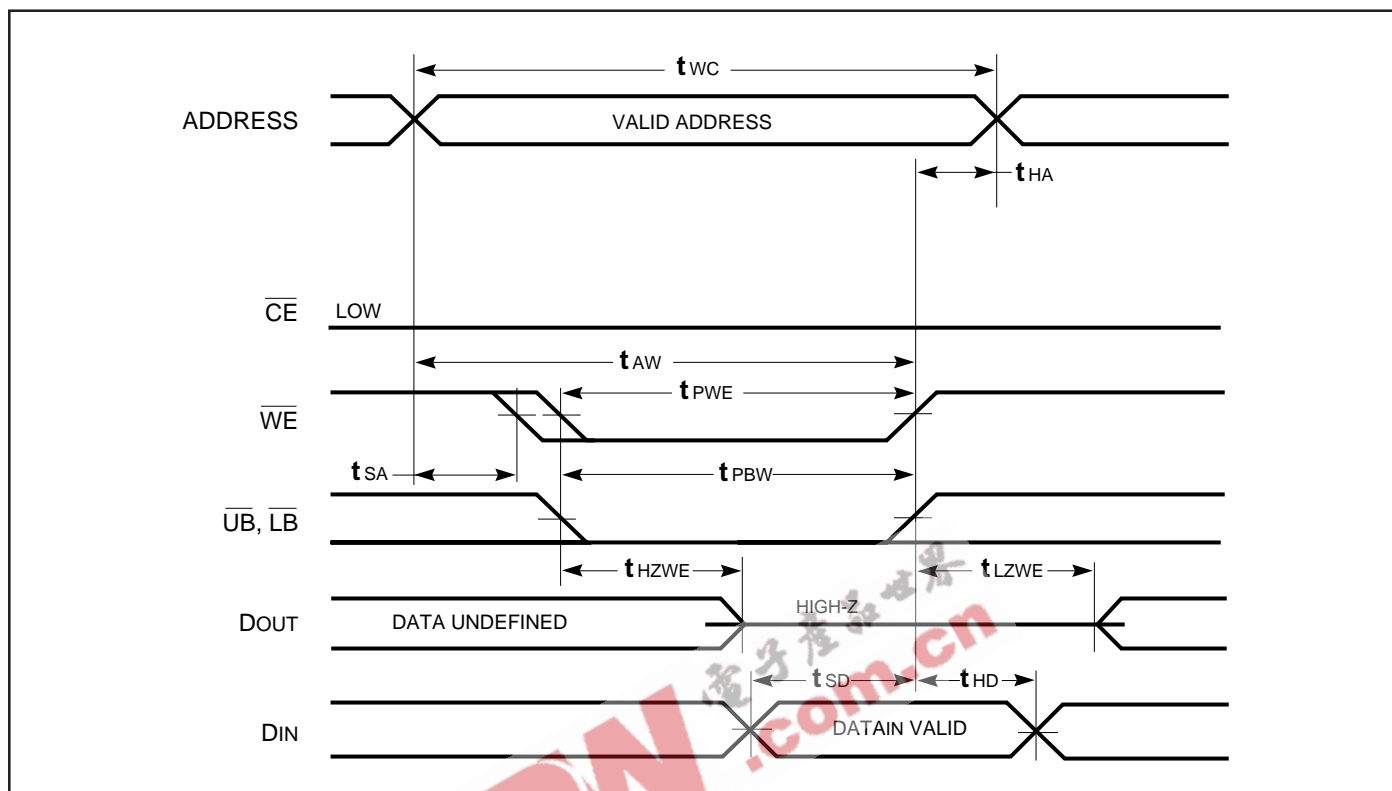

WRITE CYCLE NO. 3 ( $\overline{UB}$  /  $\overline{LB}$  Controlled)

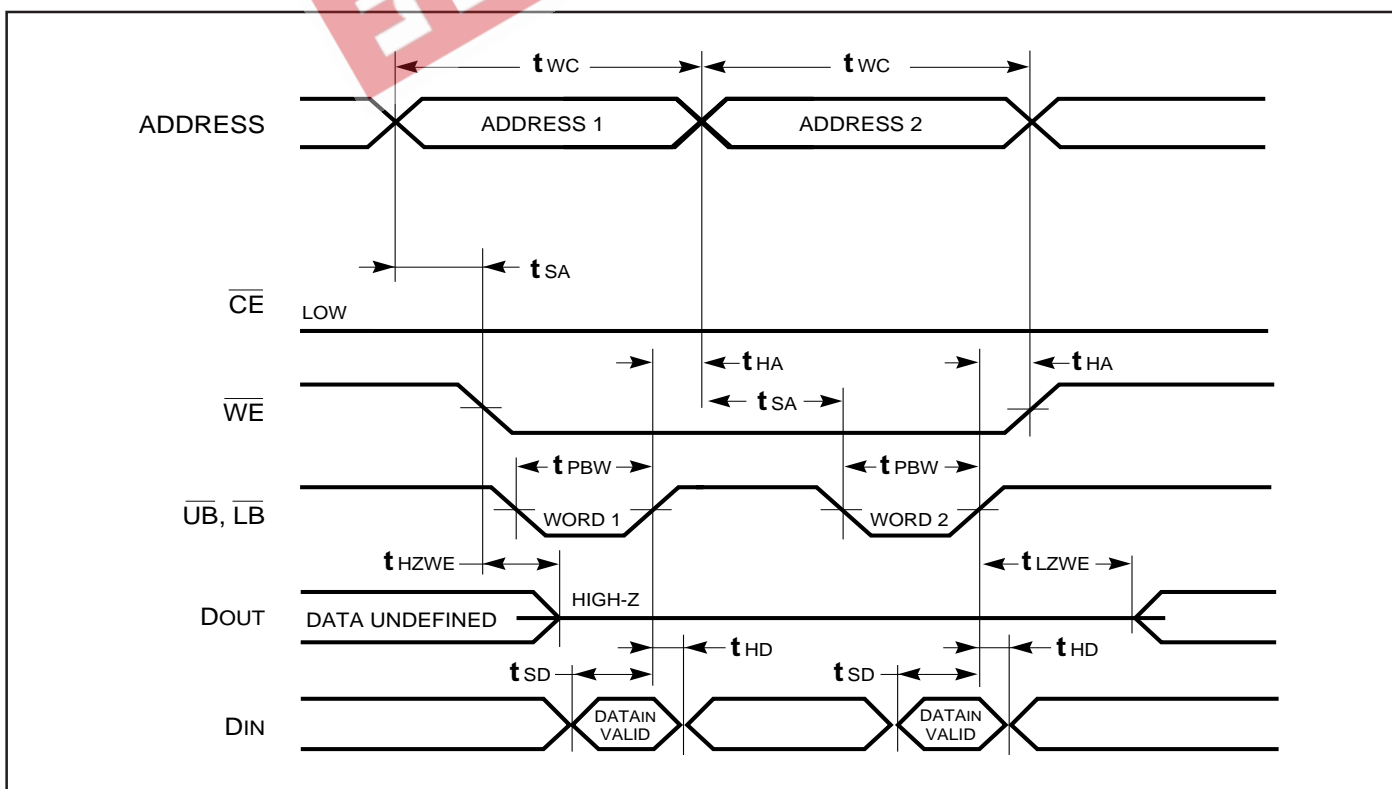

## DATA RETENTION SWITCHING CHARACTERISTICS

Symbol	Parameter	TestCondition	Min.	Max.	Unit
$V_{DR}$	Vcc for Data Retention	See Data Retention Waveform	1.5	3.6	V
$I_{DR}$	Data Retention Current	$V_{CC} = 1.5V, \overline{CE} \geq V_{CC} - 0.2V$	Com. (-L) Com. (-LL) Ind. (-L) Ind. (-LL)	— 10 5 15 9	$\mu A$
$t_{SDR}$	Data Retention Setup Time	See Data Retention Waveform	0	—	ns
$t_{RDR}$	Recovery Time	See Data Retention Waveform	5	—	ns

### DATA RETENTION WAVEFORM ( $\overline{CE}$ or LB/UB Controlled)

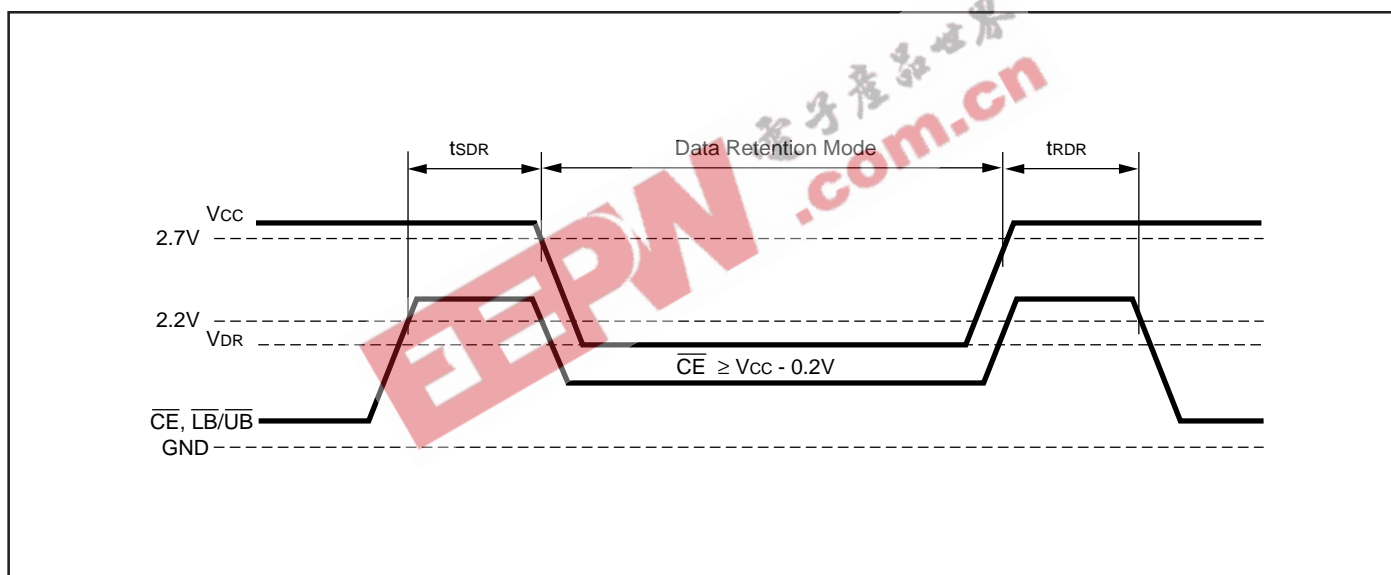

**ORDERING INFORMATION**

**Commercial Range: 0°C to +70°C**

Speed (ns)	Order Part No.	Package
55	IC62LV25616L-55T	TSOP-2
	IC62LV25616L-55B	6*8mm TF-BGA
70	IC62LV25616L-70T	TSOP-2
	IC62LV25616L-70B	6*8mm TF-BGA
100	IC62LV25616L-100T	TSOP-2
	IC62LV25616L-100B	6*8mm TF-BGA

**Industrial Range: -40°C to +85°C**

Speed (ns)	Order Part No.	Package
55	IC62LV25616L-55TI	TSOP-2
	IC62LV25616L-55BI	6*8mm TF-BGA
70	IC62LV25616L-70TI	TSOP-2
	IC62LV25616L-70BI	6*8mm TF-BGA
100	IC62LV25616L-100TI	TSOP-2
	IC62LV25616L-100BI	6*8mm TF-BGA

**ORDERING INFORMATION**

**Commercial Range: 0°C to +70°C**

Speed (ns)	Order Part No.	Package
55	IC62LV25616LL-55T	TSOP-2
	IC62LV25616LL-55B	6*8mm TF-BGA
70	IC62LV25616LL-70T	TSOP-2
	IC62LV25616LL-70B	6*8mm TF-BGA
100	IC62LV25616LL-100T	TSOP-2
	IC62LV25616LL-100B	6*8mm TF-BGA

**Industrial Range: -40°C to +85°C**

Speed (ns)	Order Part No.	Package
55	IC62LV25616LL-55TI	TSOP-2
	IC62LV25616LL-55BI	6*8mm TF-BGA
70	IC62LV25616LL-70TI	TSOP-2
	IC62LV25616LL-70BI	6*8mm TF-BGA
100	IC62LV25616LL-100TI	TSOP-2
	IC62LV25616LL-100BI	6*8mm TF-BGA



***Integrated Circuit Solution Inc.***

HEADQUARTER:  
NO.2, TECHNOLOGY RD. V, SCIENCE-BASED INDUSTRIAL PARK,  
HSIN-CHU, TAIWAN, R.O.C.  
TEL: 886-3-5780333  
Fax: 886-3-5783000

BRANCH OFFICE:  
7F, NO. 106, SEC. 1, HSIN-TAI 5<sup>TH</sup> ROAD,  
HSICHIH TAIPEI COUNTY, TAIWAN, R.O.C.  
TEL: 886-2-26962140  
FAX: 886-2-26962252  
<http://www.icsi.com.tw>