

November 1996

Long Range Fixed Timer

Features

- Replaces the 2242 in Most Applications
- Timing From Microseconds to Days
- Cascadable
- Monostable or Astable Operation
- Wide Supply Voltage Range2V to 16V
- Low Supply Current.....115 μ A at 5V

Ordering Information

PART NUMBER (BRAND)	TEMP. RANGE (°C)	PACKAGE	PKG. NO.
ICM7242IPA	-25 to 85	8 Ld PDIP	E8.3
ICM7242CBA (7242CBA)	0 to 70	8 Ld SOIC	M8.15

Description

The ICM7242 is a CMOS timer/counter circuit consisting of an RC oscillator followed by an 8-bit binary counter. It will replace the 2242 in most applications, with a significant reduction in the number of external components.

Three outputs are provided. They are the oscillator output, and buffered outputs from the first and eighth counters.

Pinout

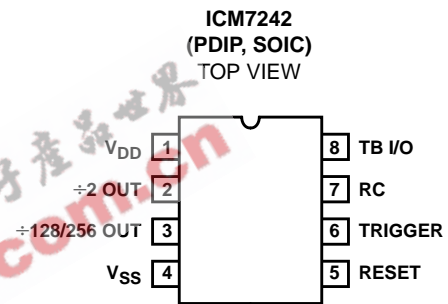

Functional Diagram

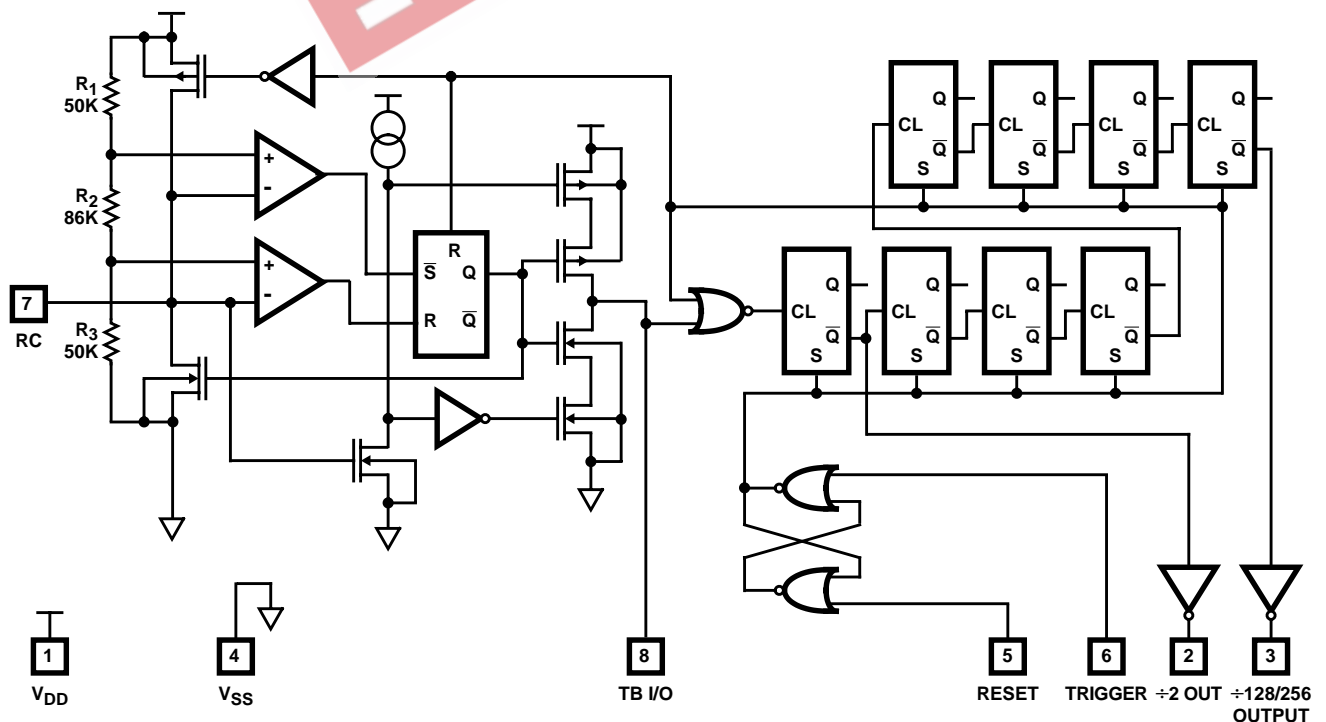

ICM7242

Absolute Maximum Ratings

Supply Voltage (V_{DD} to V_{SS})	18V
Input Voltage (Note 1)	
Terminals (Pins 5, 6, 7, 8)	($V_{SS} - 0.3V$) to ($V_{DD} + 0.3V$)
Continuous Output Current (Each Output)	50mA

Operating Conditions

Temperature Range	
ICM7242I	-25°C to 85°C
ICM7242C	0°C to 70°C

Thermal Information

Thermal Resistance (Typical, Note 2)	θ_{JA} (°C/W)
PDIP Package	100
SOIC Package	160
Maximum Storage Temperature Range	-65°C to 150°C
Maximum Junction Temperature (Plastic Package)	150°C
Maximum Lead Temperature (Soldering 10s)	300°C (SOIC - Lead Tips Only)

CAUTION: Stresses above those listed in "Absolute Maximum Ratings" may cause permanent damage to the device. This is a stress only rating and operation of the device at these or any other conditions above those indicated in the operational sections of this specification is not implied.

NOTES:

- Due to the SCR structure inherent in the CMOS process, connecting any terminal to voltages greater than V_{DD} or less than V_{SS} may cause destructive device latchup. For this reason, it is recommended that no inputs from external sources not operating on the same supply be applied to the device before its supply is established and, that in multiple supply systems, the supply to the ICM7242 be turned on first.
- θ_{JA} is measured with the component mounted on an evaluation PC board in free air.

Electrical Specifications $V_{DD} = 5V$, $T_A = 25^\circ C$, $R = 10k\Omega$, $C = 0.1\mu F$, $V_{SS} = 0V$, Unless Otherwise Specified

PARAMETER	SYMBOL	TEST CONDITIONS	MIN	TYP	MAX	UNITS	
Guaranteed Supply Voltage	V_{DD}		2	-	16	V	
Supply Current	I_{DD}	Reset	-	125	-	μA	
		Operating, $R = 10k\Omega$, $C = 0.1\mu F$	-	340	800	μA	
		Operating, $R = 1M\Omega$, $C = 0.1\mu F$	-	220	600	μA	
		TB Inhibited, RC Connected to V_{SS}	-	225	-	μA	
Timing Accuracy			-	5	-	%	
RC Oscillator Frequency Temperature Drift	$\Delta f/\Delta t$	Independent of RC Components	-	250	-	ppm/°C	
Time Base Output Voltage	V_{OTB}	$I_{SOURCE} = 100\mu A$	-	3.5	-	V	
		$I_{SINK} = 1.0mA$	-	0.40	-	V	
Time Base Output Leakage Current	I_{TBLK}	RC = Ground	-	-	25	μA	
Trigger Input Voltage	V_{TRIG}	$V_{DD} = 5V$	-	1.6	2.0	V	
		$V_{DD} = 15V$	-	3.5	4.5	V	
Reset Input Voltage	V_{RST}	$V_{DD} = 5V$	-	1.3	2.0	V	
		$V_{DD} = 15V$	-	2.7	4.0	V	
Trigger/Reset Input Current	I_{TRIG}, I_{RST}		-	10	-	μA	
Max Count Toggle Rate	f_T	$V_{DD} = 2V$ $V_{DD} = 5V$ $V_{DD} = 15V$	Counter/Divider Mode	-	1	-	MHz
				2	6	-	MHz
				-	13	-	MHz
		50% Duty Cycle Input with Peak to Peak Voltages Equal to V_{DD} and V_{SS}					
Output Saturation Voltage	V_{SAT}	All Outputs Except TB Output $V_{DD} = 5V$, $I_{OUT} = 3.2mA$	-	0.22	0.4	V	
Output Sourcing Current	I_{SOURCE}	$V_{DD} = 5V$ Terminals 2 and 3, $V_{OUT} = 1V$	-	300	-	μA	
MIN Timing Capacitor (Note 3)	C_T		10	-	-	pF	
Timing Resistor Range (Note 3)	R_T	$V_{DD} = 2 - 16V$	1K	-	22M	Ω	

NOTE:

- For design only, not tested.

ICM7242

Test Circuit

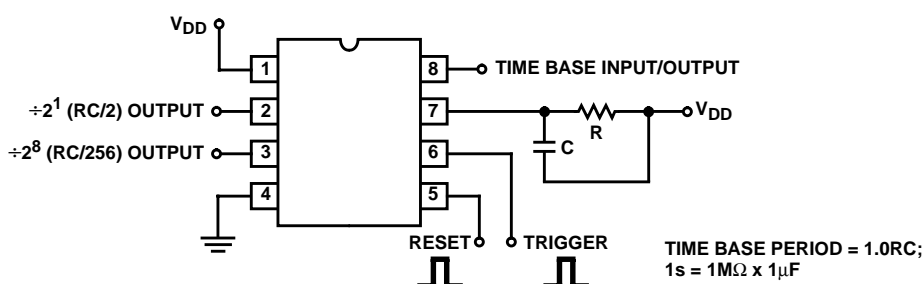

NOTE:

4. $\div 2^1$ and $\div 2^8$ outputs are inverters and have active pullups.

Application Information

Operating Considerations

Shorting the RC terminal or output terminals to V_{DD} may exceed dissipation ratings and/or maximum DC current limits (especially at high supply voltages).

There is a limitation of 50pF maximum loading on the TB I/O terminal if the timebase is being used to drive the counter section. If higher value loading is used, the counter sections may miscount.

For greatest accuracy, use timing component values shown in Figure 8. For highest frequency operation it will be desirable to use very low values for the capacitor; accuracy will decrease for oscillator frequencies in excess of 200kHz.

The timing capacitor should be connected between the RC pin and the positive supply rail, V_{DD} , as shown in Figure 1. When system power is turned off, any charge remaining on the capacitor will be discharged to ground through a large internal diode between the RC node and V_{SS} . Do NOT reference the timing capacitor to ground, since there is no high current path in this direction to safely discharge the capacitor when power is turned off. The discharge current from such a configuration could potentially damage the device.

When driving the counter section from an external clock, the optimum drive waveform is a square wave with an amplitude equal to the supply voltage. If the clock is a very slow ramp triangular, sine wave, etc., it will be necessary to "square up" the waveform; this can be done by using two CMOS inverters in series, operating from the same supply voltage as the ICM7242.

The ICM7242 is a non-programmable timer whose principal applications will be very low frequency oscillators and long range timers; it makes a much better low frequency oscillator/timer than a 555 or ICM7555, because of the on-chip 8-bit counter. Also, devices can be cascaded to produce extremely low frequency signals.

Because outputs will not be ANDed, output inverters are used instead of open drain N-Channel transistors, and the external resistors used for the 2242 will not be required for the ICM7242. The ICM7242 will, however, plug into a socket for the 2242 having these resistors.

The timing diagram for the ICM7242 is shown in Figure 1. Assuming that the device is in the RESET mode, which occurs on power up or after a positive signal on the RESET terminal (if TRIGGER is low), a positive edge on the trigger input signal will initiate normal operation. The discharge transistor turns on, discharging the timing capacitor C, and all the flip-flops in the counter chain change states. Thus, the outputs on terminals 2 and 3 change from high to low states. After 128 negative timebase edges, the $\div 2^8$ output returns to the high state.

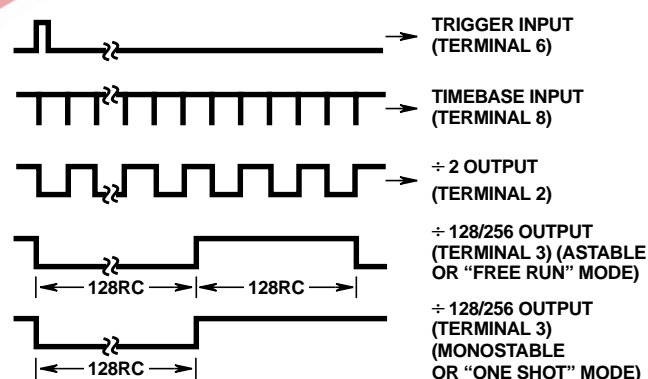

FIGURE 1. TIMING DIAGRAMS OF OUTPUT WAVEFORMS FOR THE ICM7242 (COMPARE WITH FIGURE 5)

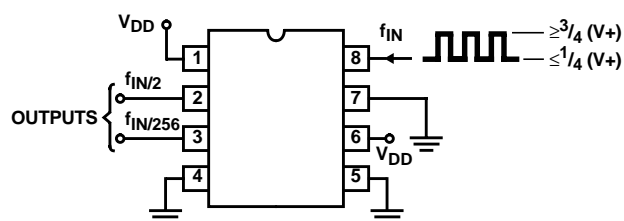

FIGURE 2. USING THE ICM7242 AS A RIPPLE COUNTER (DIVIDER)

ICM7242

To use the 8-bit counter without the timebase, Terminal 7 (RC) should be connected to ground and the outputs taken from Terminals 2 and 3.

The ICM7242 may be used for a very low frequency square wave reference. For this application the timing components are more convenient than those that would be required by a 555 timer. For very low frequencies, devices may be cascaded (see Figure 3).

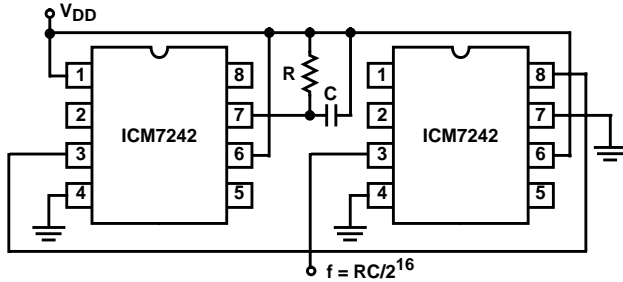

FIGURE 3. LOW FREQUENCY REFERENCE (OSCILLATOR)

For monostable operation the $\div 2^8$ output is connected to the RESET terminal. A positive edge on TRIGGER initiates the cycle (NOTE: TRIGGER overrides RESET).

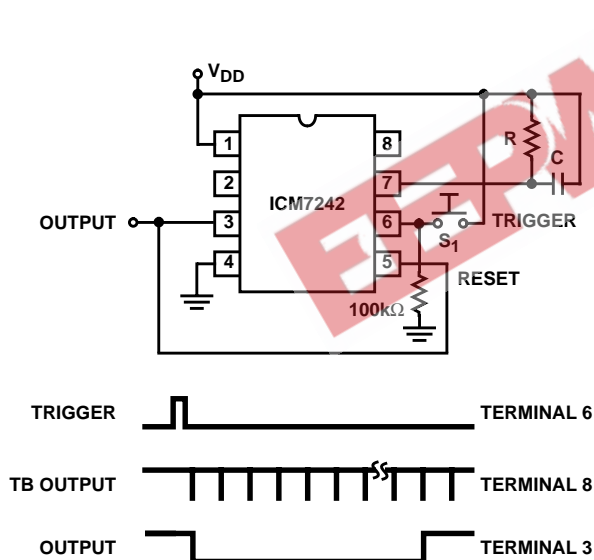

FIGURE 4. MONOSTABLE OPERATION

The ICM7242 is superior in all respects to the 2242 except for initial accuracy and oscillator stability. This is primarily due to the fact that high value p- resistors have been used on the ICM7242 to provide the comparator timing points.

Comparing the ICM7242 With the 2242

	ICM7242	2242
Operating Voltage	2V - 16V	4V - 15V
Operating Temperature Range	-25°C to 85°C	0°C to 70°C
Supply Current, $V_{DD} = 5V$	0.7mA (Max)	7mA (Max)
Pullup Resistors		
TB Output	No	Yes
$\div 2$ Output	No	Yes
$\div 256$ Output	No	Yes
Toggle Rate	3.0MHz	0.5MHz
Resistor to Inhibit Oscillator	No	Yes
Resistor in Series with Reset for Monostable Operation	No	Yes
Capacitor TB Terminal for HF Operation	No	Sometimes

By selection of R and C, a wide variety of sequence timing can be realized. A typical flow chart for a machine tool controller could be as shown in Figure 5.

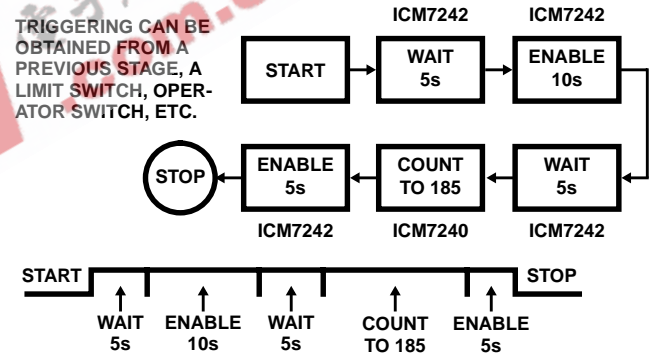

FIGURE 5. FLOW CHART FOR MACHINE TOOL CONTROLLER

By cascading devices, use of low cost CMOS AND/OR gates and appropriate RC delays between stages, numerous sequential control variations can be obtained. Typical applications include injection molding machine controllers, phonograph record production machines, automatic sequencers (no metal contacts or moving parts), milling machine controllers, process timers, automatic lubrication systems, etc.

Sequence Timing

- Process Control
- Machine Automation
- Electro-Pneumatic Drivers
- Multi Operation (Serial or Parallel Controlling)

ICM7242

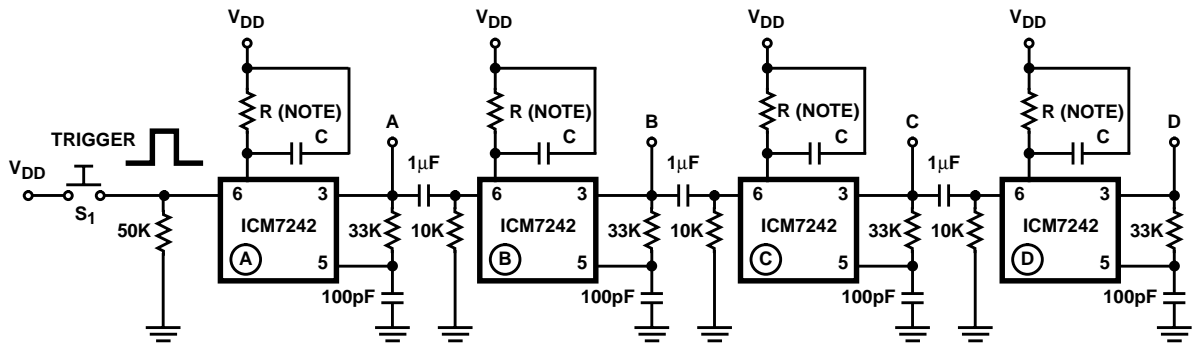

PUSH S_1 TO START SEQUENCE:

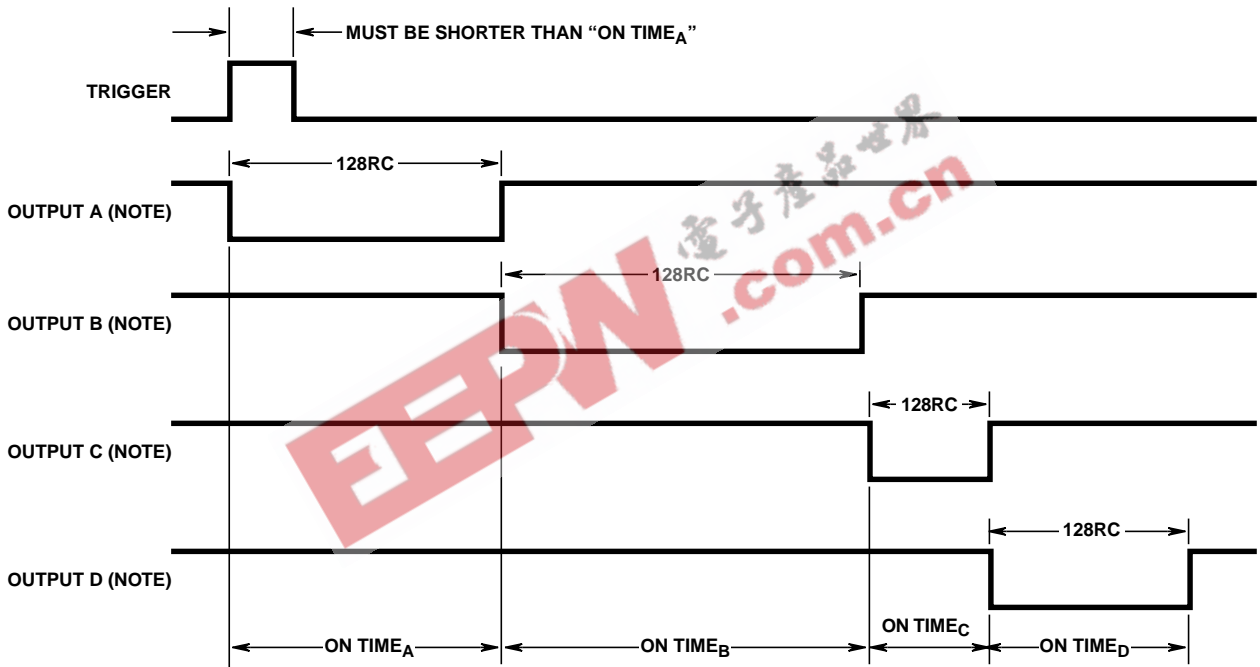

NOTE: Select RC values for desired "ON TIME" for each ICM7242.

FIGURE 6. SEQUENCE TIMER

Typical Performance Curves

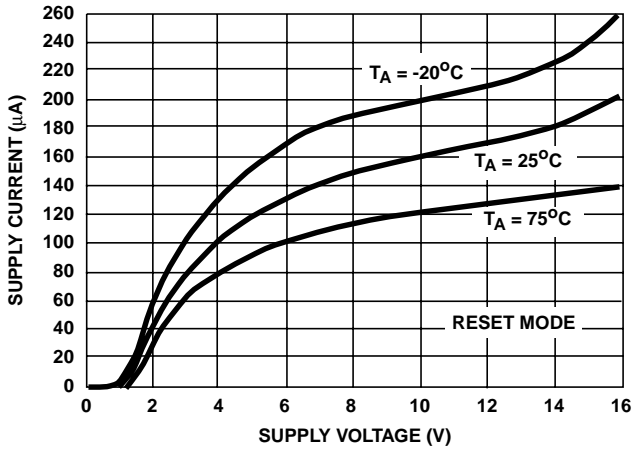

FIGURE 7. SUPPLY CURRENT vs SUPPLY VOLTAGE

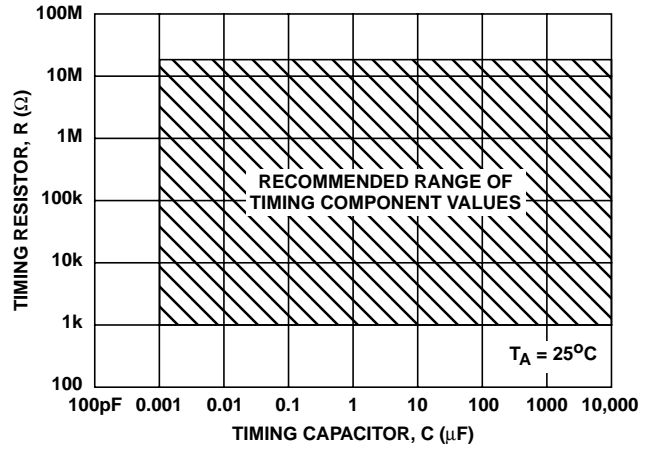

FIGURE 8. RECOMMENDED RANGE OF TIMING COMPONENT VALUES FOR ACCURATE TIMING

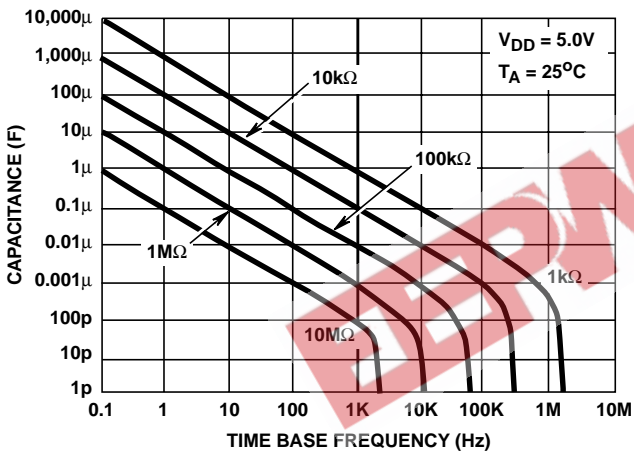

FIGURE 9. TIMEBASE FREE RUNNING FREQUENCY vs R AND C

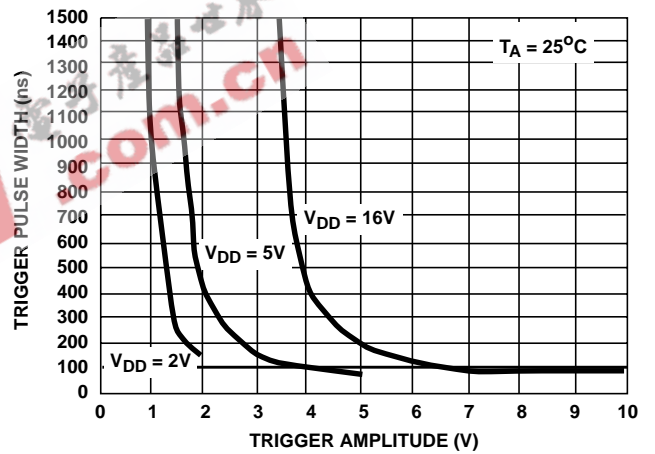

FIGURE 10. MINIMUM TRIGGER PULSE WIDTH vs TRIGGER AMPLITUDE

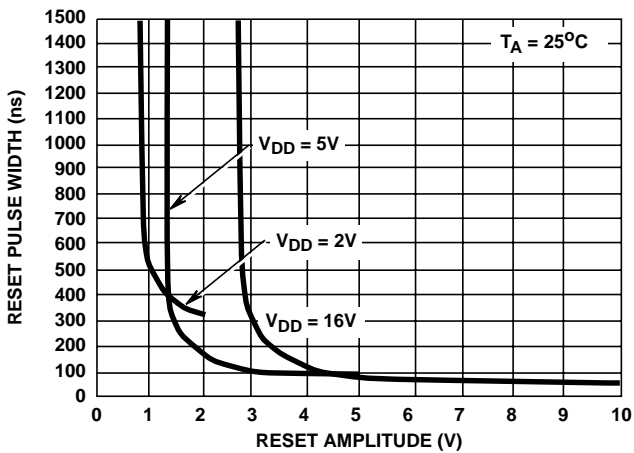

FIGURE 11. MINIMUM RESET PULSE WIDTH vs RESET AMPLITUDE

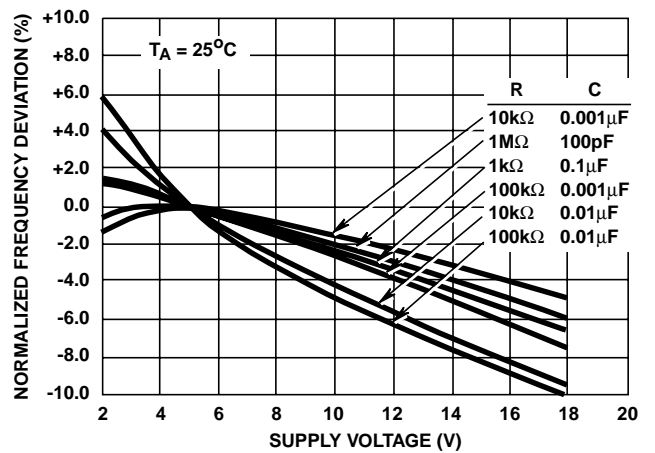

FIGURE 12. NORMALIZED FREQUENCY STABILITY IN THE ASTABLE MODE vs SUPPLY VOLTAGE

ICM7242

Typical Performance Curves (Continued)

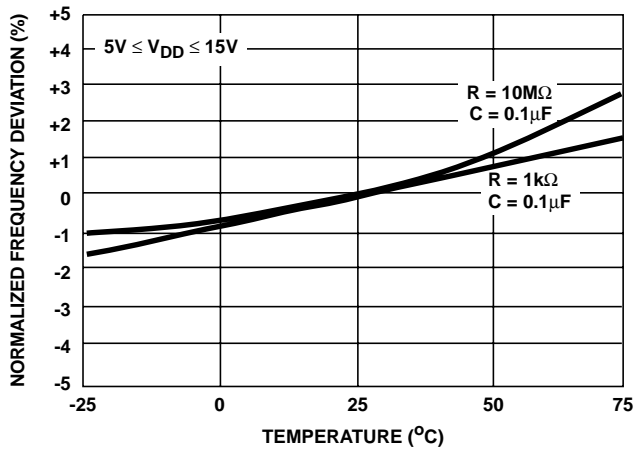

FIGURE 13. NORMALIZED FREQUENCY STABILITY IN THE ASTABLE MODE vs TEMPERATURE

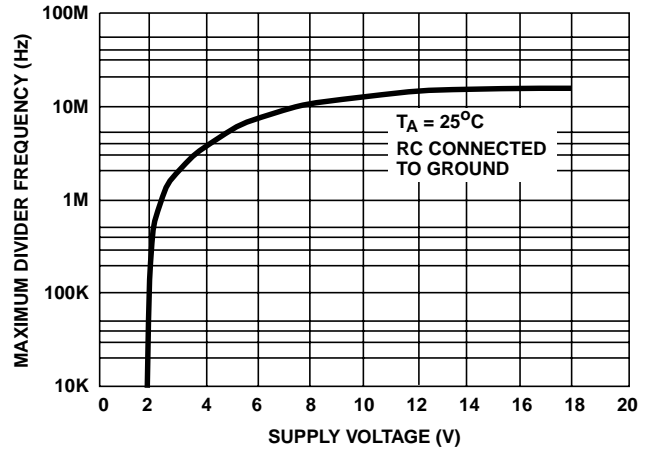

FIGURE 14. MAXIMUM DIVIDER FREQUENCY vs SUPPLY VOLTAGE

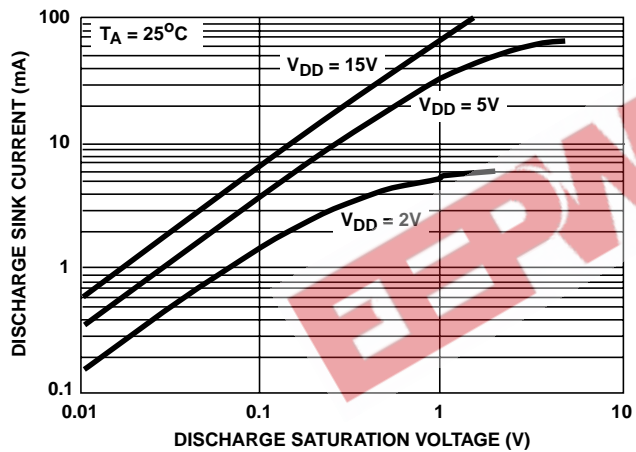

FIGURE 15. DISCHARGE OUTPUT CURRENT vs DISCHARGE OUTPUT VOLTAGE

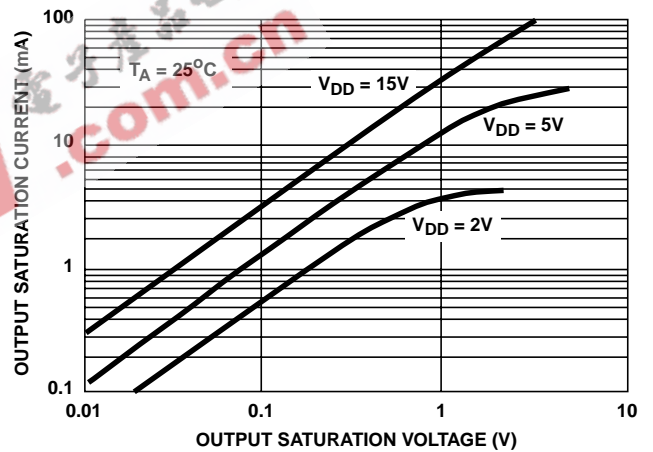

FIGURE 16. OUTPUT SATURATION CURRENT vs OUTPUT SATURATION VOLTAGE