



IC41C4105 and IC41LV4105

Document Title

1Mx4 bit Dynamic RAM with Fast Page Mode

Revision History

<u>Revision No</u>	<u>History</u>	<u>Draft Date</u>	<u>Remark</u>
0A	Initial Draft	August 1,2001	

EEPW 电子產品世界
.com.cn

The attached datasheets are provided by ICSI. Integrated Circuit Solution Inc reserve the right to change the specifications and products. ICSI will answer to your questions about device. If you have any questions, please contact the ICSI offices.

1M x 4 (4-MBIT) DYNAMIC RAM WITH FAST PAGE MODE

FEATURES

- Fast Page Mode Access Cycle
- TTL compatible inputs and outputs
- Refresh Interval:
-- 1,024 cycles/16 ms
- Refresh Mode: $\overline{\text{RAS}}$ -Only, CAS-before-RAS (CBR), and Hidden
- JEDEC standard pinout
- Single power supply:
5V \pm 10% or 3.3V \pm 10%
- Byte Write and Byte Read operation via two CAS

DESCRIPTION

The *ICSI* 4105 Series is a 1,048,576 x 4-bit high-performance CMOS Dynamic Random Access Memory. The Fast Page Mode allows 1,024 random accesses within a single row with access cycle time as short as 12 ns per 4-bit word.

These features make the 4105 Series ideally suited for high-bandwidth graphics, digital signal processing, high-performance computing systems, and peripheral applications.

The 4105 Series is packaged in a 20-pin 300mil SOJ and a 20 pin TSOP-2

PRODUCT SERIES OVERVIEW

Part No.	Refresh	Voltage
IC41C4105	1K	5V \pm 10%
IC41LV4105	1K	3.3V \pm 10%

KEY TIMING PARAMETERS

Parameter	-35	-50	-60	Unit
RAS Access Time (t _{RAC})	35	50	60	ns
CAS Access Time (t _{CAC})	10	14	15	ns
Column Address Access Time (t _{AA})	18	25	30	ns
Fast Page Mode Cycle Time (t _{PC})	12	20	25	ns
Read/Write Cycle Time (t _{RC})	60	90	110	ns

PIN CONFIGURATION

20 (26) Pin SOJ, TSOP-2

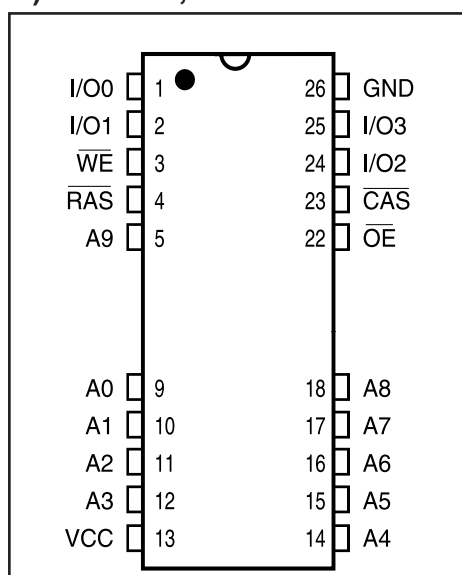

PIN DESCRIPTIONS

A0-A9	Address Inputs
I/O0-3	Data Inputs/Outputs
$\overline{\text{WE}}$	Write Enable
$\overline{\text{OE}}$	Output Enable
$\overline{\text{RAS}}$	Row Address Strobe
$\overline{\text{CAS}}$	Column Address Strobe
V _{CC}	Power
GND	Ground

IC41C4105 and IC41LV4105

FUNCTIONAL BLOCK DIAGRAM

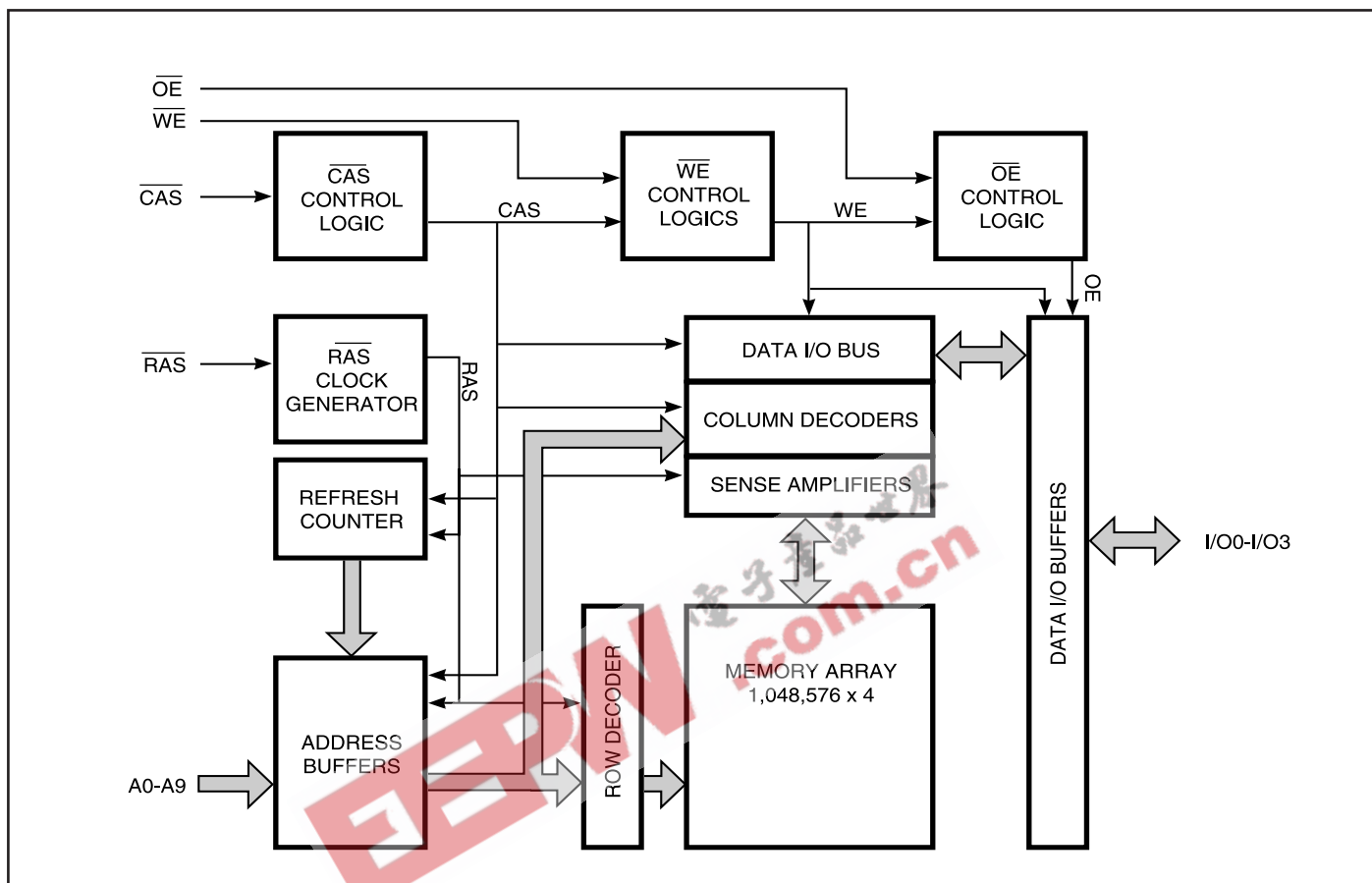

TRUTH TABLE

Function		RAS	CAS	WE	OE	Address tr/tc	I/O
Standby		H	H	X	X	X	High-Z
Read		L	L	H	L	ROW/COL	DOUT
Write: Word (Early Write)		L	L	L	X	ROW/COL	DIN
Read-Write		L	L	H→L	L→H	ROW/COL	DOUT, DIN
Hidden Refresh	Read	L→H→L	L	H	L	ROW/COL	DOUT
	Write ⁽¹⁾	L→H→L	L	L	X	ROW/COL	DOUT
RAS-Only Refresh		L	H	X	X	ROW/NA	High-Z
CBR Refresh		H→L	L	X	X	X	High-Z

Note:

1. EARLY WRITE only.

Functional Description

The IC41C4105 and IC41LV4105 are CMOS DRAMs optimized for high-speed bandwidth, low power applications. During READ or WRITE cycles, each bit is uniquely addressed through the 10 address bits. These are entered 10 bits (A0-A9) at a time. The row address is latched by the Row Address Strobe ($\overline{\text{RAS}}$). The column address is latched by the Column Address Strobe ($\overline{\text{CAS}}$). $\overline{\text{RAS}}$ is used to latch the first ten bits and $\overline{\text{CAS}}$ is used the latter ten bits.

Memory Cycle

A memory cycle is initiated by bring $\overline{\text{RAS}}$ LOW and it is terminated by returning both $\overline{\text{RAS}}$ and $\overline{\text{CAS}}$ HIGH. To ensure proper device operation and data integrity any memory cycle, once initiated, must not be ended or aborted before the minimum t_{RAS} time has expired. A new cycle must not be initiated until the minimum precharge time t_{RP} , t_{CP} has elapsed.

Read Cycle

A read cycle is initiated by the falling edge of $\overline{\text{CAS}}$ or $\overline{\text{OE}}$, whichever occurs last, while holding $\overline{\text{WE}}$ HIGH. The column address must be held for a minimum time specified by t_{AR} . Data Out becomes valid only when t_{RAC} , t_{AA} , t_{CAC} and t_{OE} are all satisfied. As a result, the access time is dependent on the timing relationships between these parameters.

Write Cycle

A write cycle is initiated by the falling edge of $\overline{\text{CAS}}$ and $\overline{\text{WE}}$, whichever occurs last. The input data must be valid at or before the falling edge of $\overline{\text{CAS}}$ or $\overline{\text{WE}}$, whichever occurs last.

Refresh Cycle

To retain data, 1,024 refresh cycles are required in each 16 ms period. There are two ways to refresh the memory:

1. By clocking each of the 1,024 row addresses (A0 through A9) with $\overline{\text{RAS}}$ at least once every 16 ms. Any read, write, read-modify-write or $\overline{\text{RAS}}$ -only cycle refreshes the addressed row.
2. Using a $\overline{\text{CAS}}$ -before- $\overline{\text{RAS}}$ refresh cycle. $\overline{\text{CAS}}$ -before- $\overline{\text{RAS}}$ refresh is activated by the falling edge of $\overline{\text{RAS}}$, while holding $\overline{\text{CAS}}$ LOW. In $\overline{\text{CAS}}$ -before- $\overline{\text{RAS}}$ refresh cycle, an internal 10-bit counter provides the row addresses and the external address inputs are ignored.

$\overline{\text{CAS}}$ -before- $\overline{\text{RAS}}$ is a refresh-only mode and no data access or device selection is allowed. Thus, the output remains in the High-Z state during the cycle.

Power-On

After application of the V_{CC} supply, an initial pause of 200 μs is required followed by a minimum of eight initialization cycles (any combination of cycles containing a $\overline{\text{RAS}}$ signal).

During power-on, it is recommended that $\overline{\text{RAS}}$ track with V_{CC} or be held at a valid V_{IH} to avoid current surges.

IC41C4105 and IC41LV4105

ABSOLUTE MAXIMUM RATINGS⁽¹⁾

Symbol	Parameters		Rating	Unit
V _T	Voltage on Any Pin Relative to GND	5V	-1.0 to +7.0	V
		3.3V	-0.5 to +4.6	
V _{CC}	Supply Voltage	5V	-1.0 to +7.0	V
		3.3V	-0.5 to +4.6	
I _{OUT}	Output Current		50	mA
P _D	Power Dissipation		1	W
T _A	Commercial Operation Temperature		0 to +70	°C
T _{STG}	Storage Temperature		-55 to +125	°C

Note:

1. Stress greater than those listed under ABSOLUTE MAXIMUM RATINGS may cause permanent damage to the device. This is a stress rating only and functional operation of the device at these or any other conditions above those indicated in the operational sections of this specification is not implied. Exposure to absolute maximum rating conditions for extended periods may affect reliability.

RECOMMENDED OPERATING CONDITIONS (Voltages are referenced to GND.)

Symbol	Parameter		Min.	Typ.	Max.	Unit
V _{CC}	Supply Voltage	5V	4.5	5.0	5.5	V
		3.3V	3.0	3.3	3.6	
V _{IH}	Input High Voltage	5V	2.4	-	V _{CC} + 1.0	V
		3.3V	2.0	-	V _{CC} + 0.3	
V _{IL}	Input Low Voltage	5V	-1.0	-	0.8	V
		3.3V	-0.3	-	0.8	
T _A	Commercial Ambient Temperature		0	-	70	°C

CAPACITANCE^(1,2)

Symbol	Parameter	Max.	Unit
C _{IN1}	Input Capacitance: A0-A9	5	pF
C _{IN2}	Input Capacitance: $\overline{\text{RAS}}$, $\overline{\text{CAS}}$, $\overline{\text{WE}}$, $\overline{\text{OE}}$	7	pF
C _{IO}	Data Input/Output Capacitance: I/O0-I/O3	7	pF

Notes:

1. Tested initially and after any design or process changes that may affect these parameters.
2. Test conditions: T_A = 25°C, f = 1 MHz.

IC41C4105 and IC41LV4105



ELECTRICAL CHARACTERISTICS⁽¹⁾

(Recommended Operating Conditions unless otherwise noted.)

Symbol	Parameter	Test Condition	Speed	Min.	Max.	Unit
I _{IL}	Input Leakage Current	Any input $0V \leq V_{IN} \leq V_{CC}$ Other inputs not under test = 0V		-5	5	μA
I _{IO}	Output Leakage Current	Output is disabled (Hi-Z) $0V \leq V_{OUT} \leq V_{CC}$		-5	5	μA
V _{OH}	Output High Voltage Level	I _{OH} = -5.0 mA with V _{CC} =5V I _{OH} = -2.0 mA with V _{CC} =3.3V		2.4	-	V
V _{OL}	Output Low Voltage Level	I _{OL} = 4.2 mA with V _{CC} =5V I _{OL} = 2 mA with V _{CC} =3.3V		-	0.4	V
I _{CC1}	Standby Current: TTL	$\overline{RAS}, \overline{CAS} \geq V_{IH}$	5V 3.3V	-	2 0.5	mA
I _{CC2}	Standby Current: CMOS	$\overline{RAS}, \overline{CAS} \geq V_{CC} - 0.2V$	5V 3.3V	-	1 0.5	mA
I _{CC3}	Operating Current: Random Read/Write ^(2,3,4) Average Power Supply Current	$\overline{RAS}, \overline{CAS}$, Address Cycling, t _{RC} = t _{RC} (min.)	-35 -50 -60	-	110 95 85	mA
I _{CC4}	Operating Current: Fast Page Mode ^(2,3,4) Average Power Supply Current	$\overline{RAS} = V_{IL}, \overline{CAS} \geq V_{IH}$ t _{RC} = t _{RC} (min.)	-35 -50 -60	-	90 80 70	mA
I _{CC5}	Refresh Current: \overline{RAS} -Only ^(2,3) Average Power Supply Current	\overline{RAS} Cycling, $\overline{CAS} \geq V_{IH}$ t _{RC} = t _{RC} (min.)	-35 -50 -60	-	110 95 85	mA
I _{CC6}	Refresh Current: CBR ^(2,3,5) Average Power Supply Current	$\overline{RAS}, \overline{CAS}$ Cycling t _{RC} = t _{RC} (min.)	-35 -50 -60	-	110 95 85	mA

Notes:

1. An initial pause of 200 μs is required after power-up followed by eight \overline{RAS} refresh cycles (\overline{RAS} -Only or CBR) before proper device operation is assured. The eight \overline{RAS} cycles wake-up should be repeated any time the t_{REF} refresh requirement is exceeded.
2. Dependent on cycle rates.
3. Specified values are obtained with minimum cycle time and the output open.
4. Column-address is changed once each Fast page cycle.
5. Enables on-chip refresh and address counters.



IC41C4105 and IC41LV4105

AC CHARACTERISTICS^(1,2,3,4,5,6)

(Recommended Operating Conditions unless otherwise noted.)

Symbol	Parameter	-35		-50		-60		Units
		Min.	Max.	Min.	Max.	Min.	Max.	
tRC	Random READ or WRITE Cycle Time	60	–	90	–	110	–	ns
tRAC	Access Time from $\overline{\text{RAS}}$ ^(6, 7)	–	35	–	50	–	60	ns
tCAC	Access Time from $\overline{\text{CAS}}$ ^(6, 8, 15)	–	10	–	14	–	15	ns
tAA	Access Time from Column-Address ⁽⁶⁾	–	18	–	25	–	30	ns
tRAS	$\overline{\text{RAS}}$ Pulse Width	35	10K	50	10K	60	10K	ns
tRP	$\overline{\text{RAS}}$ Precharge Time	20	–	30	–	40	–	ns
tCAS	$\overline{\text{CAS}}$ Pulse Width ⁽²³⁾	6	10K	8	10K	10	10K	ns
tCP	$\overline{\text{CAS}}$ Precharge Time ⁽⁹⁾	6	–	8	–	10	–	ns
tCSH	$\overline{\text{CAS}}$ Hold Time ⁽²¹⁾	35	–	50	–	60	–	ns
tRCD	$\overline{\text{RAS}}$ to $\overline{\text{CAS}}$ Delay Time ^(10, 20)	11	28	19	36	20	45	ns
tASR	Row-Address Setup Time	0	–	0	–	0	–	ns
tRAH	Row-Address Hold Time	6	–	8	–	10	–	ns
tASC	Column-Address Setup Time ⁽²⁰⁾	0	–	0	–	0	–	ns
tCAH	Column-Address Hold Time ⁽²⁰⁾	6	–	8	–	10	–	ns
tAR	Column-Address Hold Time (referenced to $\overline{\text{RAS}}$)	30	–	40	–	40	–	ns
tRAD	$\overline{\text{RAS}}$ to Column-Address Delay Time ⁽¹¹⁾	10	20	14	25	15	30	ns
tRAL	Column-Address to $\overline{\text{RAS}}$ Lead Time	18	–	25	–	30	–	ns
tRPC	$\overline{\text{RAS}}$ to $\overline{\text{CAS}}$ Precharge Time	0	–	0	–	0	–	ns
tRSH	$\overline{\text{RAS}}$ Hold Time	8	–	14	–	15	–	ns
tCLZ	$\overline{\text{CAS}}$ to Output in Low-Z ^(15, 24)	3	–	3	–	3	–	ns
tCRP	$\overline{\text{CAS}}$ to $\overline{\text{RAS}}$ Precharge Time ⁽²¹⁾	5	–	5	–	5	–	ns
tOD	Output Disable Time ^(19, 24)	3	15	3	15	3	15	ns
tOE	Output Enable Time ^(15, 16)	–	10	–	15	–	15	ns
tOES	OE LOW to $\overline{\text{CAS}}$ HIGH Setup Time	5	–	5	–	5	–	ns
tRCS	Read Command Setup Time ^(17, 20)	0	–	0	–	0	–	ns
tRRH	Read Command Hold Time (referenced to $\overline{\text{RAS}}$) ⁽¹²⁾	0	–	0	–	0	–	ns
tRCH	Read Command Hold Time (referenced to $\overline{\text{CAS}}$) ^(12, 17, 21)	0	–	0	–	0	–	ns
tWCH	Write Command Hold Time ⁽¹⁷⁾	5	–	8	–	10	–	ns
tWCR	Write Command Hold Time (referenced to $\overline{\text{RAS}}$) ⁽¹⁷⁾	30	–	40	–	50	–	ns
tWP	Write Command Pulse Width ⁽¹⁷⁾	5	–	8	–	10	–	ns
tRWL	Write Command to $\overline{\text{RAS}}$ Lead Time ⁽¹⁷⁾	8	–	14	–	15	–	ns
tCWL	Write Command to $\overline{\text{CAS}}$ Lead Time ^(17, 21)	8	–	14	–	15	–	ns
tWCS	Write Command Setup Time ^(14, 17, 20)	0	–	0	–	0	–	ns
tDHR	Data-in Hold Time (referenced to $\overline{\text{RAS}}$)	30	–	40	–	45	–	ns

IC41C4105 and IC41LV4105



AC CHARACTERISTICS (Continued)^(1,2,3,4,5,6)

(Recommended Operating Conditions unless otherwise noted.)

Symbol	Parameter	-35		-50		-60		Units
		Min.	Max.	Min.	Max.	Min.	Max.	
tACH	Column-Address Setup Time to $\overline{\text{CAS}}$ Precharge during WRITE Cycle	15	–	15	–	15	–	ns
tOEH	$\overline{\text{OE}}$ Hold Time from $\overline{\text{WE}}$ during READ-MODIFY-WRITE cycle ⁽¹⁸⁾	8	–	10	–	15	–	ns
tDS	Data-In Setup Time ^(15, 22)	0	–	0	–	0	–	ns
tDH	Data-In Hold Time ^(15, 22)	6	–	8	–	10	–	ns
tRWC	READ-MODIFY-WRITE Cycle Time	80	–	125	–	140	–	ns
tRWD	$\overline{\text{RAS}}$ to $\overline{\text{WE}}$ Delay Time during READ-MODIFY-WRITE Cycle ⁽¹⁴⁾	45	–	70	–	80	–	ns
tCWD	$\overline{\text{CAS}}$ to $\overline{\text{WE}}$ Delay Time ^(14, 20)	25	–	34	–	36	–	ns
tAWD	Column-Address to $\overline{\text{WE}}$ Delay Time ⁽¹⁴⁾	30	–	42	–	49	–	ns
tPC	Fast Page Mode READ or WRITE Cycle Time	12	–	20	–	25	–	ns
tRASP	Fast Page Mode $\overline{\text{RAS}}$ Pulse Width	35	100K	50	100K	60	100K	ns
tCPA	Access Time from $\overline{\text{CAS}}$ Precharge ⁽¹⁵⁾	–	21	–	27	–	34	ns
tPRWC	Fast Page Mode READ-WRITE Cycle Time	40	–	47	–	56	–	ns
tOFF	Output Buffer Turn-Off Delay from $\overline{\text{CAS}}$ or $\overline{\text{RAS}}$ ^(13,15,19, 24)	3	15	3	15	3	15	ns
tCSR	$\overline{\text{CAS}}$ Setup Time (CBR REFRESH) ^(20, 25)	8	–	10	–	10	–	ns
tCHR	$\overline{\text{CAS}}$ Hold Time (CBR REFRESH) ^(21, 25)	8	–	10	–	10	–	ns
tORD	$\overline{\text{OE}}$ Setup Time prior to $\overline{\text{RAS}}$ during HIDDEN REFRESH Cycle	0	–	0	–	0	–	ns
tREF	Auto Refresh Period 1,024 Cycles	–	16	–	16	–	16	ms
t _r	Transition Time (Rise or Fall) ^(2, 3)	1	15	1	50	1	50	ns

AC TEST CONDITIONS

Output load: Two TTL Loads and 50 pF ($V_{CC} = 5.0V + 10\%$)
 One TTL Load and 50 pF ($V_{CC} = 3.3V + 10\%$)

Input timing reference levels: $V_{IH} = 2.4V$, $V_{IL} = 0.8V$ ($V_{CC} = 5.0V + 10\%$)
 $V_{IH} = 2.4V$, $V_{IL} = 0.8V$ ($V_{CC} = 3.3V + 10\%$)

Output timing reference levels: $V_{OH} = 2.0V$, $V_{OL} = 0.8V$ ($V_{CC} = 5.0V + 10\%$, $3.3V + 10\%$)

IC41C4105 and IC41LV4105

Notes:

1. An initial pause of 200 μ s is required after power-up followed by eight $\overline{\text{RAS}}$ refresh cycle ($\overline{\text{RAS}}$ -Only or CBR) before proper device operation is assured. The eight $\overline{\text{RAS}}$ cycles wake-up should be repeated any time the t_{REF} refresh requirement is exceeded.
2. V_{IH} (MIN) and V_{IL} (MAX) are reference levels for measuring timing of input signals. Transition times, are measured between V_{IH} and V_{IL} (or between V_{IL} and V_{IH}) and assume to be 1 ns for all inputs.
3. In addition to meeting the transition rate specification, all input signals must transit between V_{IH} and V_{IL} (or between V_{IL} and V_{IH}) in a monotonic manner.
4. If $\overline{\text{CAS}}$ and $\overline{\text{RAS}} = V_{\text{IH}}$, data output is High-Z.
5. If $\overline{\text{CAS}} = V_{\text{IL}}$, data output may contain data from the last valid READ cycle.
6. Measured with a load equivalent to one TTL gate and 50 pF.
7. Assumes that $t_{\text{RCD}} < t_{\text{RCD}}(\text{MAX})$. If t_{RCD} is greater than the maximum recommended value shown in this table, t_{RAC} will increase by the amount that t_{RCD} exceeds the value shown.
8. Assumes that $t_{\text{RCD}} > t_{\text{RCD}}(\text{MAX})$.
9. If $\overline{\text{CAS}}$ is LOW at the falling edge of $\overline{\text{RAS}}$, data out will be maintained from the previous cycle. To initiate a new cycle and clear the data output buffer, $\overline{\text{CAS}}$ and $\overline{\text{RAS}}$ must be pulsed for t_{CP} .
10. Operation with the $t_{\text{RCD}}(\text{MAX})$ limit ensures that $t_{\text{RAC}}(\text{MAX})$ can be met. $t_{\text{RCD}}(\text{MAX})$ is specified as a reference point only; if t_{RCD} is greater than the specified $t_{\text{RCD}}(\text{MAX})$ limit, access time is controlled exclusively by t_{CAC} .
11. Operation within the $t_{\text{RAD}}(\text{MAX})$ limit ensures that $t_{\text{RCD}}(\text{MAX})$ can be met. $t_{\text{RAD}}(\text{MAX})$ is specified as a reference point only; if t_{RAD} is greater than the specified $t_{\text{RAD}}(\text{MAX})$ limit, access time is controlled exclusively by t_{AA} .
12. Either t_{RCH} or t_{RRH} must be satisfied for a READ cycle.
13. $t_{\text{OFF}}(\text{MAX})$ defines the time at which the output achieves the open circuit condition; it is not a reference to V_{OH} or V_{OL} .
14. t_{WCS} , t_{RWD} , t_{AWD} and t_{CWD} are restrictive operating parameters in LATE WRITE and READ-MODIFY-WRITE cycle only. If $t_{\text{WCS}} > t_{\text{WCS}}(\text{MIN})$, the cycle is an EARLY WRITE cycle and the data output will remain open circuit throughout the entire cycle. If $t_{\text{RWD}} > t_{\text{RWD}}(\text{MIN})$, $t_{\text{AWD}} > t_{\text{AWD}}(\text{MIN})$ and $t_{\text{CWD}} > t_{\text{CWD}}(\text{MIN})$, the cycle is a READ-WRITE cycle and the data output will contain data read from the selected cell. If neither of the above conditions is met, the state of I/O (at access time and until $\overline{\text{CAS}}$ and $\overline{\text{RAS}}$ or $\overline{\text{OE}}$ go back to V_{IH}) is indeterminate. $\overline{\text{OE}}$ held HIGH and $\overline{\text{WE}}$ taken LOW after $\overline{\text{CAS}}$ goes LOW result in a LATE WRITE ($\overline{\text{OE}}$ -controlled) cycle.
15. Output parameter (I/O) is referenced to corresponding $\overline{\text{CAS}}$ input.
16. During a READ cycle, if $\overline{\text{OE}}$ is LOW then taken HIGH before $\overline{\text{CAS}}$ goes HIGH, I/O goes open. If $\overline{\text{OE}}$ is tied permanently LOW, a LATE WRITE or READ-MODIFY-WRITE is not possible.
17. Write command is defined as $\overline{\text{WE}}$ going low.
18. LATE WRITE and READ-MODIFY-WRITE cycles must have both t_{OD} and t_{OEH} met ($\overline{\text{OE}}$ HIGH during WRITE cycle) in order to ensure that the output buffers will be open during the WRITE cycle. The I/Os will provide the previously written data if $\overline{\text{CAS}}$ remains LOW and $\overline{\text{OE}}$ is taken back to LOW after t_{OEH} is met.
19. The I/Os are in open during READ cycles once t_{OD} or t_{OFF} occur.
20. Determined by falling edge of $\overline{\text{CAS}}$.
21. Determined by rising edge of $\overline{\text{CAS}}$.
22. These parameters are referenced to $\overline{\text{CAS}}$ leading edge in EARLY WRITE cycles and $\overline{\text{WE}}$ leading edge in LATE WRITE or READ-MODIFY-WRITE cycles.
23. $\overline{\text{CAS}}$ must meet minimum pulse width.
24. The 3 ns minimum is a parameter guaranteed by design.
25. Enables on-chip refresh and address counters.

READ CYCLE

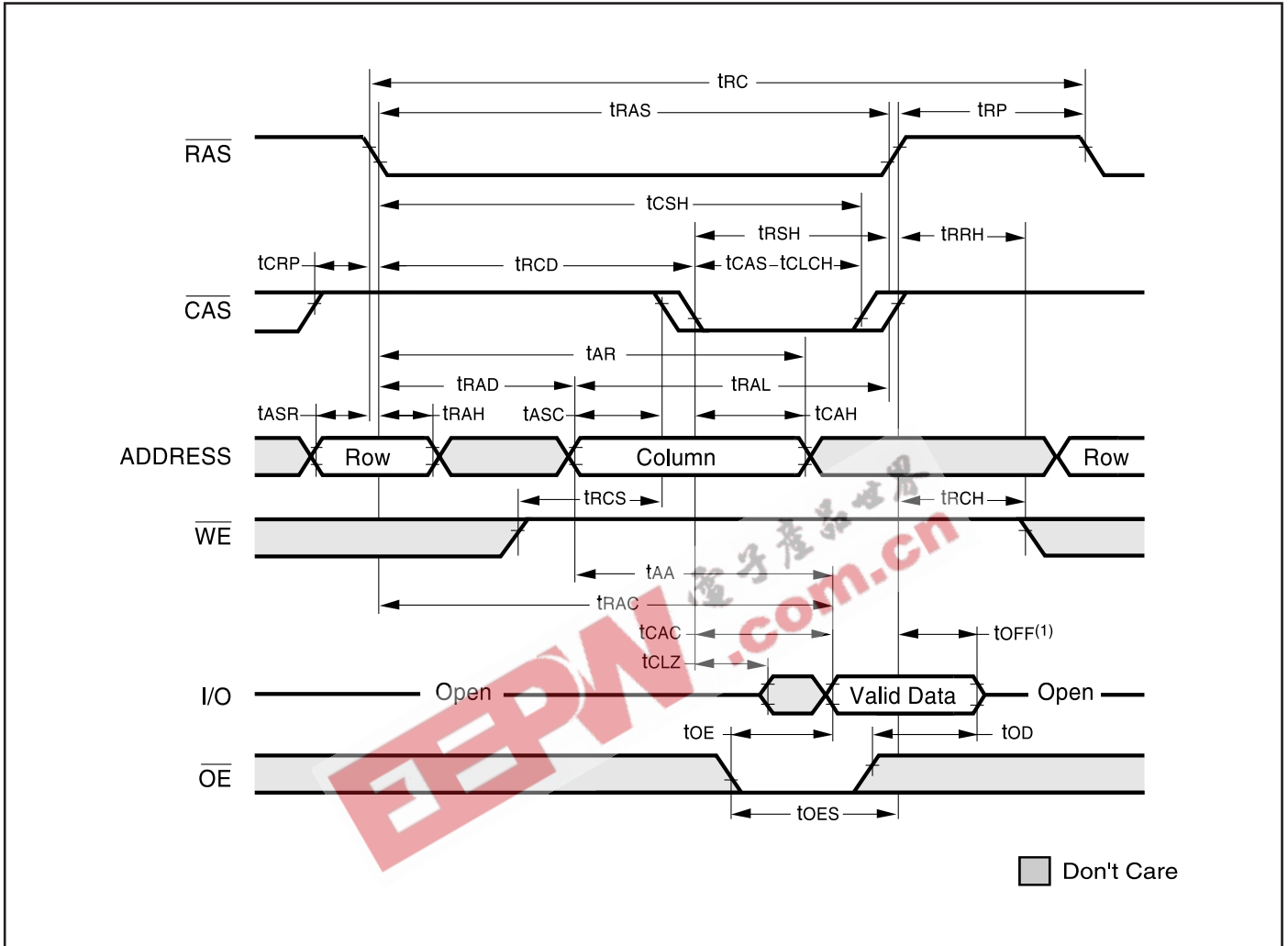

Note:

1. $t_{OFF(1)}$ is referenced from rising edge of \overline{RAS} or \overline{CAS} , whichever occurs last.

IC41C4105 and IC41LV4105

READ WRITE CYCLE (LATE WRITE and READ-MODIFY-WRITE Cycles)

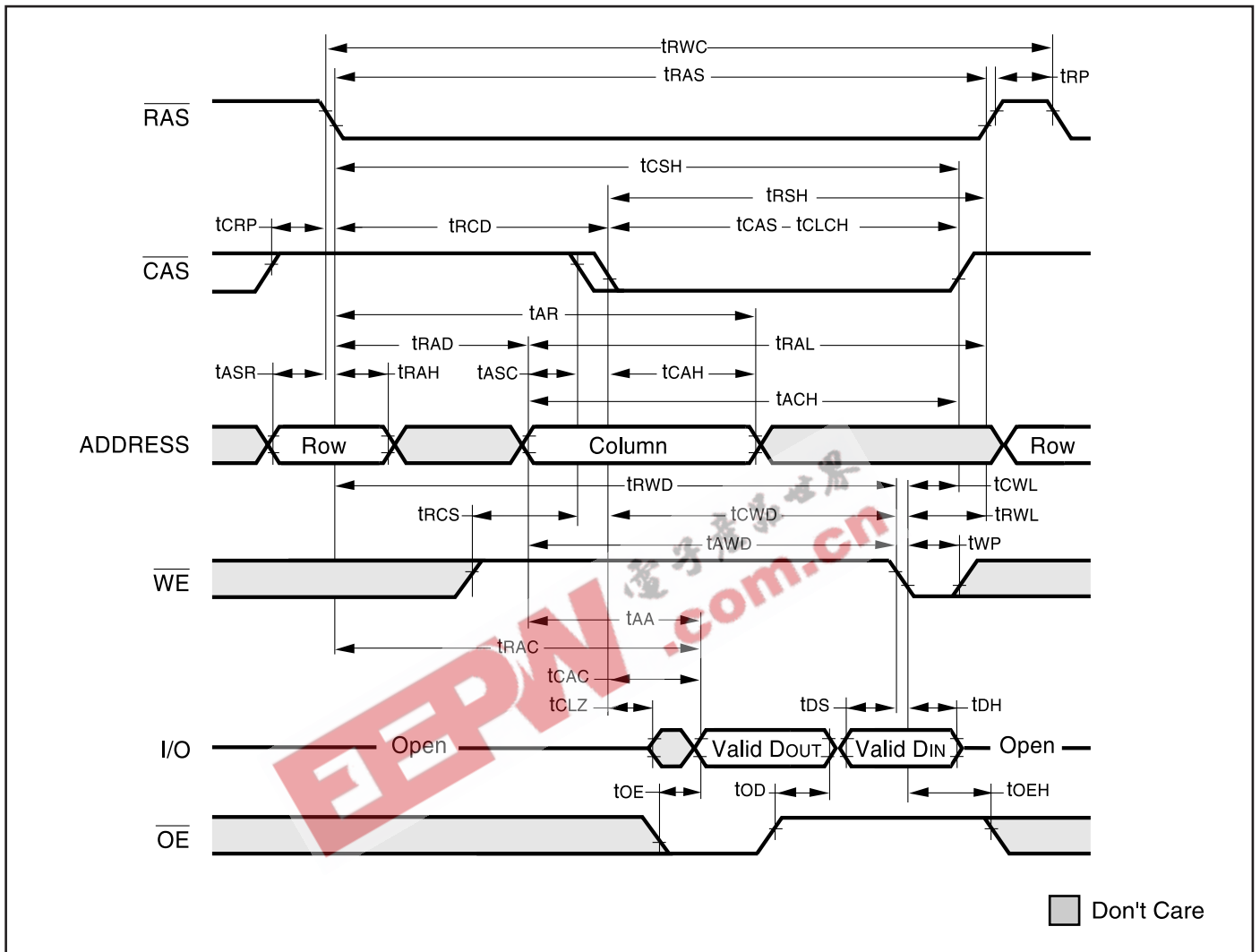

EARLY WRITE CYCLE (\overline{OE} = DON'T CARE)

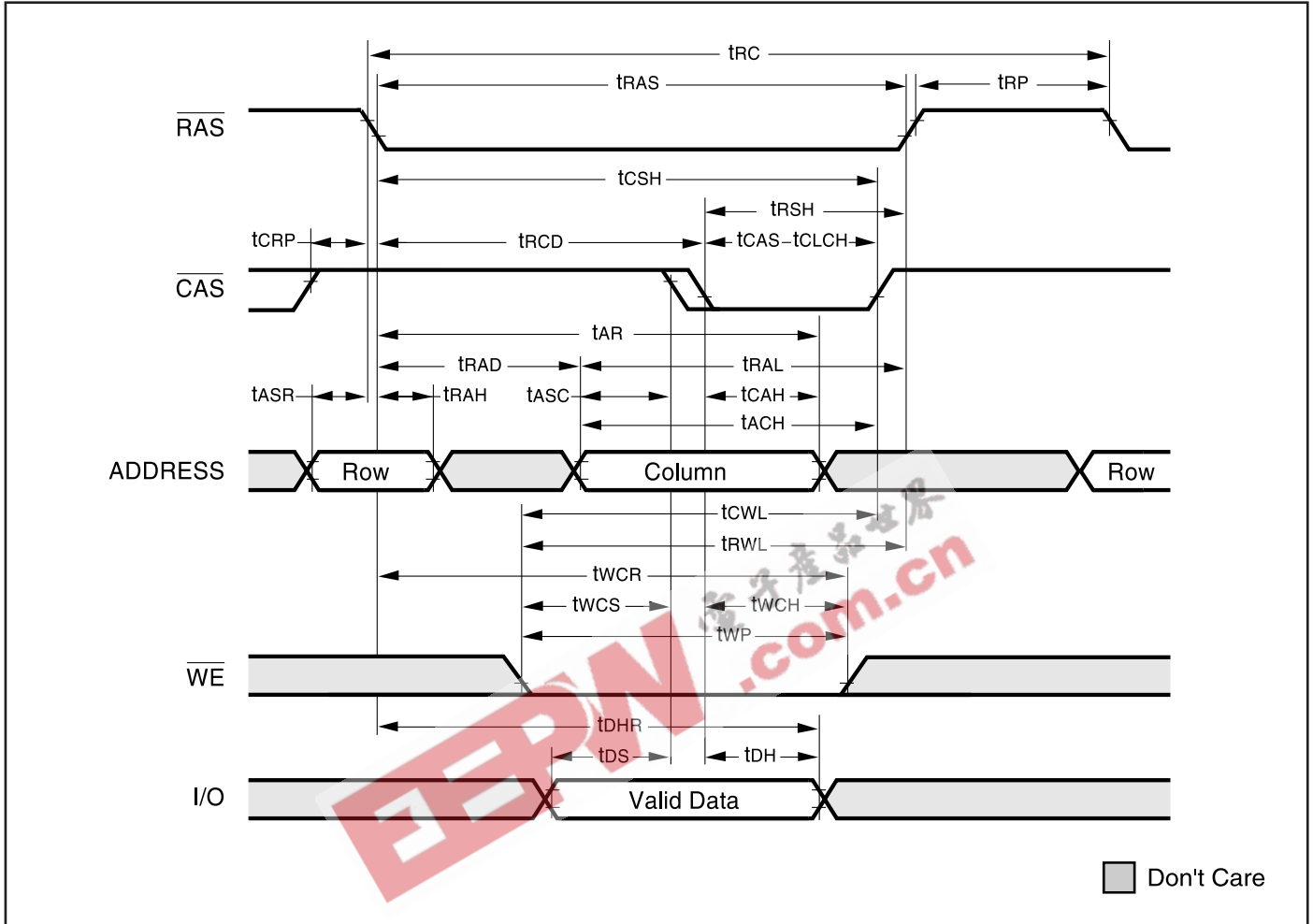

IC41C4105 and IC41LV4105

FAST PAGE MODE READ CYCLE

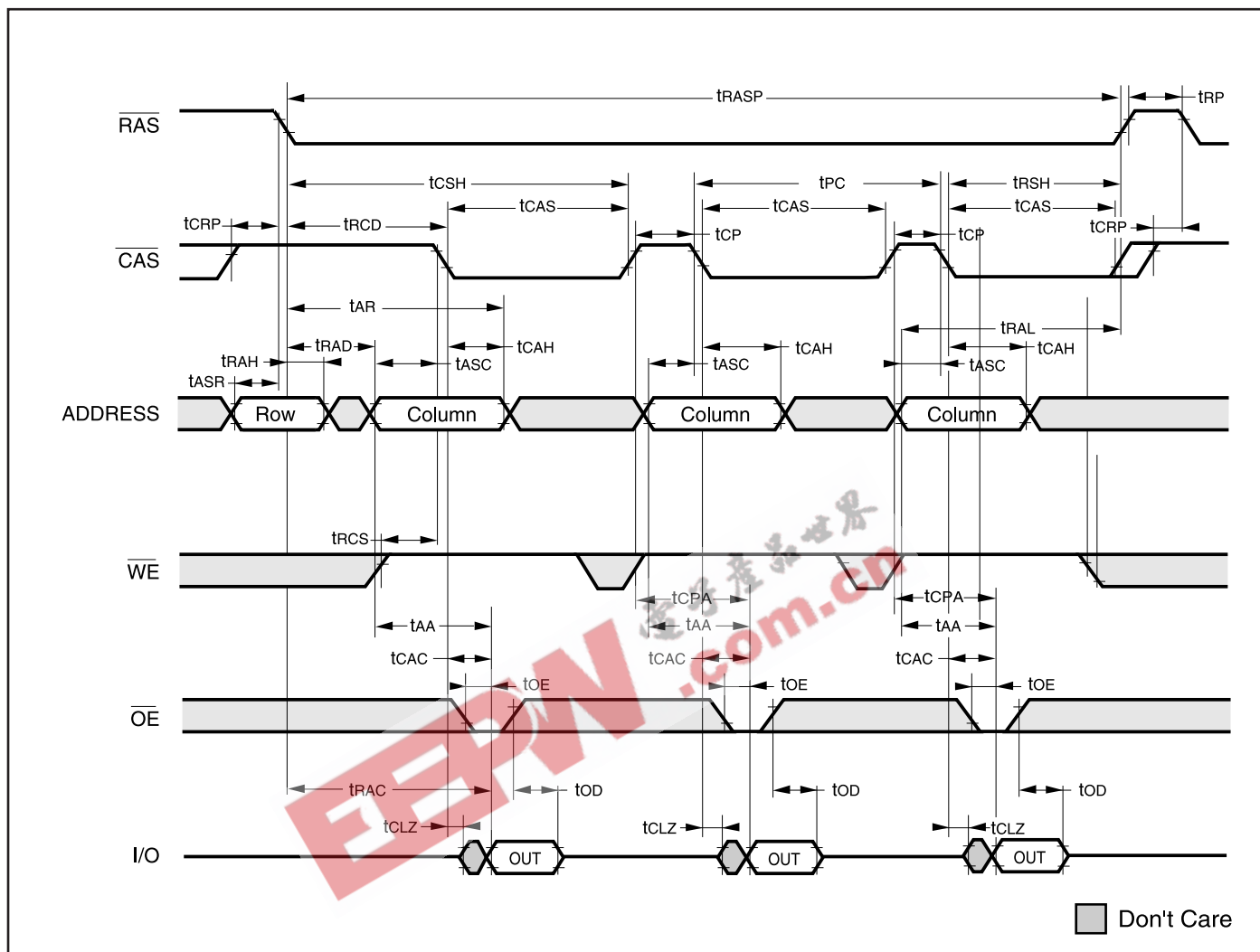

FAST PAGE MODE EARLY WRITE CYCLE

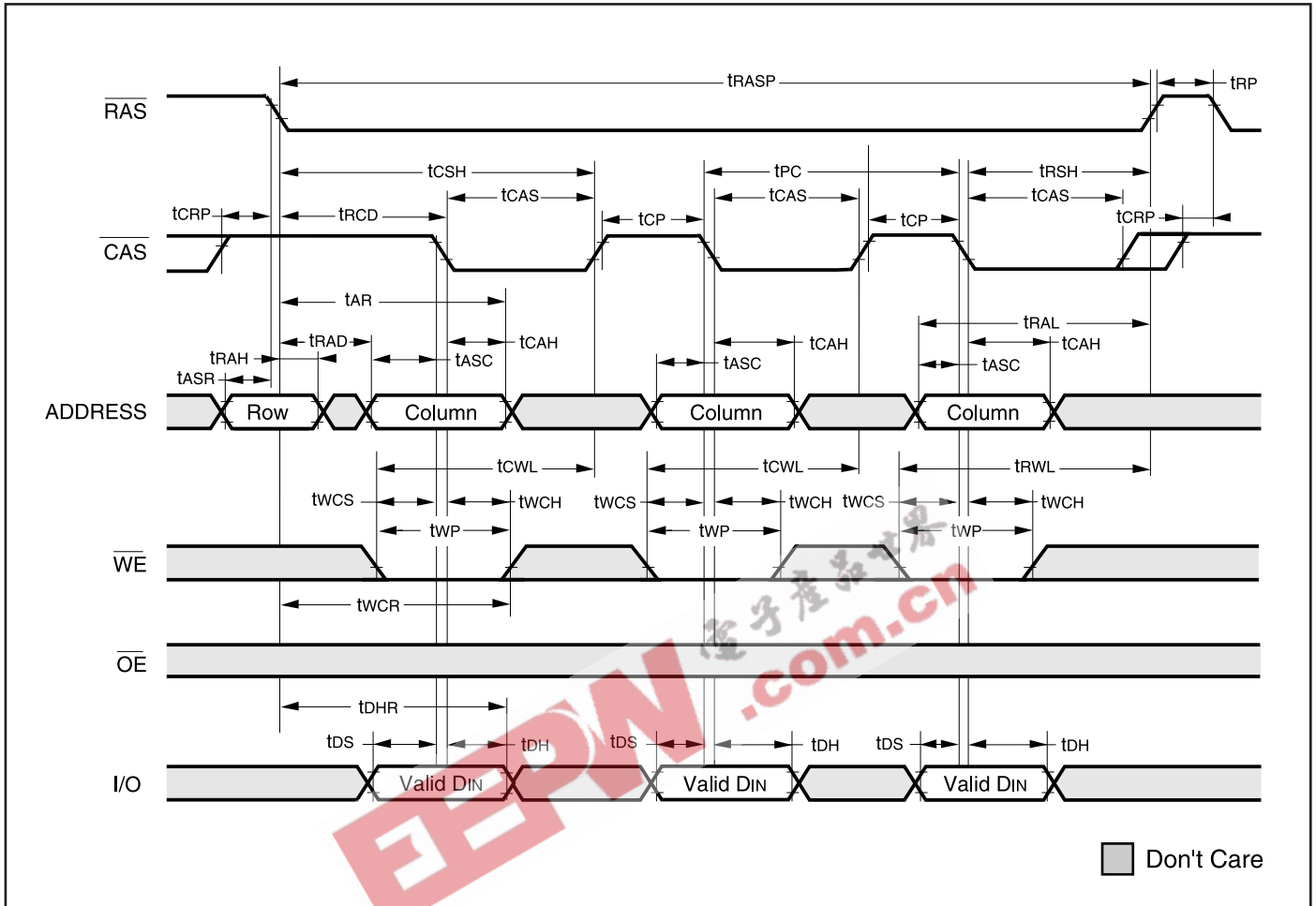

IC41C4105 and IC41LV4105



CBR REFRESH CYCLE (Addresses; \overline{WE} , \overline{OE} = DON'T CARE)

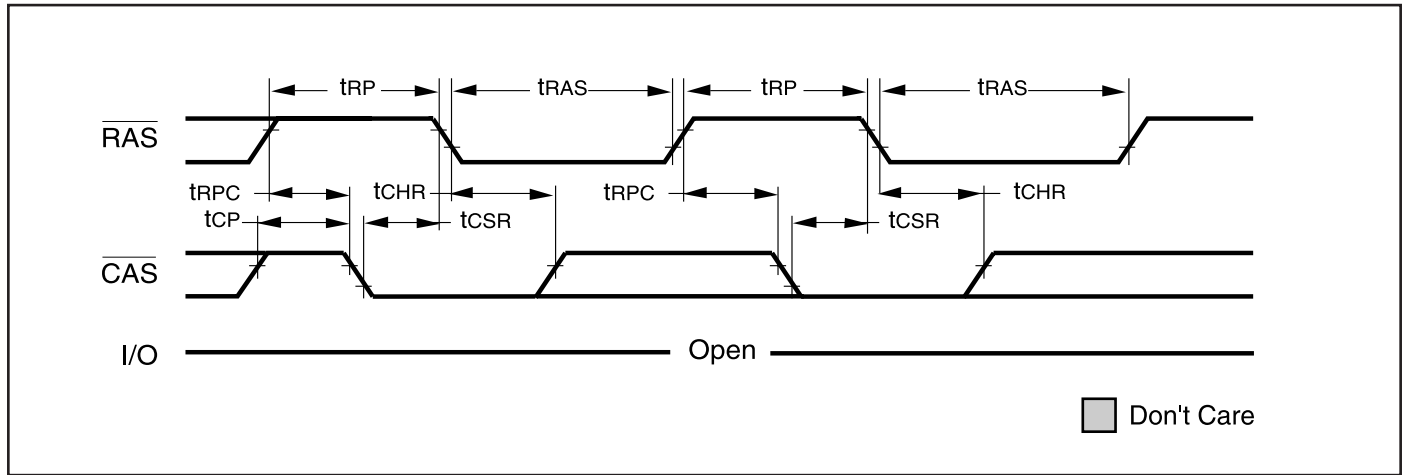

HIDDEN REFRESH CYCLE⁽¹⁾ (\overline{WE} = HIGH; \overline{OE} = LOW)

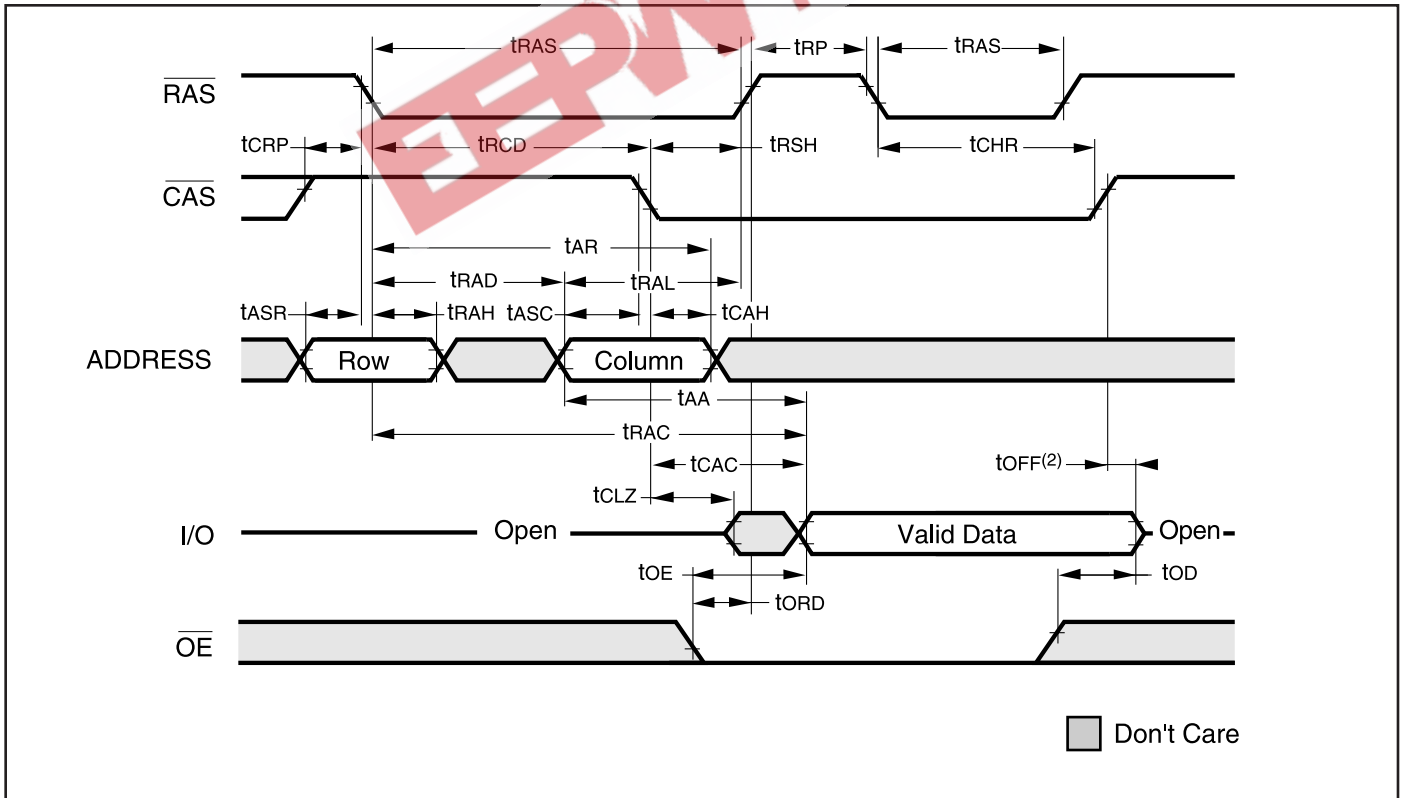

Notes:

1. A Hidden Refresh may also be performed after a Write Cycle. In this case, \overline{WE} = LOW and \overline{OE} = HIGH.
2. toff is referenced from rising edge of RAS or CAS, whichever occurs last.



IC41C4105 and IC41LV4105

ORDERING INFORMATION

Commercial Range: 0°C to 70°C

Voltage: 5V

Speed (ns)	Order Part No.	Package
35	IC41C4105-35J	300mil SOJ
35	IC41C4105-35T	300mil TSOP-2
50	IC41C4105-50J	300mil SOJ
50	IC41C4105-50T	300mil TSOP-2
60	IC41C4105-60J	300-mil SOJ
60	IC41C4105-60T	300mil TSOP-2

Voltage: 3.3V

Speed (ns)	Order Part No.	Package
35	IC41LV4105-35J	300mil SOJ
35	IC41LV4105-35T	300mil TSOP-2
50	IC41LV4105-50J	300mil SOJ
50	IC41LV4105-50T	300mil TSOP-2
60	IC41LV4105-60J	300mil SOJ
60	IC41LV4105-60T	300mil TSOP-2



Integrated Circuit Solution Inc.

HEADQUARTER:
NO.2, TECHNOLOGY RD. V, SCIENCE-BASED INDUSTRIAL PARK,
HSIN-CHU, TAIWAN, R.O.C.
TEL: 886-3-5780333
Fax: 886-3-5783000

BRANCH OFFICE:
7F, NO. 106, SEC. 1, HSIN-TAI 5TH ROAD,
HSICHIH TAIPEI COUNTY, TAIWAN, R.O.C.
TEL: 886-2-26962140
FAX: 886-2-26962252
<http://www.icsi.com.tw>