



Integrated
Circuit
Systems, Inc.

PRELIMINARY

ICS840001-31

FEMTOCLOCKS™ CRYSTAL-TO-LVCMOS/LVTTL FREQUENCY SYNTHESIZER

GENERAL DESCRIPTION



The ICS840001-31 is a two output LVCMOS/LVTTL Synthesizer and a member of the HiPerClocks™ family of high performance devices from ICS. One output is the LVCMOS/LVTTL main synthesized clock output (Q) and one output is a three-state LVCMOS/LVTTL reference clock (REF_CLK) output at the frequency of the crystal oscillator. The device can accept 26.5625MHz and 40MHz crystals and can synthesize 106.25MHz or 100MHz outputs. The ICS840001-31 has excellent <1ps phase jitter performance over the 637kHz – 10MHz integration range. The ICS840001-31 is packaged in a 3mm x 3mm 16-pin VFQFN, making it ideal for use on space constrained boards.

FEATURES

- (2) LVCMOS/LVTTL outputs, 20Ω typical output impedance
 - (1) Main clock output (Q)
 - (1) Three-state reference clock output (REF_CLK)
- Crystal oscillator interface can accept 26.5625MHz or 40MHz 18pF parallel resonant crystals
- Output frequency range: 106.25MHz or 100MHz
- VCO range: 490MHz to 640MHz
- RMS phase jitter @ 106.25MHz, using a 26.5625MHz crystal (637kHz - 10MHz): 0.38ps (typical)
- 3.3V operating supply
- 0°C to 70°C ambient operating temperature

FUNCTION TABLE

Inputs				Outputs		Application
Crystal	M	OE	VCO (MHz)	Q Frequency (MHz)	REF_CLK Frequency (MHz)	
26.5625	0	0	637.5	106.25	High-Z	Fibre Channel
40	1 (or Floating)	1 (or Floating)	600	100	40	Serial Attached (SCSI)

BLOCK DIAGRAM

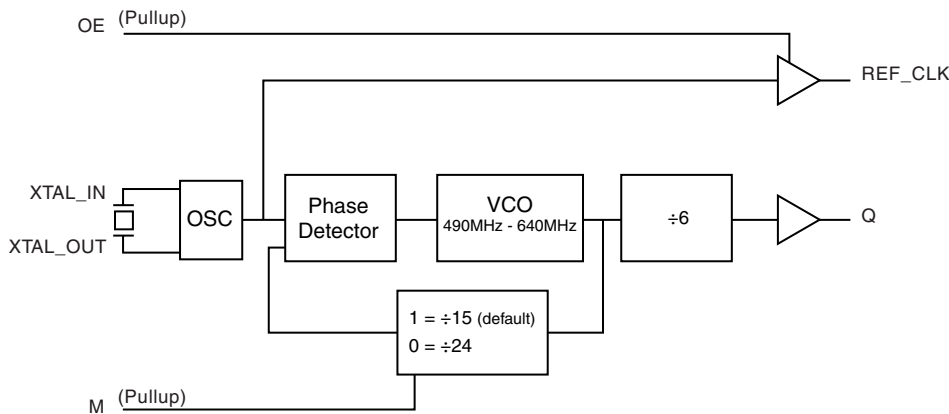

PIN ASSIGNMENT

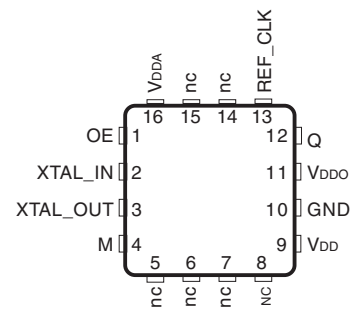

ICS840001-31

16-Lead VFQFN

3mm x 3mm x 0.95 package body

K Package

Top View

The Preliminary Information presented herein represents a product in prototyping or pre-production. The noted characteristics are based on initial product characterization. Integrated Circuit Systems, Incorporated (ICS) reserves the right to change any circuitry or specifications without notice.



Integrated
Circuit
Systems, Inc.

PRELIMINARY

ICS840001-31
FEMTOCLOCKS™ CRYSTAL-TO-
LVCMOS/LVTTL FREQUENCY SYNTHESIZER

TABLE 1. PIN DESCRIPTIONS

Number	Name	Type		Description
1	OE	Input	Pullup	Output enable pin. When HIGH, REF_CLK output is enabled. When LOW, forces REF_CLK to HiZ state. LVCMOS/LVTTL interface levels.
2,3	XTAL_IN, XTAL_OUT	Input		Crystal oscillator interface. XTAL_IN is the input. XTAL_OUT is the output.
4	M	Input	Pullup	M divider input. 0 = ÷24, 1 = ÷15 (default). LVCMOS/LVTTL interface levels.
5, 6, 7, 8, 14, 15	nc	Unused		No connect.
9	V _{DD}	Power		Core supply pin.
10	GND	Power		Power supply ground.
11	V _{DDO}	Power		Output supply pin.
12	Q	Output		Single-ended clock output. LVCMOS/LVTTL interface levels. 20Ω typical output impedance.
13	REF_CLK	Output		Single-ended three-state reference clock output. LVCMOS/LVTTL interface levels. 20Ω typical output impedance.
16	V _{DDA}	Power		Analog supply pin.

NOTE: *Pullup* refers to internal input resistors. See Table 2, Pin Characteristics, for typical values.

TABLE 2. PIN CHARACTERISTICS

Symbol	Parameter	Test Conditions	Minimum	Typical	Maximum	Units
C _{IN}	Input Capacitance			4		pF
C _{PD}	Power Dissipation Capacitance	V _{DD} , V _{DDA} , V _{DDO} = 3.465V		8		pF
R _{PULLUP}	Input Pullup Resistor			51		kΩ
R _{OUT}	Output Impedance			20		Ω



Integrated
Circuit
Systems, Inc.

PRELIMINARY

ICS840001-31
FEMTOCLOCKS™ CRYSTAL-TO-
LVCMOS/LVTTL FREQUENCY SYNTHESIZER

ABSOLUTE MAXIMUM RATINGS

Supply Voltage, V_{DD}	4.6V
Inputs, V_I	-0.5V to $V_{DD} + 0.5V$
Outputs, V_O	-0.5V to $V_{DD} + 0.5V$
Package Thermal Impedance, θ_{JA}	51.5°C/W (0 lfpm)
Storage Temperature, T_{STG}	-65°C to 150°C

NOTE: Stresses beyond those listed under Absolute Maximum Ratings may cause permanent damage to the device. These ratings are stress specifications only. Functional operation of product at these conditions or any conditions beyond those listed in the *DC Characteristics* or *AC Characteristics* is not implied. Exposure to absolute maximum rating conditions for extended periods may affect product reliability.

TABLE 4A. POWER SUPPLY DC CHARACTERISTICS, $V_{DD} = V_{DDA} = V_{DDO} = 3.3V \pm 5\%$, $T_A = 0^\circ C$ TO $70^\circ C$

Symbol	Parameter	Test Conditions	Minimum	Typical	Maximum	Units
V_{DD}	Core Supply Voltage		3.135	3.3	3.465	V
V_{DDA}	Analog Supply Voltage		3.135	3.3	3.465	V
V_{DDO}	Output Supply Voltage		3.135	3.3	3.465	V
I_{DD}	Power Supply Current			70		mA
I_{DDA}	Analog Supply Current			6		mA
I_{DDO}	Output Supply Current			27		mA

TABLE 4B. LVCMOS/LVTTL DC CHARACTERISTICS, $V_{DD} = V_{DDA} = V_{DDO} = 3.3V \pm 5\%$, $T_A = 0^\circ C$ TO $70^\circ C$

Symbol	Parameter	Test Conditions	Minimum	Typical	Maximum	Units
V_{IH}	Input High Voltage		2		$V_{DD} + 0.3$	V
V_{IL}	Input Low Voltage		-0.3		0.8	V
I_{IH}	Input High Current	OE, M $V_{DD} = V_{IN} = 3.465V$			5	μA
I_{IL}	Input Low Current	OE, M $V_{DD} = 3.465V, V_{IN} = 0V$	-150			μA
V_{OH}	Output High Voltage; NOTE 1		2.6			V
V_{OL}	Output Low Voltage; NOTE 1				0.5	V

NOTE 1: Outputs terminated with 50Ω to $V_{DD}/2$. See Parameter Measurement Information Section, "3.3V Output Load Test Circuit".

TABLE 5. CRYSTAL CHARACTERISTICS

Parameter	Test Conditions	Minimum	Typical	Maximum	Units
Mode of Oscillation		Fundamental			
Frequency		26.5625		40	MHz
Equivalent Series Resistance (ESR)				50	Ω
Shunt Capacitance				7	pF
Drive Level				1	mW



Integrated
Circuit
Systems, Inc.

PRELIMINARY

ICS840001-31
FEMTOCLOCKS™ CRYSTAL-TO-
LVCMOS/LVTTL FREQUENCY SYNTHESIZER

TABLE 6. AC CHARACTERISTICS, $V_{DD} = V_{DDA} = V_{DDO} = 3.3V \pm 5\%$, $T_A = 0^\circ C$ TO $70^\circ C$

Symbol	Parameter	Test Conditions	Minimum	Typical	Maximum	Units
f_{OUT}	Output Frequency			100		MHz
				106.25		MHz
$f_{jit}(\emptyset)$	RMS Phase Jitter (Random); NOTE 1	100MHz, Integration Range: 637kHz to 10MHz		0.54		ps
		106.25MHz, Integration Range: 637kHz to 10MHz		0.38		ps
t_R / t_F	Output Rise/Fall Time	20% to 80%		470		ps
odc	Output Duty Cycle			50		%

All parameters are characterized @ 100MHz and 106.25MHz.

NOTE 1: Please refer to the Phase Noise Plot.

EEPW 电子产品世界
.com.cn



Integrated
Circuit
Systems, Inc.

PRELIMINARY

ICS840001-31
FEMTOCLOCKS™ CRYSTAL-TO-
LVCMOS/LVTTL FREQUENCY SYNTHESIZER

PARAMETER MEASUREMENT INFORMATION

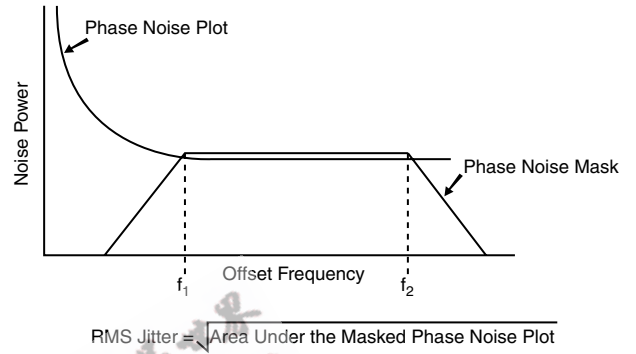
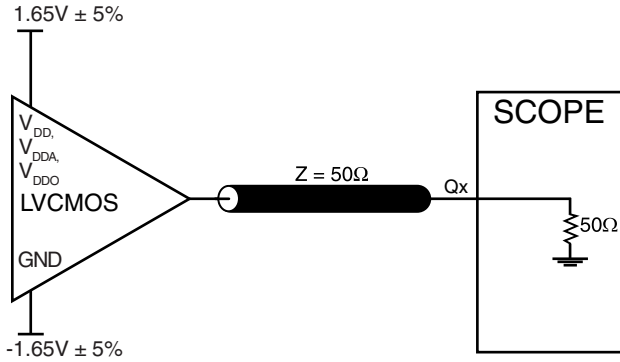

3.3V OUTPUT LOAD AC TEST CIRCUIT

RMS PHASE JITTER

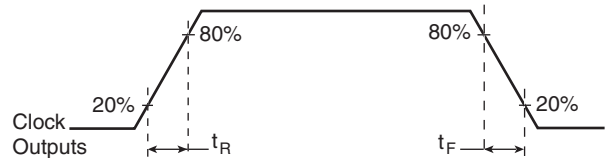
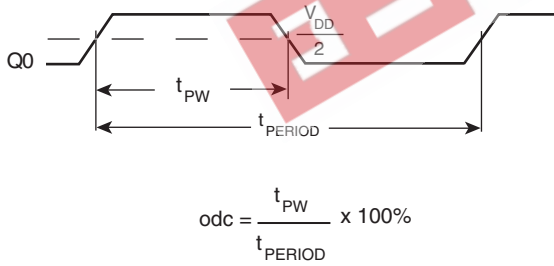

OUTPUT DUTY CYCLE/PULSE WIDTH/PERIOD

OUTPUT RISE/FALL TIME



Integrated
Circuit
Systems, Inc.

PRELIMINARY

ICS840001-31
FEMTOCLOCKS™ CRYSTAL-TO-
LVCMOS/LVTTL FREQUENCY SYNTHESIZER

APPLICATION INFORMATION

POWER SUPPLY FILTERING TECHNIQUES

As in any high speed analog circuitry, the power supply pins are vulnerable to random noise. The ICS840001-31 provides separate power supplies to isolate any high switching noise from the outputs to the internal PLL. V_{DD} , V_{DDA} and V_{DDO} should be individually connected to the power supply plane through vias, and bypass capacitors should be used for each pin. To achieve optimum jitter performance, power supply isolation is required. *Figure 1* illustrates how a 10Ω resistor along with a $10\mu\text{F}$ and a $.01\mu\text{F}$ bypass capacitor should be connected to each V_{DDA} pin.

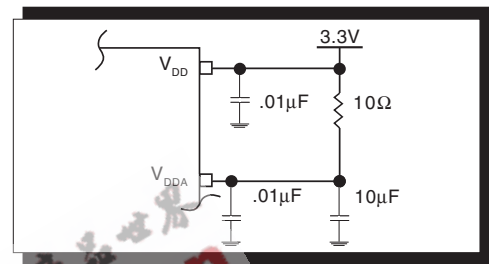

FIGURE 1. POWER SUPPLY FILTERING

CRYSTAL INPUT INTERFACE

The ICS840001-31 has been characterized with 18pF parallel resonant crystals. The capacitor values, C_1 and C_2 , shown in *Figure 2* below were determined using a 26.5625MHz , 18pF parallel resonant crystal and were chosen to minimize the ppm error. The optimum C_1 and C_2 values can be slightly adjusted for different board layouts.

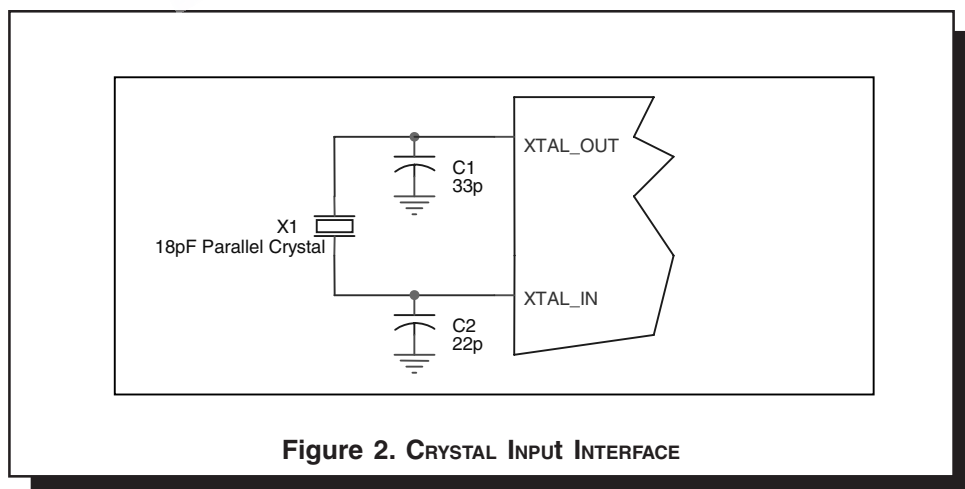

Figure 2. CRYSTAL INPUT INTERFACE



Integrated
Circuit
Systems, Inc.

PRELIMINARY

ICS840001-31
FEMTOCLOCKS™ CRYSTAL-TO-
LVCMOS/LVTTL FREQUENCY SYNTHESIZER

RELIABILITY INFORMATION

TABLE 7. θ_{JA} VS. AIR FLOW TABLE FOR 16 LEAD VFQFN

θ_{JA} at 0 Air Flow (Linear Feet per Minute)	
Multi-Layer PCB, JEDEC Standard Test Boards	0 51.5°C/W

TRANSISTOR COUNT

The transistor count for ICS840001-31 is: 2805

EEPW 电子产品世界 .com.cn



Integrated
Circuit
Systems, Inc.

PRELIMINARY

ICS840001-31
FEMTOCLOCKS™ CRYSTAL-TO-
LVCMOS/LVTTL FREQUENCY SYNTHESIZER

PACKAGE OUTLINE - K SUFFIX FOR 16 LEAD VFQFN

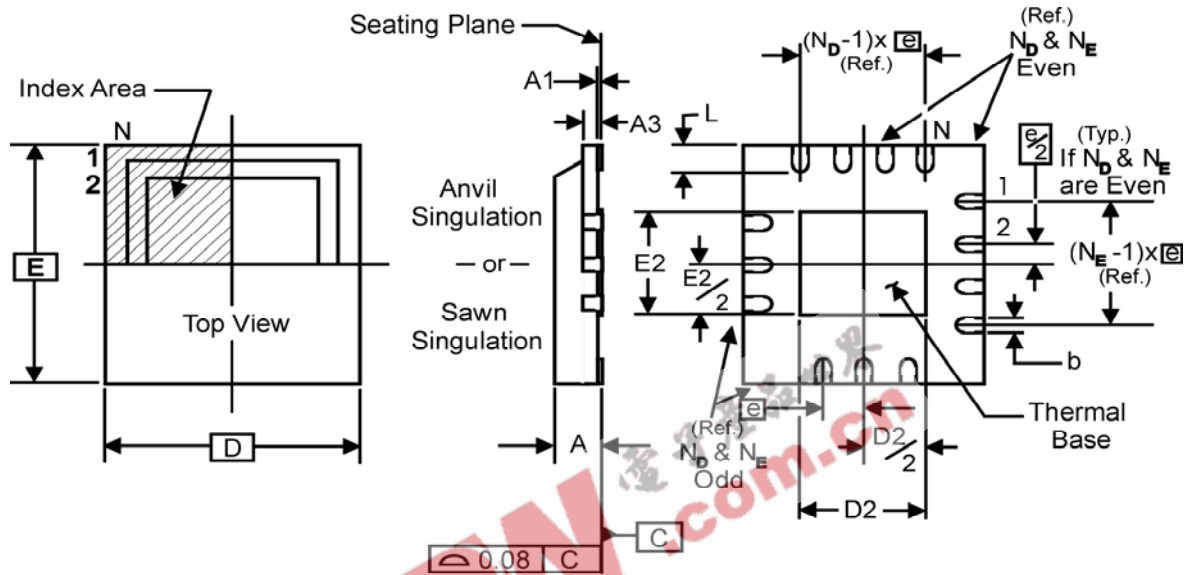

TABLE 8. PACKAGE DIMENSIONS

JEDEC VARIATION ALL DIMENSIONS IN MILLIMETERS		
SYMBOL	MINIMUM	MAXIMUM
N	16	
A	0.80	1.0
A1	0	0.05
A3	0.25 Reference	
b	0.18	0.30
e	0.50 BASIC	
N _D	4	
N _E	4	
D	3.0	
D2	0.25	1.25
E	3.0	
E2	0.25	1.25
L	0.30	0.50

Reference Document: JEDEC Publication 95, MO-220



Integrated
Circuit
Systems, Inc.

PRELIMINARY

ICS840001-31
FEMTOCLOCKS™ CRYSTAL-TO-
LVCMOS/LVTTL FREQUENCY SYNTHESIZER

TABLE 9. ORDERING INFORMATION

Part/Order Number	Marking	Package	Shipping Packaging	Temperature
ICS840001AK-31	1A31	16 Lead VFQFN	tray	0°C to 70°C
ICS840001AK-31	1A31	16 Lead VFQFN	2500 tape & reel	0°C to 70°C

EEPW 电子产品世界
.com.cn

PCI Express™ is a trademark of PCI-SIG. All trademarks mentioned are the property of their respective owners. The aforementioned trademarks, HiPerClockS™ and FemtoClocks™ are a trademark of Integrated Circuit Systems, Inc. or its subsidiaries in the United States and/or other countries. While the information presented herein has been checked for both accuracy and reliability, Integrated Circuit Systems, Incorporated (ICS) assumes no responsibility for either its use or for infringement of any patents or other rights of third parties, which would result from its use. No other circuits, patents, or licenses are implied. This product is intended for use in normal commercial applications. Any other applications such as those requiring extended temperature range, high reliability or other extraordinary environmental requirements are not recommended without additional processing by ICS. ICS reserves the right to change any circuitry or specifications without notice. ICS does not authorize or warrant any ICS product for use in life support devices or critical medical instruments.