

13-input NAND Gate

FAST 74F133

FAST Products

PRODUCT SPECIFICATION

TYPE	TYPICAL PROPAGATION DELAY	TYPICAL SUPPLY CURRENT (TOTAL)
74F133	4.0ns	2.0 mA

ORDERING INFORMATION

DESCRIPTION	ORDER CODE	
	COMMERCIAL RANGE $V_{CC} = 5V \pm 10\%$, $T_{amb} = 0^{\circ}C \text{ to } +70^{\circ}C$	INDUSTRIAL RANGE $V_{CC} = 5V \pm 10\%$, $T_{amb} = -40^{\circ}C \text{ to } +85^{\circ}C$
16-pin plastic DIP	N74F133N	I74F133N
16-pin plastic SO	N74F133D	I74F133D

INPUT AND OUTPUT LOADING AND FAN OUT TABLE

PINS	DESCRIPTION	74F (U.L.) HIGH/LOW	LOAD VALUE HIGH/LOW
D ₀ - D ₁₂	Data inputs	1.0/1.0	20μA/0.6mA
Q	Data output	50/33	1.0mA/20mA

Note to input and output loading and fan out table

1. One (1.0) FAST unit load is defined as: 20μA in the high state and 0.6mA in the low state.

PIN CONFIGURATION

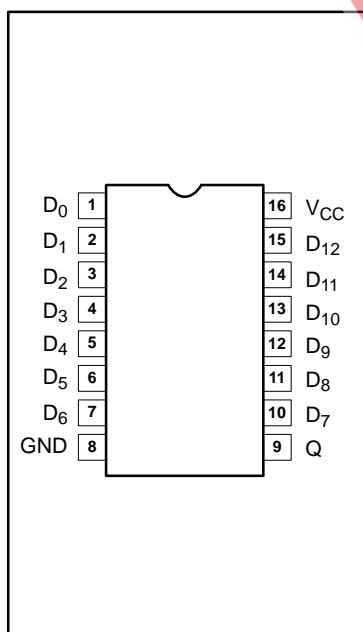

LOGIC SYMBOL

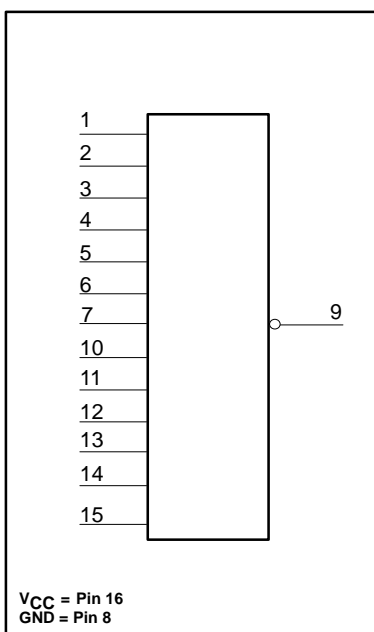

LOGIC SYMBOL (IEEE/IEC)

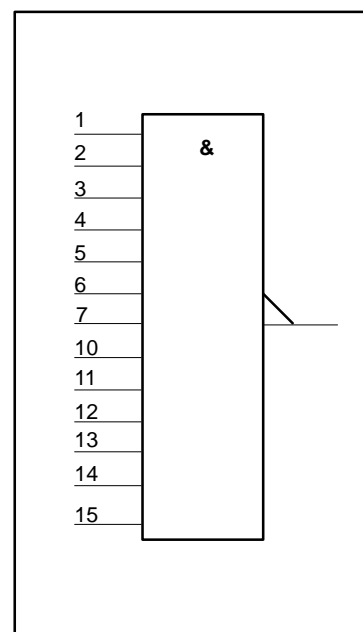

13-input NAND Gate

FAST 74F133

LOGIC DIAGRAM

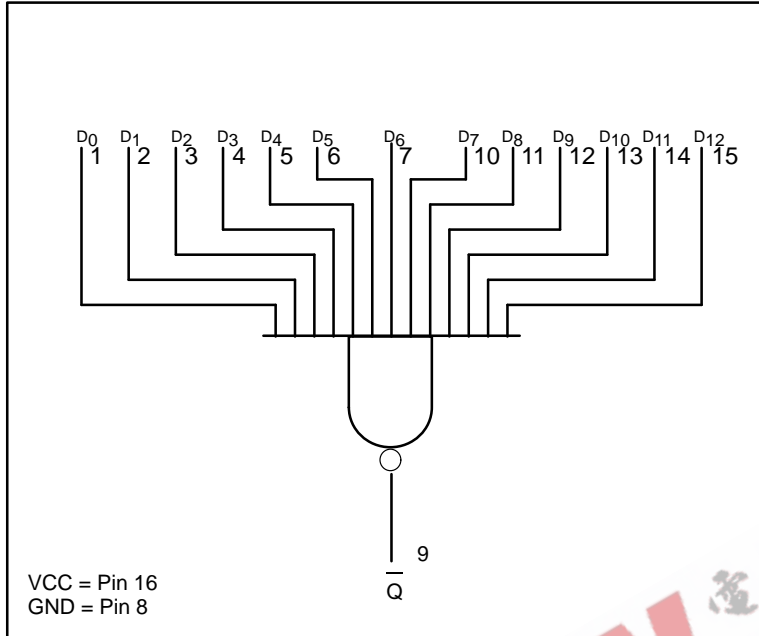

FUNCTION TABLE

INPUTS													OUTPUT
D0	D1	D2	D3	D4	D5	D6	D7	D8	D9	D10	D11	D12	\bar{Q}
H	H	H	H	H	H	H	H	H	H	H	H	H	L
Any one input = L													H

13-input NAND Gate

FAST 74F133

ABSOLUTE MAXIMUM RATINGS

(Operation beyond the limit set forth in this table may impair the useful life of the device. Unless otherwise noted these limits are over the operating free air temperature range.)

SYMBOL	PARAMETER	RATING	UNIT	
V _{CC}	Supply voltage	-0.5 to +7.0	V	
V _{IN}	Input voltage	-0.5 to +7.0	V	
I _{IN}	Input current	-30 to +5	mA	
V _{OUT}	Voltage applied to output in high output state	-0.5 to V _{CC}	V	
I _{OUT}	Current applied to output in low output state	40	mA	
T _{amb}	Operating free air temperature range	Commercial range	0 to +70	°C
		Industrial range	-40 to +85	°C
T _{stg}	Storage temperature range	-65 to +150	°C	

RECOMMENDED OPERATING CONDITIONS

SYMBOL	PARAMETER	LIMITS			UNIT
		MIN	NOM	MAX	
V _{CC}	Supply voltage	4.5	5.0	5.5	V
V _{IH}	High-level input voltage	2.0			V
V _{IL}	Low-level input voltage			0.8	V
I _{IK}	Input clamp current			-18	mA
I _{OH}	High-level output current			-1	mA
I _{OL}	Low-level output current			20	mA
T _{amb}	Operating free air temperature range	Commercial range	0	+70	°C
		Industrial range	-40	+85	°C

DC ELECTRICAL CHARACTERISTICS

(Over recommended operating free-air temperature range unless otherwise noted.)

SYMBOL	PARAMETER	TEST CONDITIONS ¹	LIMITS			UNIT	
			MIN	TYP ²	MAX		
V _{OH}	High-level output voltage	V _{CC} = MIN, V _{IL} = MAX	±10%V _{CC}	2.5		V	
		V _{IH} = MIN, I _{OH} = MAX	±5%V _{CC}	2.7	3.4	V	
V _{OL}	Low-level output voltage	V _{CC} = MIN, V _{IL} = MAX	±10%V _{CC}		0.35	0.50	V
		V _{IH} = MIN, I _{OL} = MAX	±5%V _{CC}		0.35	0.50	V
V _{IK}	Input clamp voltage	V _{CC} = MIN, I _I = I _{IK}			-0.73	-1.2	V
I _I	Input current at maximum input voltage	V _{CC} = MAX, V _I = 7.0V				100	μA
I _{IH}	High-level input current	V _{CC} = MAX, V _I = 2.7V				20	μA
I _{IL}	Low-level input current	V _{CC} = MAX, V _I = 0.5V				-0.6	mA
I _{OS}	Short-circuit output current ³	V _{CC} = MAX		-60		-150	mA
I _{CC}	Supply current (total)	I _{CC} H V _{CC} = MAX			1.0	2.0	mA
		I _{CC} L V _{CC} = MAX			2.5	4.0	mA

NOTES:

- For conditions shown as MIN or MAX, use the appropriate value specified under recommended operating conditions for the applicable type.
- All typical values are at V_{CC} = 5V, T_{amb} = 25°C.
- Not more than one output should be shorted at a time. For testing I_{OS}, the use of high-speed test apparatus and/or sample-and-hold techniques are preferable in order to minimize internal heating and more accurately reflect operational values. Otherwise, prolonged shorting of a high output may raise the chip temperature well above normal and thereby cause invalid readings in other parameter tests. In any sequence of parameter tests, I_{OS} tests should be performed last.

13-input NAND Gate

FAST 74F133

AC ELECTRICAL CHARACTERISTICS

SYMBOL	PARAMETER	TEST CONDITION	LIMITS						UNIT	
			$T_{amb} = +25^{\circ}\text{C}$			$T_{amb} = 0^{\circ}\text{C to } +70^{\circ}\text{C}$		$T_{amb} = -40^{\circ}\text{C to } +85^{\circ}\text{C}$		
			MIN	TYP	MAX	MIN	MAX	MIN		MAX
t_{PLH} t_{PHL}	Propagation delay Dn to \bar{Q} n	Waveform 1	$V_{CC} = +5.0\text{V}$ $C_L = 50\text{pF}$ $R_L = 500\Omega$			$V_{CC} = +5.0\text{V} \pm 10\%$ $C_L = 50\text{pF}$ $R_L = 500\Omega$		$V_{CC} = +5.0\text{V} \pm 10\%$ $C_L = 50\text{pF}$ $R_L = 500\Omega$		ns
			2.0	4.0	7.0	1.5	7.5	1.5	7.5	
			2.5	4.5	7.5	2.0	8.0	2.0	8.0	

AC WAVEFORMS

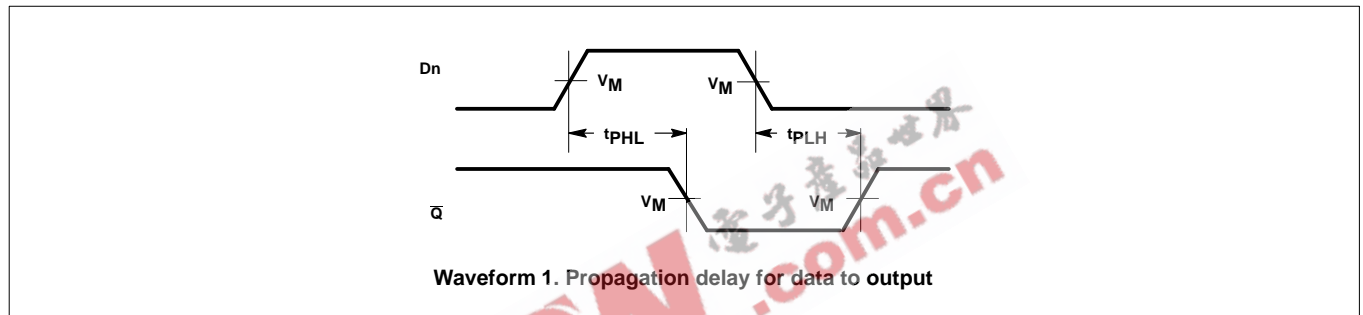

Note to AC Waveforms

1. For all waveforms, $V_M = 1.5\text{V}$.

TEST CIRCUIT AND WAVEFORMS

Test circuit for totem-pole outputs

Input pulse definition

DEFINITIONS:

- R_L = Load resistor; see AC electrical characteristics for value.
- C_L = Load capacitance includes jig and probe capacitance; see AC electrical characteristics for value.
- R_T = Termination resistance should be equal to Z_{OUT} of pulse generators.

family	INPUT PULSE REQUIREMENTS					
	amplitude	V_M	rep. rate	t_w	t_{TLH}	t_{THL}
74F	3.0V	1.5V	1MHz	500ns	2.5ns	2.5ns