



# FEMTOCLOCKS™ VCXO BASED WCDMA CLOCK GENERATOR/JITTER ATTENUATOR

ICS843002I-72

## GENERAL DESCRIPTION

The ICS843002I-72 is a member of the HiPerClockS™ family of high performance clock solutions from IDT. The ICS843002I-72 is a PLL based synchronous clock generator that is optimized for WCDMA channel card applications where jitter attenuation and frequency translation is needed. The device contains two internal PLL stages that are cascaded in series. The first PLL stage uses a VCXO which is optimized to provide reference clock jitter attenuation and to be jitter tolerant, and to provide a stable reference clock for the second PLL stage. The second PLL stage provides additional frequency multiplication (x32), and it maintains low output jitter by using a low phase noise FemtoClock™ VCO. The device performance and the PLL multiplication ratios are optimized to support WCDMA applications. The VCXO requires the use of an external, inexpensive pullable crystal. VCXO PLL uses external passive loop filter components which are used to optimize the PLL loop bandwidth and damping characteristics for the given application.

The ICS843002I-72 can accept a single-ended input. LOCK\_DT reports the lock status of VCXO PLL loop. If the reference clock input is lost, it will set LOCK\_DT to logic LOW.

Typical ICS843002I-72 configuration in WCDMA Systems:

- 19.2MHz pullable crystal
- Input Reference clock frequency: 3.84MHz
- Output clock frequency: 122.88MHz

## FEATURES

- Two differential LVPECL outputs
- CLK input accepts the following input levels: LVCMOS or LVTTTL levels
- Output frequency: 122.88MHz (typical)
- FemtoClock VCO frequency range: 490MHz - 680MHz
- RMS phase jitter @ 122.88MHz, using a 19.2MHz crystal (1.875MHz to 10MHz): 0.49ps (typical)
- Deterministic jitter: 30fs (typical)
- Random jitter, RMS: 2.2ps (typical)
- Full 3.3V or mixed 3.3V core/2.5V output supply voltage
- -40°C to 85°C ambient operating temperature
- Available in lead-free (RoHS 6) package

## PIN ASSIGNMENT

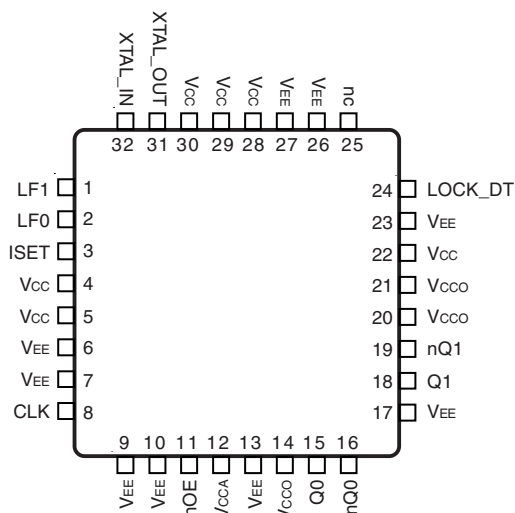

### ICS843002I-72

32-Lead VFQFN

5mm x 5mm x 0.925 package body

K Package

Top View

## BLOCK DIAGRAM

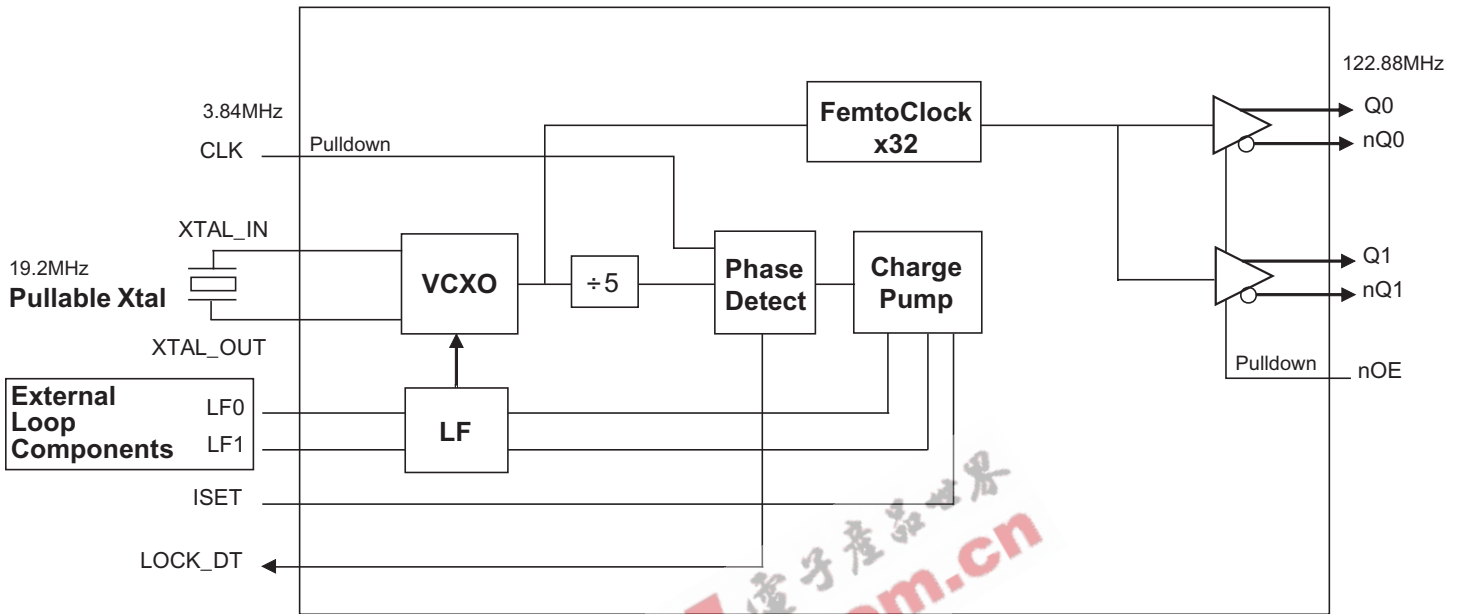

NOTE 1: 19.2MHz pullable crystal shown is typical for WCDMA device applications.

TABLE 1. PIN DESCRIPTIONS

Number	Name	Type		Description
1, 2	LF1, LF0	Analog Input/Output		Loop filter connection node pins.
3	ISET	Analog Input/Output		Charge pump current setting pin.
4, 5, 22, 28, 29, 30	V <sub>CC</sub>	Power		Core power supply pins.
6, 7, 9, 10, 13, 17, 23, 26, 27	V <sub>EE</sub>	Power		Negative supply pins.
8	CLK	Input	Pulldown	Single-ended clock input. LVCMOS/LVTTL interface levels.
11	nOE	Input	Pulldown	Output enable pin. When LOW, output is enabled. LVCMOS/LVTTL interface levels. See Table 3.
12	V <sub>CCA</sub>	Power		Analog supply pin.
14, 20, 21	V <sub>CCO</sub>	Power		Output power supply pin.
15, 16	Q0, nQ0	Output		Differential clock output pair. LVPECL interface levels.
18, 19	Q1, nQ1	Output		Differential clock output pair. LVPECL interface levels.
24	LOCK_DT	Output		Lock detect. Logic HIGH when VCXO PLL loop is locked.
25	nc	Unused		No connect.
31, 32	XTAL_OUT, XTAL_IN	Input		Crystal oscillator interface. XTAL_OUT is the output. XTAL_IN is the input.

NOTE: *Pulldown* refers to internal input resistors. See Table 2, Pin Characteristics, for typical values.

TABLE 2. PIN CHARACTERISTICS

Symbol	Parameter	Test Conditions	Minimum	Typical	Maximum	Units
C <sub>IN</sub>	Input Capacitance			4		pF
R <sub>PULLDOWN</sub>	Input Pulldown Resistor			50		kΩ

TABLE 3. INPUT REFERENCE SELECTION FUNCTION TABLE

Inputs	Outputs
nOE	Q0/nQ0, Q1/nQ1
0	Enabled
1	Hi-Z

## ABSOLUTE MAXIMUM RATINGS

Supply Voltage, $V_{CC}$	4.6V
Inputs, $V_I$	-0.5V to $V_{CC} + 0.5V$
Outputs, $I_O$ (LVPECL)	
Continuous Current	50mA
Surge Current	100mA
Package Thermal Impedance, $\theta_{JA}$	37°C/W (0 mps)
Storage Temperature, $T_{STG}$	-65°C to 150°C

NOTE: Stresses beyond those listed under Absolute Maximum Ratings may cause permanent damage to the device. These ratings are stress specifications only. Functional operation of product at these conditions or any conditions beyond those listed in the *DC Characteristics* or *AC Characteristics* is not implied. Exposure to absolute maximum rating conditions for extended periods may affect product reliability.

TABLE 4A. POWER SUPPLY DC CHARACTERISTICS,  $V_{CC} = V_{CCO} = 3.3V \pm 5\%$ ,  $V_{EE} = 0V$ ,  $T_A = -40^\circ C$  TO  $85^\circ C$ 

Symbol	Parameter	Test Conditions	Minimum	Typical	Maximum	Units
$V_{CC}$	Core Supply Voltage		3.135	3.3	3.465	V
$V_{CCA}$	Analog Supply Voltage		$V_{CC} - 0.13$	3.3	$V_{CC}$	V
$V_{CCO}$	Output Supply Voltage		3.135	3.3	3.465	V
$I_{EE}$	Power Supply Current				140	mA
$I_{CCA}$	Analog Supply Current				13	mA

TABLE 4B. POWER SUPPLY DC CHARACTERISTICS,  $V_{CC} = 3.3V \pm 5\%$ ,  $V_{CCO} = 2.5V \pm 5\%$ ,  $V_{EE} = 0V$ ,  $T_A = -40^\circ C$  TO  $85^\circ C$ 

Symbol	Parameter	Test Conditions	Minimum	Typical	Maximum	Units
$V_{CC}$	Core Supply Voltage		3.135	3.3	3.465	V
$V_{CCA}$	Analog Supply Voltage		$V_{CC} - 0.13$	3.3	$V_{CC}$	V
$V_{CCO}$	Output Supply Voltage		2.375	2.5	2.625	V
$I_{EE}$	Power Supply Current				140	mA
$I_{CCA}$	Analog Supply Current				13	mA

TABLE 4C. LVCMOS / LVTTTL DC CHARACTERISTICS,  $V_{CC} = 3.3V \pm 5\%$ ,  $V_{CCO} = 3.3V \pm 5\%$  OR  $2.5V \pm 5\%$ ,  $V_{EE} = 0V$ ,  $T_A = -40^\circ C$  TO  $85^\circ C$ 

Symbol	Parameter	Test Conditions	Minimum	Typical	Maximum	Units
$V_{IH}$	Input High Voltage		2		$V_{CC} + 0.3$	V
$V_{IL}$	Input Low Voltage		-0.3		0.8	V
$I_{IH}$	Input High Current	CLK, nOE $V_{CC} = V_{IN} = 3.465V$			150	$\mu A$
$I_{IL}$	Input Low Current	CLK, nOE $V_{CC} = 3.465V, V_{IN} = 0V$	-5			$\mu A$

TABLE 4D. LVPECL DC CHARACTERISTICS,  $V_{CC} = V_{CCO} = 3.3V \pm 5\%$ ,  $V_{EE} = 0V$ ,  $T_A = -40^\circ C$  TO  $85^\circ C$ 

Symbol	Parameter	Test Conditions	Minimum	Typical	Maximum	Units
$V_{OH}$	Output High Voltage; NOTE 1		$V_{CCO} - 1.4$		$V_{CCO} - 0.9$	V
$V_{OL}$	Output Low Voltage; NOTE 1		$V_{CCO} - 2.0$		$V_{CCO} - 1.7$	V
$V_{SWING}$	Peak-to-Peak Output Voltage Swing		0.6		1.0	V

NOTE 1: Outputs terminated with 50  $\Omega$  to  $V_{CCO} - 2V$ . See "Parameter Measurement Information" section, "Output Load Test Circuit" diagrams.

TABLE 4E. LVPECL DC CHARACTERISTICS,  $V_{CC} = 3.3V \pm 5\%$ ,  $V_{CCO} = 2.5V \pm 5\%$ ,  $V_{EE} = 0V$ ,  $T_A = -40^\circ C$  TO  $85^\circ C$ 

Symbol	Parameter	Test Conditions	Minimum	Typical	Maximum	Units
$V_{OH}$	Output High Voltage; NOTE 1		$V_{CCO} - 1.4$		$V_{CCO} - 0.9$	V
$V_{OL}$	Output Low Voltage; NOTE 1		$V_{CCO} - 2.0$		$V_{CCO} - 1.5$	V
$V_{SWING}$	Peak-to-Peak Output Voltage Swing		0.4		1.0	V

NOTE 1: Outputs terminated with  $50 \Omega$  to  $V_{CCO} - 2V$ . See "Parameter Measurement Information" section, "Output Load Test Circuit" diagrams.

TABLE 5A. AC CHARACTERISTICS,  $V_{CC} = V_{CCO} = 3.3V \pm 5\%$ ,  $V_{EE} = 0V$ ,  $T_A = -40^\circ C$  TO  $85^\circ C$ 

Symbol	Parameter	Test Conditions	Minimum	Typical	Maximum	Units
$F_{OUT}$	Output Frequency			122.88		MHz
$f_{jit}(\theta)$	RMS Phase Jitter, (Random); NOTE 1	122.88MHz, Integration range: 1.875MHz - 10MHz		0.49		ps
$t_{DJ}$	Deterministic Jitter; NOTE 2			30		fs
$t_{RJ}$	Random Jitter, RMS; NOTE 2			2.2		ps
$t_{sk}(o)$	Output Skew; NOTE 3, 4				50	ps
$t_R / t_F$	Output Rise/Fall Time	20% to 80%	300		550	ps
odc	Output Duty Cycle		49		51	%

See Parameter Measurement Information section.

NOTE 1: Please refer to the Phase Noise Plot.

NOTE 2: Measured using Wavcrest SIA-3000.

NOTE 3: Defined as skew between outputs at the same supply voltage and with equal load conditions.

Measured at the output differential cross points.

NOTE 4: This parameter is defined in accordance with JEDEC Standard 65.

TABLE 5B. AC CHARACTERISTICS,  $V_{CC} = 3.3V \pm 5\%$ ,  $V_{CCO} = 2.5V \pm 5\%$ ,  $V_{EE} = 0V$ ,  $T_A = -40^\circ C$  TO  $85^\circ C$ 

Symbol	Parameter	Test Conditions	Minimum	Typical	Maximum	Units
$F_{OUT}$	Output Frequency			122.88		MHz
$f_{jit}(\theta)$	RMS Phase Jitter, (Random); NOTE 1	122.88MHz, Integration range: 1.875MHz - 10MHz		0.49		ps
$t_{DJ}$	Deterministic Jitter; NOTE 2			30		fs
$t_{RJ}$	Random Jitter, RMS; NOTE 2			2.2		ps
$t_{sk}(o)$	Output Skew; NOTE 3, 4				50	ps
$t_R / t_F$	Output Rise/Fall Time	20% to 80%	300		550	ps
odc	Output Duty Cycle		49		51	%

See Parameter Measurement Information section.

NOTE 1: Please refer to the Phase Noise Plot.

NOTE 2: Measured using Wavcrest SIA-3000.

NOTE 3: Defined as skew between outputs at the same supply voltage and with equal load conditions.

Measured at the output differential cross points.

NOTE 4: This parameter is defined in accordance with JEDEC Standard 65.

TYPICAL PHASE NOISE AT 122.88MHz @ 3.3V/3.3V

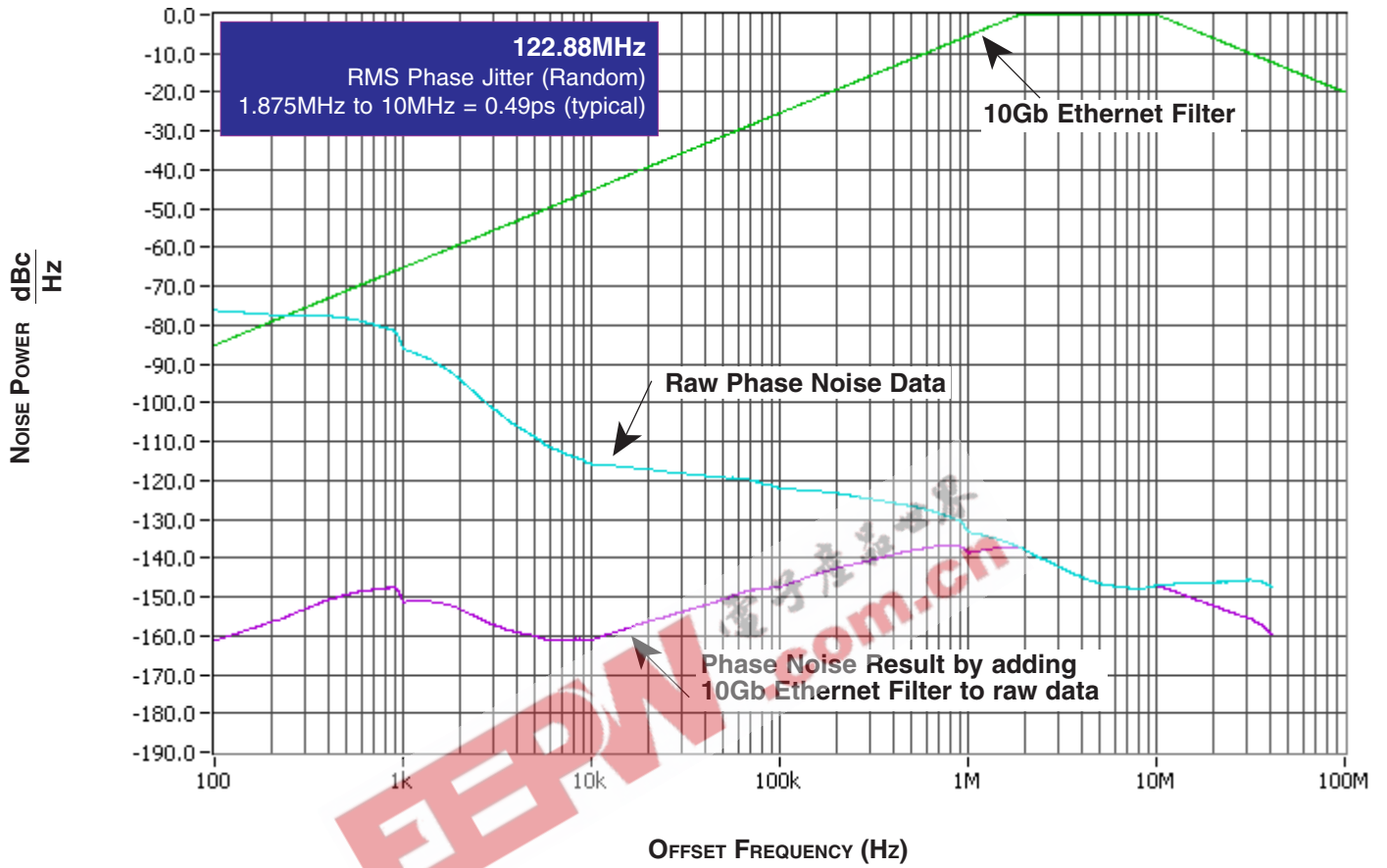

## PARAMETER MEASUREMENT INFORMATION

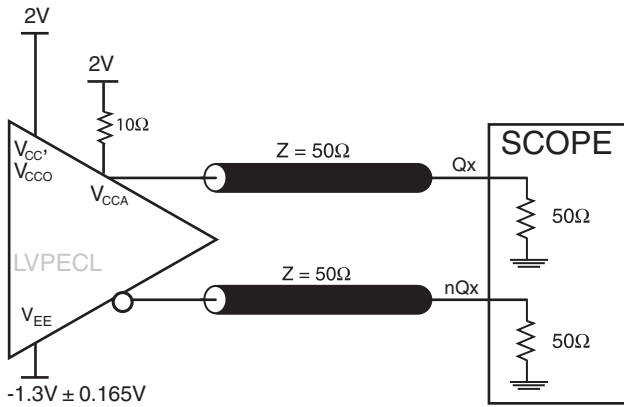

3.3V CORE/3.3V LVPECL OUTPUT LOAD AC TEST CIRCUIT

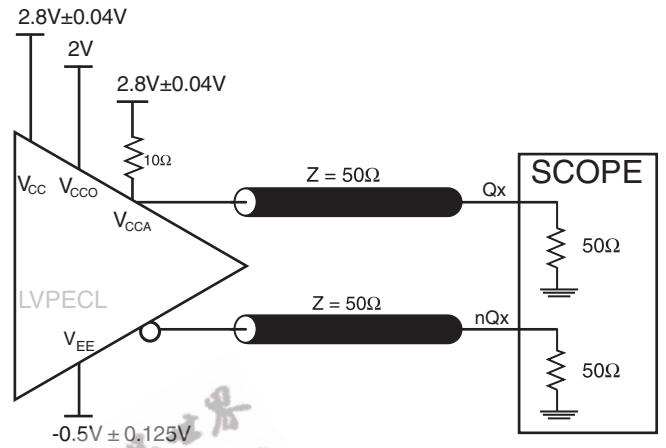

3.3V CORE/2.5V LVPECL OUTPUT LOAD AC TEST CIRCUIT

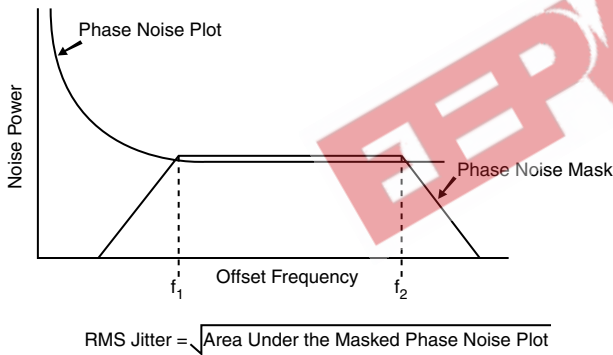

PHASE JITTER

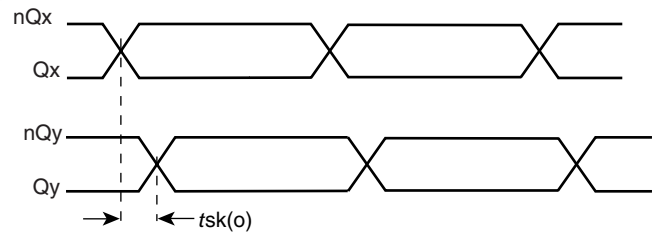

OUTPUT SKEW

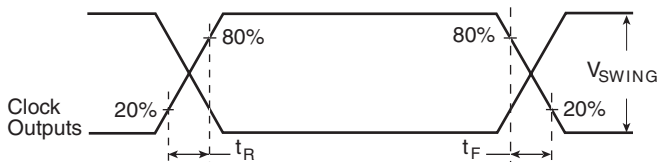

OUTPUT RISE/FALL TIME

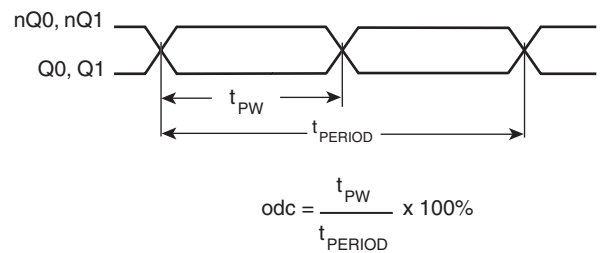

OUTPUT DUTY CYCLE/PULSE WIDTH/tPERIOD

## APPLICATION INFORMATION

### POWER SUPPLY FILTERING TECHNIQUES

As in any high speed analog circuitry, the power supply pins are vulnerable to random noise. To achieve optimum jitter performance, power supply isolation is required. The ICS843002I-72 provides separate power supplies to isolate any high switching noise from the outputs to the internal PLL.  $V_{CC}$ ,  $V_{CCA}$ , and  $V_{CCO}$  should be individually connected to the power supply plane through vias, and  $0.01\mu\text{F}$  bypass capacitors should be used for each pin. *Figure 1* illustrates this for a generic  $V_{CC}$  pin and also shows that  $V_{CCA}$  requires that an additional  $10\Omega$  resistor along with a  $10\mu\text{F}$  bypass capacitor be connected to the  $V_{CCA}$  pin.

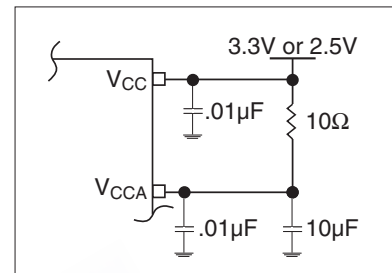

FIGURE 1. POWER SUPPLY FILTERING

### TERMINATION FOR 3.3V LVPECL OUTPUTS

The clock layout topology shown below is a typical termination for LVPECL outputs. The two different layouts mentioned are recommended only as guidelines.

FOUT and nFOUT are low impedance follower outputs that generate ECL/LVPECL compatible outputs. Therefore, terminating resistors (DC current path to ground) or current sources must be used for functionality. These outputs are designed to drive  $50\Omega$

transmission lines. Matched impedance techniques should be used to maximize operating frequency and minimize signal distortion. *Figures 2A and 2B* show two different layouts which are recommended only as guidelines. Other suitable clock layouts may exist and it would be recommended that the board designers simulate to guarantee compatibility across all printed circuit and clock component process variations.

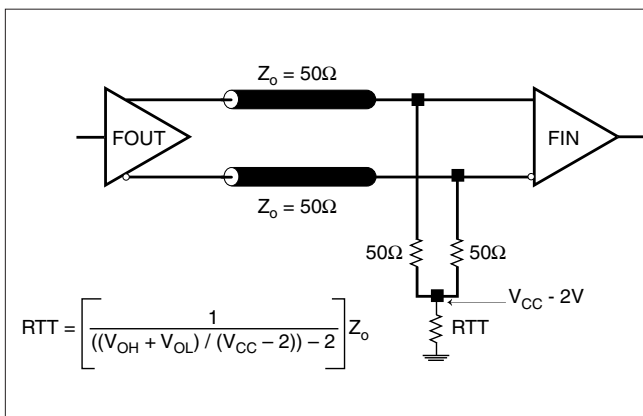

FIGURE 2A. LVPECL OUTPUT TERMINATION

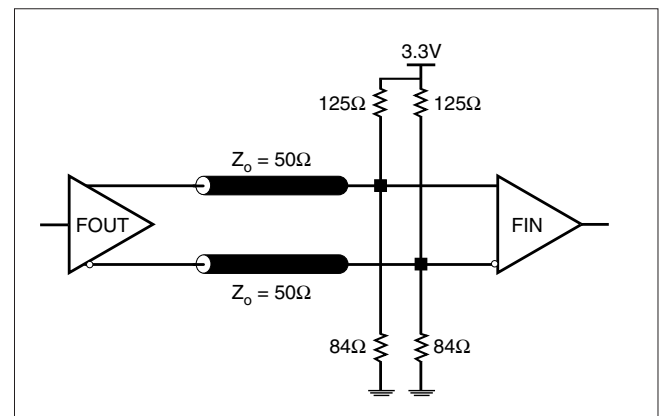

FIGURE 2B. LVPECL OUTPUT TERMINATION



### TERMINATION FOR 2.5V LVPECL OUTPUT

Figure 3A and Figure 5B show examples of termination for 2.5V LVPECL driver. These terminations are equivalent to terminating 50Ω to  $V_{CC} - 2V$ . For  $V_{CC} = 2.5V$ , the  $V_{CC} - 2V$  is very close to ground

level. The R3 in Figure 5B can be eliminated and the termination is shown in Figure 5C.

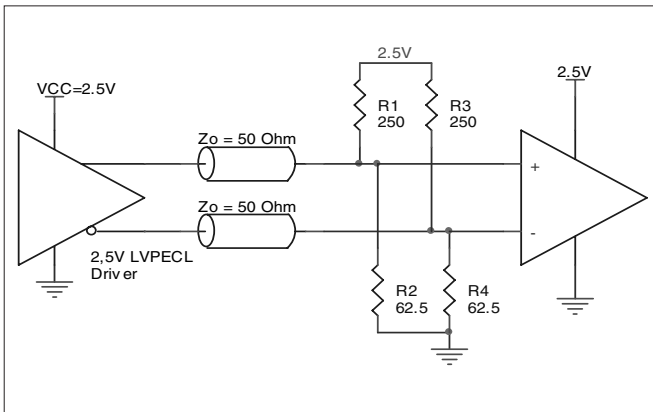

FIGURE 3A. 2.5V LVPECL DRIVER TERMINATION EXAMPLE

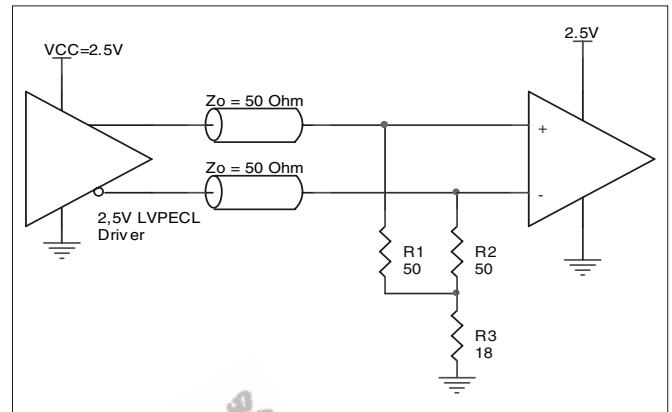

FIGURE 3B. 2.5V LVPECL DRIVER TERMINATION EXAMPLE

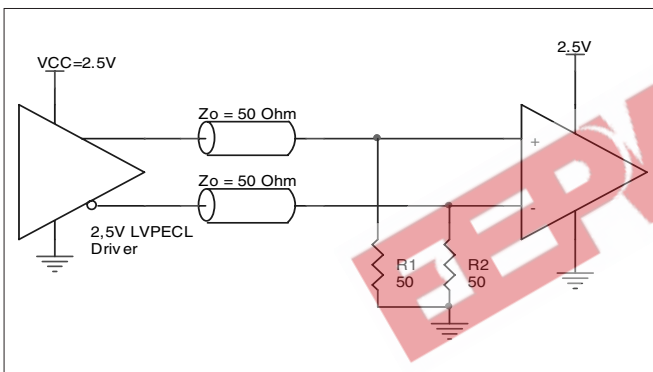

FIGURE 3C. 2.5V LVPECL TERMINATION EXAMPLE

### RECOMMENDATIONS FOR UNUSED INPUT AND OUTPUT PINS

#### INPUTS:

##### LVC MOS CONTROL PINS

All control pins have internal pull-ups or pull-downs; additional resistance is not required but can be added for additional protection. A 1kΩ resistor can be used.

#### OUTPUTS:

##### LVPECL OUTPUTS

All unused LVPECL outputs can be left floating. We recommend that there is no trace attached. Both sides of the differential output pair should either be left floating or terminated.

### VFQFN EPAD THERMAL RELEASE PATH

In order to maximize both the removal of heat from the package and the electrical performance, a land pattern must be incorporated on the Printed Circuit Board (PCB) within the footprint of the package corresponding to the exposed metal pad or exposed heat slug on the package, as shown in *Figure 4*. The solderable area on the PCB, as defined by the solder mask, should be at least the same size/shape as the exposed pad/slug area on the package to maximize the thermal/electrical performance. Sufficient clearance should be designed on the PCB between the outer edges of the land pattern and the inner edges of pad pattern for the leads to avoid any shorts.

While the land pattern on the PCB provides a means of heat transfer and electrical grounding from the package to the board through a solder joint, thermal vias are necessary to effectively conduct from the surface of the PCB to the ground plane(s). The land pattern must be connected to ground through these vias. The vias act as “heat pipes”. The number of vias (i.e. “heat pipes”)

are application specific and dependent upon the package power dissipation as well as electrical conductivity requirements. Thus, thermal and electrical analysis and/or testing are recommended to determine the minimum number needed. Maximum thermal and electrical performance is achieved when an array of vias is incorporated in the land pattern. It is recommended to use as many vias connected to ground as possible. It is also recommended that the via diameter should be 12 to 13mils (0.30 to 0.33mm) with 1oz copper via barrel plating. This is desirable to avoid any solder wicking inside the via during the soldering process which may result in voids in solder between the exposed pad/slug and the thermal land. Precautions should be taken to eliminate any solder voids between the exposed heat slug and the land pattern. Note: These recommendations are to be used as a guideline only. For further information, refer to the Application Note on the *Surface Mount Assembly* of Amkor's Thermally/Electrically Enhance Leadframe Base Package, Amkor Technology.

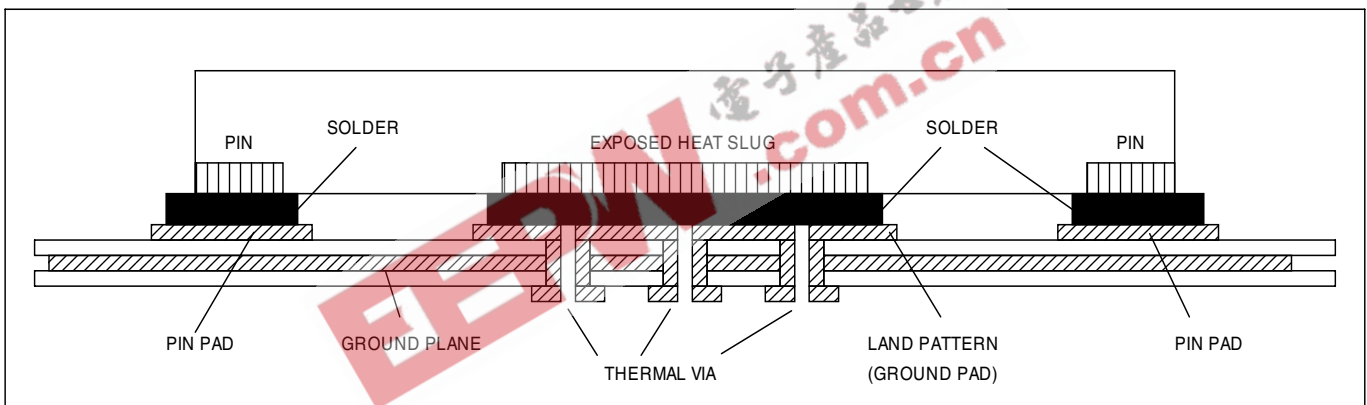

**FIGURE 4. P.C.ASSEMBLY FOR EXPOSED PAD THERMAL RELEASE PATH –SIDE VIEW (DRAWING NOT TO SCALE)**

LAYOUT GUIDELINE

Figure 5 shows an example of ICS843002I-72 application schematic. In this example, the device is operated at  $V_{CC} = 3.3V$ . The 19.2MHz pullable crystal is used. The bypass capacitor should be placed as close as possible to the power pins. Two

examples of LVPECL terminations are shown in this schematic. Additional termination approaches are shown in the LVPECL Termination Application Note.

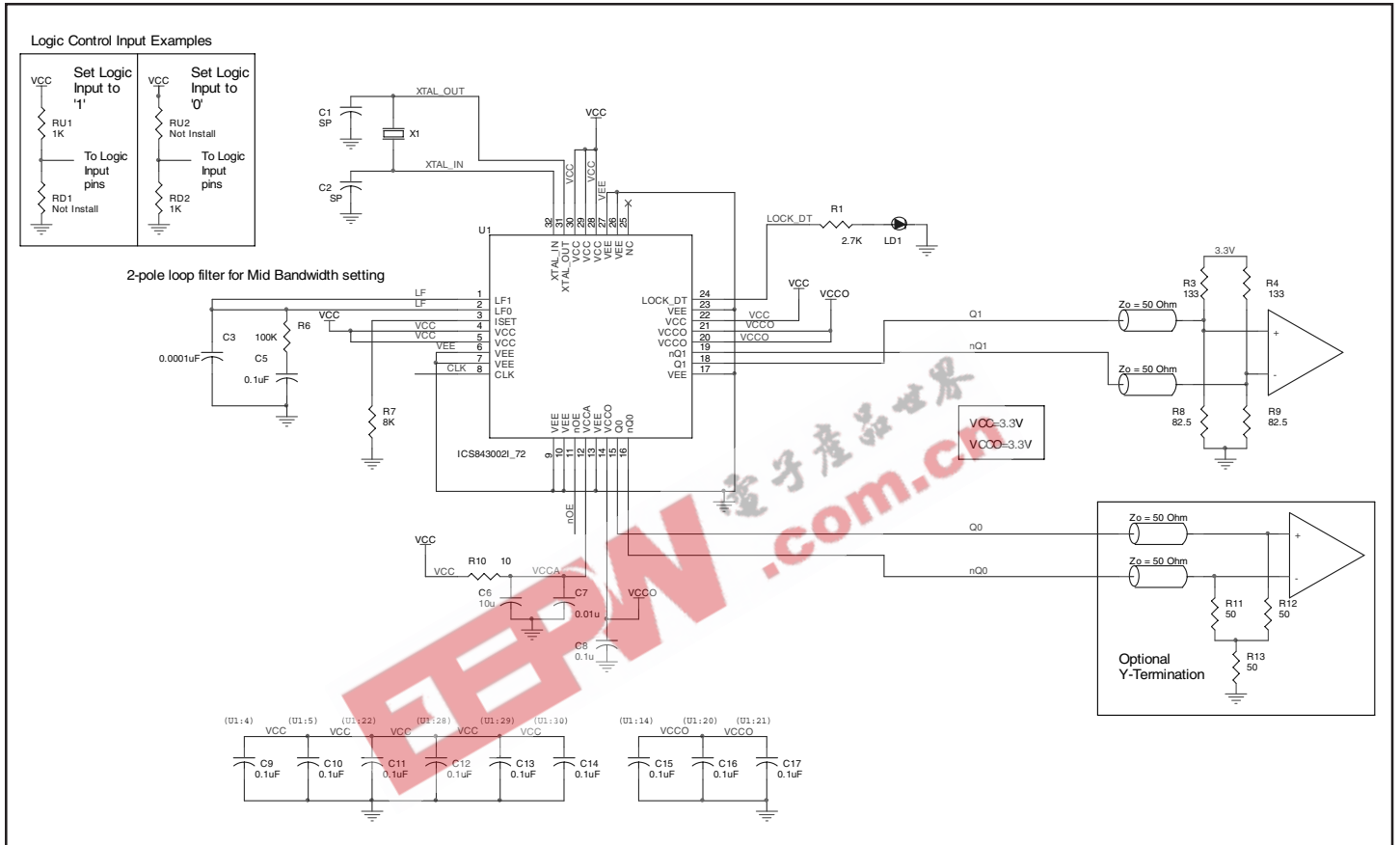

FIGURE 5. SCHEMATIC OF RECOMMENDED LAYOUT

## VCXO-PLL EXTERNAL COMPONENTS

Choosing the correct external components and having a proper printed circuit board (PCB) layout is a key task for quality operation of the VCXO-PLL. In choosing a crystal, special precaution must be taken with the package and load capacitance ( $C_L$ ). In addition, frequency, accuracy and temperature range must also be considered. Since the pulling range of a crystal also varies with the package, it is recommended that a metal-canned package like HC49 be used. Generally, a metal-canned package has a larger pulling range than a surface mounted device (SMD). For crystal selection information, refer to the *VCXO Crystal Selection Application Note*.

The crystal's load capacitance  $C_L$  characteristic determines its resonating frequency and is closely related to the VCXO tuning range. The total external capacitance seen by the crystal when installed on a board is the sum of the stray board capacitance, IC package lead capacitance, internal varactor capacitance and any installed tuning capacitors ( $C_{TUNE}$ ).

If the crystal's  $C_L$  is greater than the total external capacitance, the VCXO will oscillate at a higher frequency than the crystal specification. If the crystal's  $C_L$  is lower than the total external capacitance, the VCXO will oscillate at a lower frequency than

the crystal specification. In either case, the absolute tuning range is reduced. The correct value of  $C_L$  is dependent on the characteristics of the VCXO. The recommended  $C_L$  in the Crystal Parameter Table balances the tuning range by centering the tuning curve.

The *VCXO-PLL Loop Bandwidth Selection Table* shows  $R_s$ ,  $C_s$  and  $C_p$  values for recommended high, mid and low loop bandwidth configurations. The device has been characterized using these parameters. For other configurations, refer to the *Loop Filter Component Selection for VCXO Based PLLs Application Note*.

The crystal and external loop filter components should be kept as close as possible to the device. Loop filter and crystal traces should be kept short and separated from each other. Other signal traces should be kept separate and not run underneath the device, loop filter or crystal components.

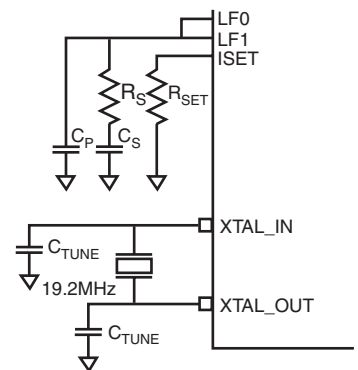

### VCXO CHARACTERISTICS TABLE

Symbol	Parameter	Typical	Unit
$k_{VCXO}$	VCXO Gain	7.8	kHz/V
$C_{V\_LOW}$	Low Varactor Capacitance	2	pF
$C_{V\_HIGH}$	High Varactor Capacitance	8	pF

### VCXO-PLL APPROXIMATE LOOP BANDWIDTH SELECTION TABLE

Bandwidth	Crystal Frequency (MHz)	$R_s$ (k $\Omega$ )	$C_s$ ( $\mu$ F)	$C_p$ ( $\mu$ F)	$R_{SET}$ (k $\Omega$ )
75Hz (Low)	19.2MHz	15	1.0	0.01	8
500Hz (Mid)	19.2MHz	100	0.1	0.0001	8
1kHz (High)	19.2MHz	100	0.1	0.0001	4

### CRYSTAL CHARACTERISTICS

Symbol	Parameter	Minimum	Typical	Maximum	Units
	Mode of Operation	Fundamental			
$f_N$	Frequency		19.2		MHz
$f_T$	Frequency Tolerance			$\pm 20$	ppm
$f_s$	Frequency Stability			$\pm 20$	ppm
	Operating Temperature Range	-40		85	$^{\circ}$ C
$C_L$	Load Capacitance		12		pF
$C_o$	Shunt Capacitance		4		pF
$C_o/C_1$	Pullability Ratio		220	240	
ESR	Equivalent Series Resistance			20	$\Omega$
	Drive Level			1	mW
	Aging @ 25 $^{\circ}$ C			$\pm 3$ per year	ppm

## POWER CONSIDERATIONS

This section provides information on power dissipation and junction temperature for the ICS843002I-72. Equations and example calculations are also provided.

### 1. Power Dissipation.

The total power dissipation for the ICS843002I-72 is the sum of the core power plus the power dissipated in the load(s). The following is the power dissipation for  $V_{CC} = 3.3V + 5\% = 3.465V$ , which gives worst case results.

**NOTE:** Please refer to Section 3 for details on calculating power dissipated in the load.

- Power (core)<sub>MAX</sub> =  $V_{CC\_MAX} * I_{EE\_MAX} = 3.465V * 140mA = 485.15mW$

- Power (outputs)<sub>MAX</sub> = **30mW/Loaded Output pair**

If all outputs are loaded, the total power is  $2 * 30mW = 60mW$

**Total Power**<sub>MAX</sub> (3.465V, with all outputs switching) =  $485.1mW + 60mW = 545.1mW$

### 2. Junction Temperature.

Junction temperature,  $T_j$ , is the temperature at the junction of the bond wire and bond pad and directly affects the reliability of the device. The maximum recommended junction temperature for HiPerClockS™ devices is 125°C.

The equation for  $T_j$  is as follows:  $T_j = \theta_{JA} * Pd\_total + T_A$

$T_j$  = Junction Temperature

$\theta_{JA}$  = Junction-to-Ambient Thermal Resistance

$Pd\_total$  = Total Device Power Dissipation (example calculation is in section 1 above)

$T_A$  = Ambient Temperature

In order to calculate junction temperature, the appropriate junction-to-ambient thermal resistance  $\theta_{JA}$  must be used. Assuming no air flow and a multi-layer board, the appropriate value is 37°C/W per Table 6 below.

Therefore,  $T_j$  for an ambient temperature of 85°C with all outputs switching is:

$$85^\circ C + 0.541W * 37^\circ C/W = 105.1^\circ C. \text{ This is well below the limit of } 125^\circ C.$$

This calculation is only an example.  $T_j$  will obviously vary depending on the number of loaded outputs, supply voltage, air flow, and the type of board (single layer or multi-layer).

**TABLE 6. THERMAL RESISTANCE  $\theta_{JA}$  FOR 32-PIN VFQFN, FORCED CONVECTION**

$\theta_{JA}$ vs. Air Flow (Meters per Second)			
	0	1	2.5
Multi-Layer PCB, JEDEC Standard Test Boards	37.0°C/W	32.4°C/W	29.0°C/W

### 3. Calculations and Equations.

The purpose of this section is to derive the power dissipated into the load.

LVPECL output driver circuit and termination are shown in *Figure 6*.

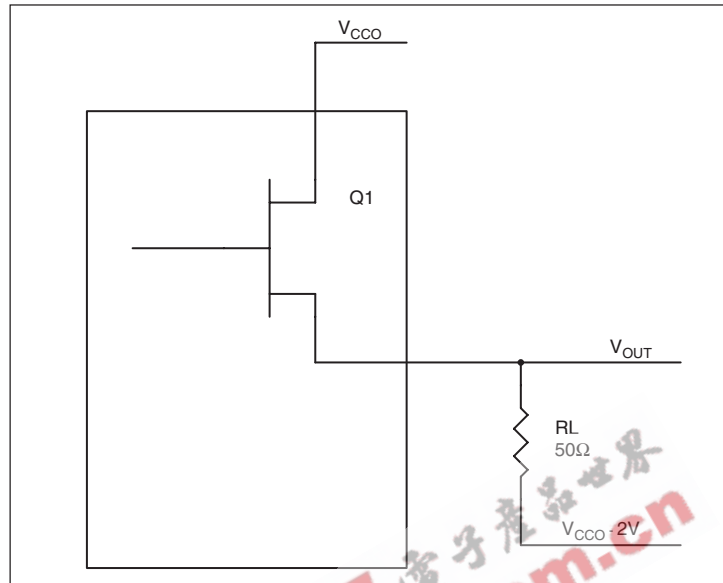

**FIGURE 6. LVPECL DRIVER CIRCUIT AND TERMINATION**

To calculate worst case power dissipation into the load, use the following equations which assume a 50Ω load, and a termination voltage of  $V_{CCO} - 2V$ .

- For logic high,  $V_{OUT} = V_{OH\_MAX} = V_{CCO\_MAX} - 0.9V$

$$(V_{CCO\_MAX} - V_{OH\_MAX}) = 0.9V$$

- For logic low,  $V_{OUT} = V_{OL\_MAX} = V_{CCO\_MAX} - 1.7V$

$$(V_{CCO\_MAX} - V_{OL\_MAX}) = 1.7V$$

Pd<sub>H</sub> is power dissipation when the output drives high.

Pd<sub>L</sub> is the power dissipation when the output drives low.

$$Pd_H = [(V_{OH\_MAX} - (V_{CCO\_MAX} - 2V))/R_L] * (V_{CCO\_MAX} - V_{OH\_MAX}) = [(2V - (V_{CCO\_MAX} - V_{OH\_MAX}))/R_L] * (V_{CCO\_MAX} - V_{OH\_MAX}) = [(2V - 0.9V)/50\Omega] * 0.9V = 19.8mW$$

$$Pd_L = [(V_{OL\_MAX} - (V_{CCO\_MAX} - 2V))/R_L] * (V_{CCO\_MAX} - V_{OL\_MAX}) = [(2V - (V_{CCO\_MAX} - V_{OL\_MAX}))/R_L] * (V_{CCO\_MAX} - V_{OL\_MAX}) = [(2V - 1.7V)/50\Omega] * 1.7V = 10.2mW$$

Total Power Dissipation per output pair = Pd<sub>H</sub> + Pd<sub>L</sub> = 30mW

## RELIABILITY INFORMATION

TABLE 7.  $\theta_{JA}$  vs. AIR FLOW TABLE FOR 32 LEAD VFQFN

$\theta_{JA}$ vs. Air Flow (Meters per Second)			
	0	1	2.5
Multi-Layer PCB, JEDEC Standard Test Boards	37.0°C/W	32.4°C/W	29.0°C/W

### TRANSISTOR COUNT

The transistor count for ICS843002I-72 is: 3199

EEPW 电子产品世界  
.com.cn

PACKAGE OUTLINE - K SUFFIX FOR 32 LEAD VFQFN

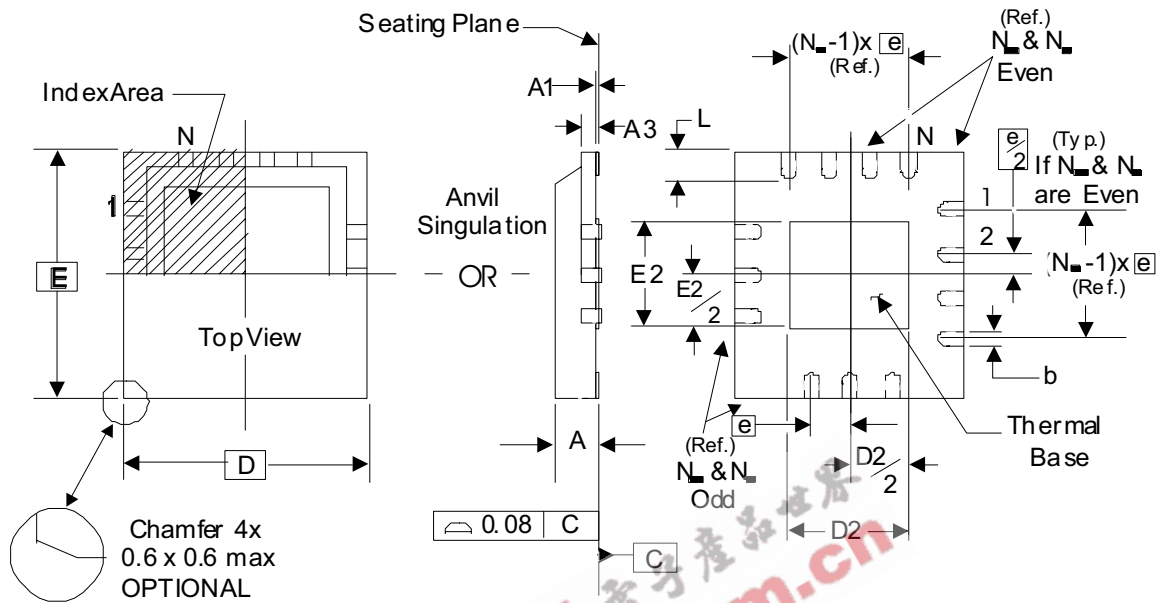

NOTE: The following package mechanical drawing is a generic drawing that applies to any pin count VFQFN package. This drawing is not intended to convey the actual pin count or pin layout of this device. The pin count and pinout are shown on the front page. The package dimensions are in Table 11 below.

TABLE 8. PACKAGE DIMENSIONS

JEDEC VARIATION ALL DIMENSIONS IN MILLIMETERS (VHHD -2/ -4)		
SYMBOL	Minimum	Maximum
N	32	
A	0.80	1.0
A1	0	0.05
A3	0.25 Reference	
b	0.18	0.30
e	0.50 BASIC	
N <sub>b</sub>	8	
N <sub>e</sub>	8	
D, E	5.0 BASIC	
D2, E2	3.0	3.3
L	0.30	0.50

Reference Document: JEDEC Publication 95, MO-220



TABLE 9. ORDERING INFORMATION

Part/Order Number	Marking	Package	Shipping Packaging	Temperature
843002BKI-72LF	ICS002BI72L	32 lead "Lead-Free" VFQFN	tube	-40°C to 85°C
843002BKI-72LFT	ICS002BI72L	32 lead "Lead-Free" VFQFN	2500 tape & reel	-40°C to 85°C

NOTE: Parts that are ordered with an "LF" suffix to the part number are the Pb-Free configuration and are RoHS compliant.

EEPW 电子產品世界  
.com.cn

While the information presented herein has been checked for both accuracy and reliability, Integrated Device Technology, Incorporated (IDT) assumes no responsibility for either its use or for infringement of any patents or other rights of third parties, which would result from its use. No other circuits, patents, or licenses are implied. This product is intended for use in normal commercial and industrial applications. Any other applications such as those requiring high reliability or other extraordinary environmental requirements are not recommended without additional processing by IDT. IDT reserves the right to change any circuitry or specifications without notice. IDT does not authorize or warrant any IDT product for use in life support devices or critical medical instruments.

ICS843002I-72

FEMTOCLOCKS™ VCXO BASED WCDMA CLOCK GENERATOR/JITTER ATTENUATOR

EEPW 电子产品世界  
.com.cn

Innovate with IDT and accelerate your future networks. Contact:

[www.IDT.com](http://www.IDT.com)

**For Sales**

800-345-7015  
408-284-8200  
Fax: 408-284-2775

**For Tech Support**

[netcom@idt.com](mailto:netcom@idt.com)  
480-763-2056

**Corporate Headquarters**

Integrated Device Technology, Inc.  
6024 Silver Creek Valley Road  
San Jose, CA 95138  
United States  
800 345 7015  
+408 284 8200 (outside U.S.)

**Asia Pacific and Japan**

Integrated Device Technology  
Singapore (1997) Pte. Ltd.  
Reg. No. 199707558G  
435 Orchard Road  
#20-03 Wisma Atria  
Singapore 238877  
+65 6 887 5505

**Europe**

IDT Europe, Limited  
321 Kingston Road  
Leatherhead, Surrey  
KT22 7TU  
England  
+44 (0) 1372 363 339  
Fax: +44 (0) 1372 378851



[www.IDT.com](http://www.IDT.com)