



Integrated  
Circuit  
Systems, Inc.

**PRELIMINARY**

# ICS844004I-04

## FEMTOCLOCKS™ CRYSTAL/LVCMOS-TO-LVDS FREQUENCY SYNTHESIZER

### GENERAL DESCRIPTION



The ICS844004I-04 is a 4 output LVDS Synthesizer optimized to generate clock frequencies for a variety of high performance applications and is a member of the HiPerClocks™ family of high performance clock solutions from ICS. This device can select its input reference clock from either a crystal input or a single-ended clock signal. It can be configured to generate 4 outputs with individually selectable divide-by-one or divide-by-four function via the 4 frequency select pins (F\_SEL[3:0]). The ICS844004I-04 uses ICS' 3<sup>rd</sup> generation low phase noise VCO technology and can achieve 1ps or lower typical rms phase jitter. This ensures that it will easily meet clocking requirements for SDH (STM-1/STM-4/STM-16) and SONET (OC-3/OC12/OC-48). This device is suitable for multi-rate and multiple port line card applications. The ICS844004I-04 is conveniently packaged in a small 24-pin TSSOP package.

### FEATURES

- Four LVDS outputs
- Selectable crystal oscillator interface or LVCMOS/LVTTL single-ended input
- Supports the following applications: SONET/SDH, SATA, or 10Gb Ethernet
- Output frequency range: 140MHz - 170MHz, 560MHz - 680MHz
- VCO range: 560MHz - 680MHz
- Crystal oscillator and CLK range: 17.5MHz - 21.25MHz
- RMS phase jitter @ 622.08MHz output, using a 19.44MHz crystal (12kHz - 20MHz): 0.71ps (typical)
- RMS phase jitter @ 156.25MHz output, using a 19.53125MHz crystal (1.875MHz - 20MHz): 0.51ps (typical)
- RMS phase jitter @ 155.52MHz output, using a 19.44MHz crystal (12kHz - 5MHz): 0.75ps (typical)
- Full 3.3V supply mode
- -40°C to 85°C ambient operating temperature
- Available in both standard and lead-free RoHS compliant packages

### BLOCK DIAGRAM

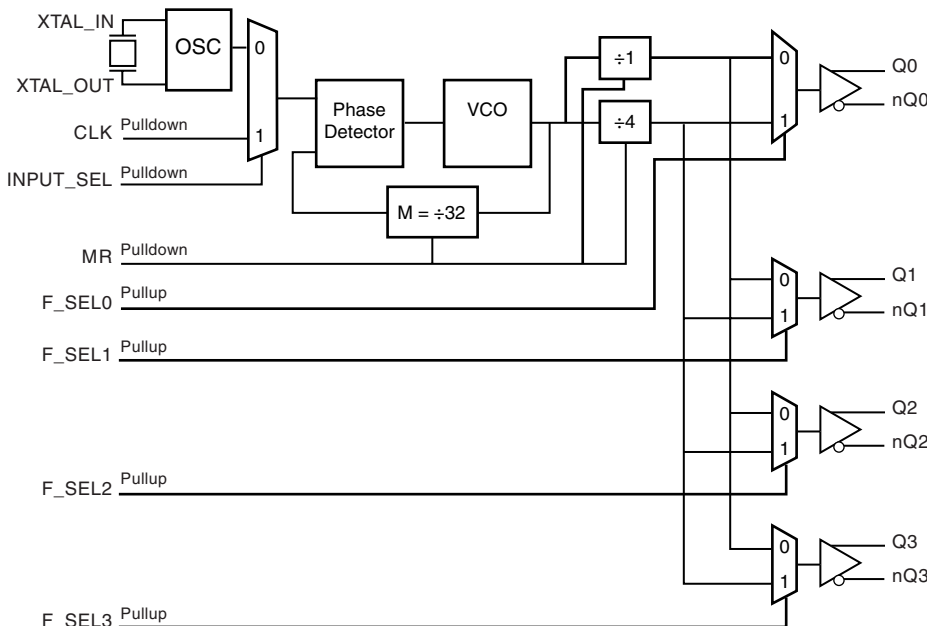

### PIN ASSIGNMENT

nQ1	1	24	nQ2
Q1	2	23	Q2
VDD0	3	22	VDD0
Q0	4	21	Q3
nQ0	5	20	nQ3
MR	6	19	GND
F_SEL3	7	18	F_SEL2
nc	8	17	INPUT_SEL
VDDA	9	16	CLK
F_SEL0	10	15	GND
VDD	11	14	XTAL_IN
F_SEL1	12	13	XTAL_OUT

#### ICS844004I-04

#### 24-Lead TSSOP

4.40mm x 7.8mm x 0.92mm  
package body  
**G Package**  
Top View

The Preliminary Information presented herein represents a product in prototyping or pre-production. The noted characteristics are based on initial product characterization. Integrated Circuit Systems, Incorporated (ICS) reserves the right to change any circuitry or specifications without notice.



Integrated  
Circuit  
Systems, Inc.

**PRELIMINARY**

**ICS844004I-04**  
FEMTOCLOCKS™ CRYSTAL/LVCMOS-TO-  
LVDS FREQUENCY SYNTHESIZER

**TABLE 1. PIN DESCRIPTIONS**

Number	Name	Type		Description
1, 2	nQ1, Q1	Output		Differential output pair. LVDS interface levels.
3, 22	V <sub>DDO</sub>	Power		Output supply pins.
4, 5	Q0, nQ0	Output		Differential output pair. LVDS interface levels.
6	MR	Input	Pulldown	Active HIGH Master Reset. When logic HIGH, the internal dividers are reset causing the true outputs Qx to go low and the inverted outputs nQx to go high. When logic LOW, the internal dividers and the outputs are enabled. LVCMOS/LVTTL interface levels.
7, 10, 12, 18	F_SEL3, F_SEL0, F_SEL1, F_SEL2	Input	Pullup	Frequency select pins. LVCMOS/LVTTL interface levels. See Table 3.
8	nc	Unused		No connect.
9	V <sub>DDA</sub>	Power		Analog supply pin.
11	V <sub>DD</sub>	Power		Core supply pin.
13, 14	XTAL_OUT, XTAL_IN	Input		Parallel resonant crystal interface. XTAL_OUT is the output, XTAL_IN is the input.
15, 19	GND	Power		Power supply ground.
16	CLK	Input	Pulldown	LVCMOS/LVTTL clock input.
17	INPUT_SEL	Input	Pulldown	Selects between crystal or CLK inputs as the the PLL Reference source. Selects XTAL inputs when LOW. Selects CLK when HIGH. LVCMOS/LVTTL interface levels.
20, 21	nQ3, Q3	Output		Differential output pair. LVDS interface levels.
23, 24	Q2, nQ2	Output		Differential output pair. LVDS interface levels.

NOTE: Pulldown and Pullup refer to internal input resistors. See Table 2, Pin Characteristics, for typical values.

**TABLE 2. PIN CHARACTERISTICS**

Symbol	Parameter	Test Conditions	Minimum	Typical	Maximum	Units
C <sub>IN</sub>	Input Capacitance			4		pF
R <sub>PULLDOWN</sub>	Input Pulldown Resistor			51		kΩ
R <sub>PULLUP</sub>	Input Pullup Resistor			51		kΩ

**TABLE 3. OUTPUT CONFIGURATION AND FREQUENCY RANGE FUNCTION TABLE**

Inputs		VCO (MHz)	N Divider Value N0:N3	Output Frequency (MHz) Q0/nQ0:Q3/nQ3	Application
F_SELx	XTAL (MHz)				
0	19.44	622.08	1	622.08	SONET/SDH
1	19.44	622.08	4	155.52	
0	18.75	600	1	600	SATA
1	18.75	600	4	150	
0	19.53125	625	1	625	10 Gigabit Ethernet
1	19.53125	625	4	156.25	
0	20.141601	644.5312	1	644.5312	10 Gigabit Ethernet 66B/64B FEC
1	20.141601	644.5312	4	161.13	



Integrated  
Circuit  
Systems, Inc.

**PRELIMINARY**

**ICS844004I-04**  
FEMTOCLOCKS™ CRYSTAL/LVCMOS-TO-  
LVDS FREQUENCY SYNTHESIZER

**ABSOLUTE MAXIMUM RATINGS**

Supply Voltage, $V_{CC}$	4.6V
Inputs, $V_I$	-0.5V to $V_{CC} + 0.5V$
Outputs, $I_O$	
Continuous Current	10mA
Surge Current	15mA
Package Thermal Impedance, $\theta_{JA}$	70°C/W (0 mps)
Storage Temperature, $T_{STG}$	-65°C to 150°C

NOTE: Stresses beyond those listed under Absolute Maximum Ratings may cause permanent damage to the device. These ratings are stress specifications only. Functional operation of product at these conditions or any conditions beyond those listed in the *DC Characteristics* or *AC Characteristics* is not implied. Exposure to absolute maximum rating conditions for extended periods may affect product reliability.

**TABLE 4A. POWER SUPPLY DC CHARACTERISTICS,  $V_{DD} = V_{DDA} = V_{DDO} = 3.3V \pm 5\%$ ,  $T_A = -40^\circ C$  TO  $85^\circ C$**

Symbol	Parameter	Test Conditions	Minimum	Typical	Maximum	Units
$V_{DD}$	Core Supply Voltage		3.135	3.3	3.465	V
$V_{DDA}$	Analog Supply Voltage		3.135	3.3	3.465	V
$V_{DDO}$	Output Supply Voltage		3.135	3.3	3.465	V
$I_{DD}$	Power Supply Current			80		mA
$I_{DDA}$	Analog Supply Current			8		mA
$I_{DDO}$	Output Supply Current			87		mA

**TABLE 4B. LVCMOS / LVTTTL DC CHARACTERISTICS,  $V_{DD} = V_{DDA} = V_{DDO} = 3.3V \pm 5\%$ ,  $T_A = -40^\circ C$  TO  $85^\circ C$**

Symbol	Parameter	Test Conditions	Minimum	Typical	Maximum	Units
$V_{IH}$	Input High Voltage		2		$V_{DD} + 0.3$	V
$V_{IL}$	Input Low Voltage		-0.3		0.8	V
$I_{IH}$	Input High Current	CLK, MR, INPUT_SEL	$V_{DD} = V_{IN} = 3.465$		150	$\mu A$
		F_SEL0:F_SEL3	$V_{DD} = V_{IN} = 3.465$		5	$\mu A$
$I_{IL}$	Input Low Current	CLK, MR, INPUT_SEL	$V_{DD} = 3.465V, V_{IN} = 0V$	-5		$\mu A$
		F_SEL0:F_SEL3	$V_{DD} = 3.465V, V_{IN} = 0V$	-150		$\mu A$
$\Delta V/\Delta T$	Input Edge Rate	CLK	20% - 80%		TBD	V/ns

**TABLE 4C. LVDS DC CHARACTERISTICS,  $V_{DD} = V_{DDA} = V_{DDO} = 3.3V \pm 5\%$ ,  $T_A = -40^\circ C$  TO  $85^\circ C$**

Symbol	Parameter	Test Conditions	Minimum	Typical	Maximum	Units
$V_{OD}$	Differential Output Voltage			350		mV
$\Delta V_{OD}$	$V_{OD}$ Magnitude Change			40		mV
$V_{OS}$	Offset Voltage			1.35		V
$\Delta V_{OS}$	$V_{OS}$ Magnitude Change			50		mV



Integrated  
Circuit  
Systems, Inc.

**PRELIMINARY**

**ICS844004I-04**  
FEMTOCLOCKS™ CRYSTAL/LVCMOS-TO-  
LVDS FREQUENCY SYNTHESIZER

**TABLE 5. CRYSTAL CHARACTERISTICS**

Parameter	Test Conditions	Minimum	Typical	Maximum	Units
Mode of Oscillation		Fundamental			
Frequency		17.5		21.25	MHz
Equivalent Series Resistance (ESR)				50	$\Omega$
Shunt Capacitance				7	pF
Drive Level				1	mW

NOTE: Characterized using an 18pF parallel resonant crystal.

**TABLE 6. AC CHARACTERISTICS,  $V_{DD} = V_{DDA} = V_{DDO} = 3.3V \pm 5\%$ ,  $T_A = -40^\circ C$  TO  $85^\circ C$**

Symbol	Parameter	Test Conditions	Minimum	Typical	Maximum	Units
$f_{OUT}$	Output Frequency	Output Divider = $\div 1$	560		680	MHz
		Output Divider = $\div 4$	140		170	MHz
$t_{sk(o)}$	Output Skew; NOTE 1, 2			TBD		ps
$j_{jit}(\emptyset)$	RMS Phase Jitter (Random); NOTE 3	155.52MHz, Integration Range: 12kHz - 20MHz		0.75		ps
		156.25MHz, Integration Range: 1.875MHz - 20MHz		0.51		ps
		622.08MHz, Integration Range: 12kHz - 20MHz		0.71		ps
$t_R / t_F$	Output Rise/Fall Time	20% to 80%		290		ps
odc	Output Duty Cycle			50		%

NOTE 1: Defined as skew between outputs at the same supply voltages and with equal load conditions.  
Measured at  $V_{DDO}/2$ .

NOTE 2: This parameter is defined in accordance with JEDEC Standard 65.

NOTE 3: Please refer to the Phase Noise Plot.



Integrated  
Circuit  
Systems, Inc.

**PRELIMINARY**

**ICS844004I-04**  
FEMTOCLOCKS™ CRYSTAL/LVCMOS-TO-  
LVDS FREQUENCY SYNTHESIZER

**TYPICAL PHASE NOISE AT 155.52MHz AT 3.3V**

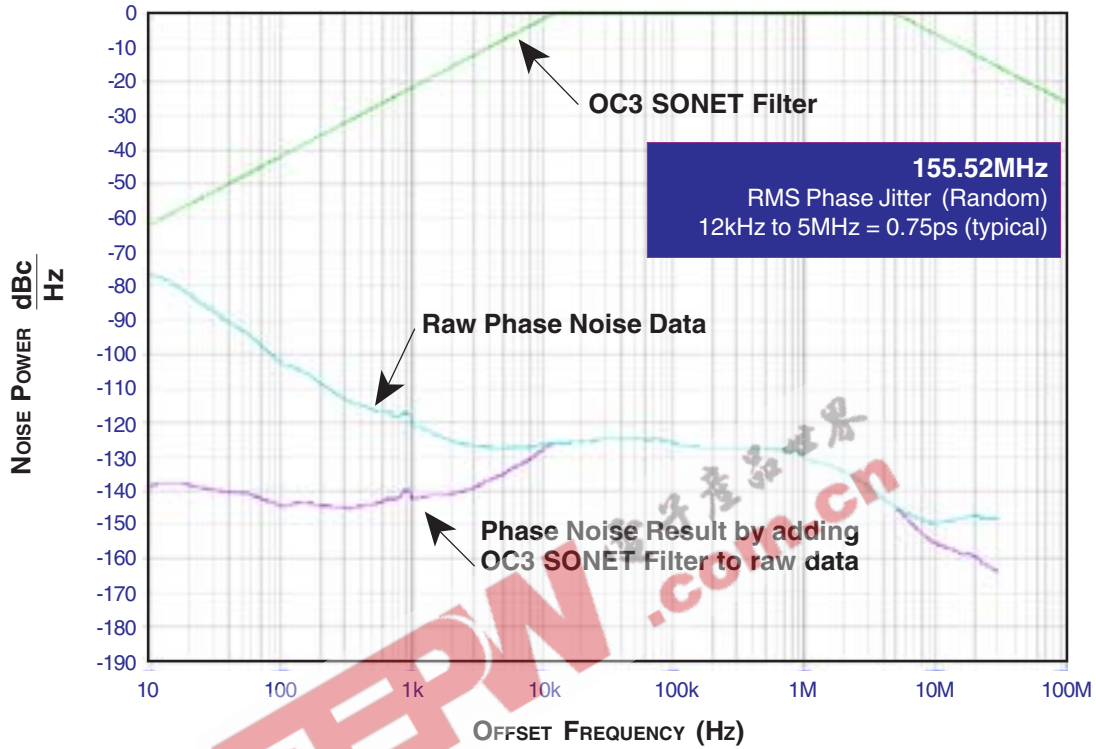

**TYPICAL PHASE NOISE AT 622.08MHz AT 3.3V**

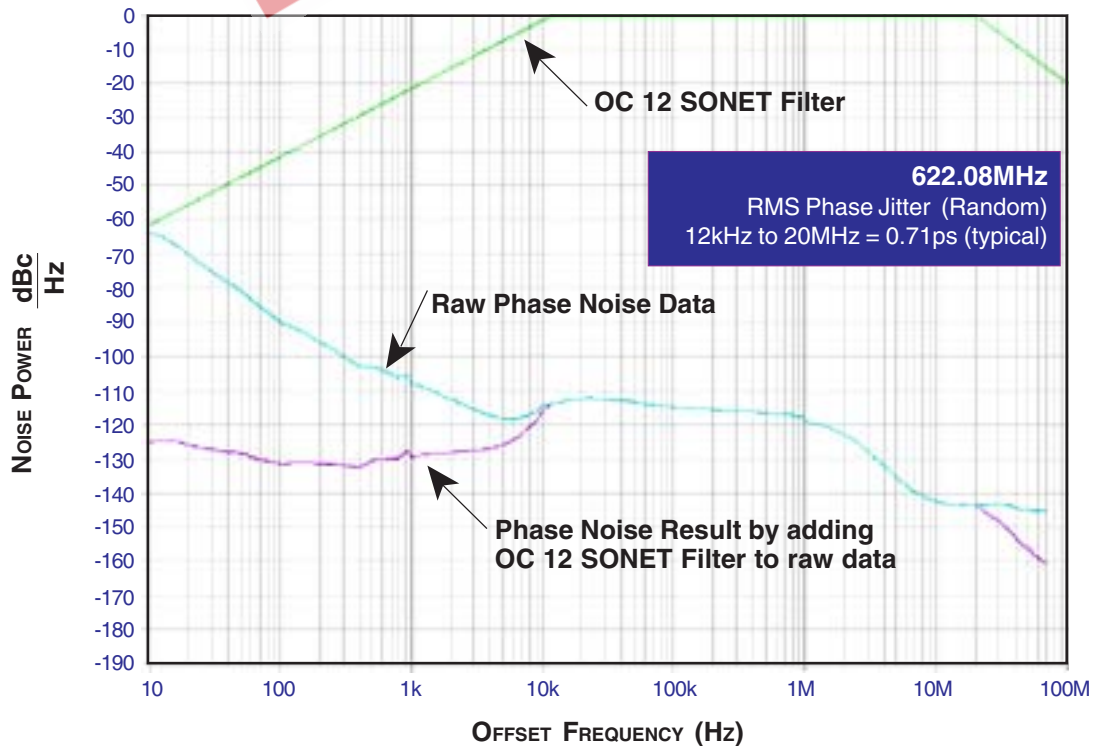



Integrated  
Circuit  
Systems, Inc.

**PRELIMINARY**

**ICS844004I-04**  
FEMTOCLOCKS™ CRYSTAL/LVCMOS-TO-  
LVDS FREQUENCY SYNTHESIZER

**PARAMETER MEASUREMENT INFORMATION**

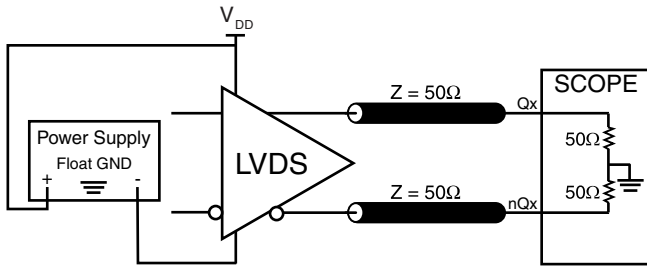

**3.3V CORE/3.3V OUTPUT LOAD AC TEST CIRCUIT**

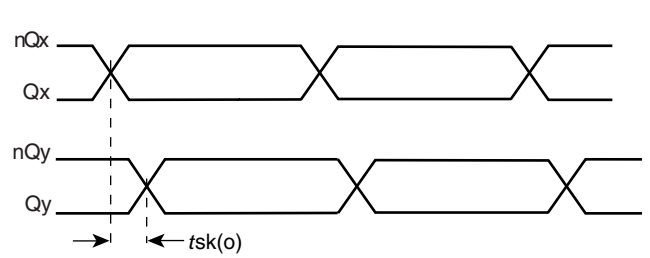

**OUTPUT SKEW**

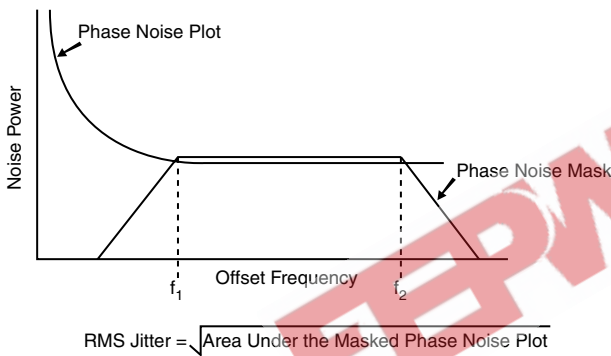

**RMS PHASE JITTER**

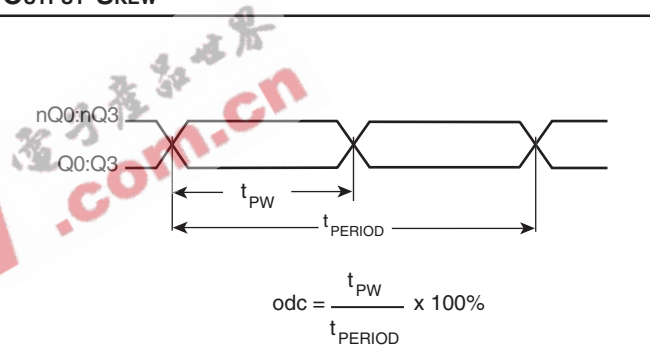

**OUTPUT DUTY CYCLE/PULSE WIDTH/PERIOD**

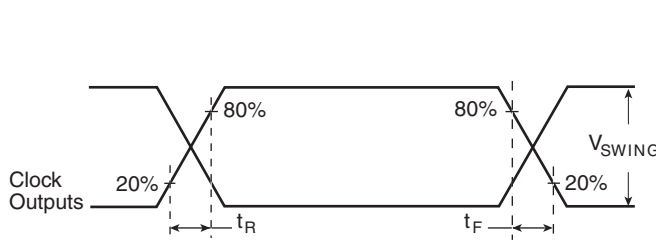

**OUTPUT RISE/FALL TIME**

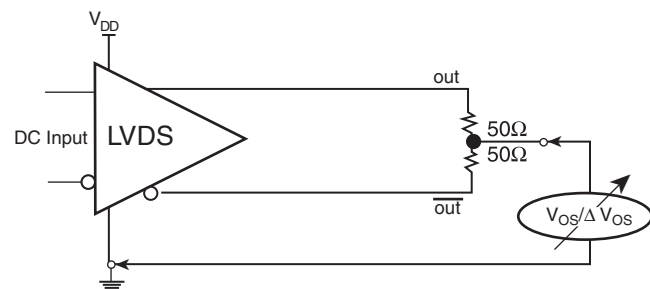

**OFFSET VOLTAGE SETUP**

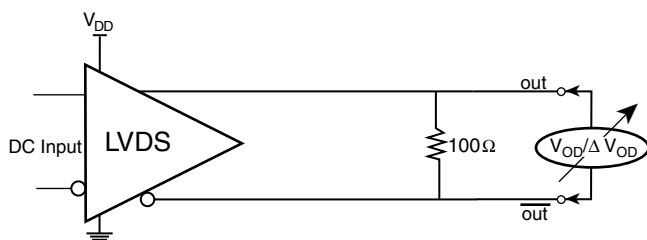

**DIFFERENTIAL OUTPUT VOLTAGE SETUP**



## APPLICATION INFORMATION

### POWER SUPPLY FILTERING TECHNIQUES

As in any high speed analog circuitry, the power supply pins are vulnerable to random noise. The ICS844004I-04 provides separate power supplies to isolate any high switching noise from the outputs to the internal PLL.  $V_{DD}$ ,  $V_{DDA}$ , and  $V_{DDO}$  should be individually connected to the power supply plane through vias, and bypass capacitors should be used for each pin. To achieve optimum jitter performance, power supply isolation is required. *Figure 1* illustrates how a 10Ω resistor along with a 10μF and a .01μF bypass capacitor should be connected to each  $V_{DDA}$ .

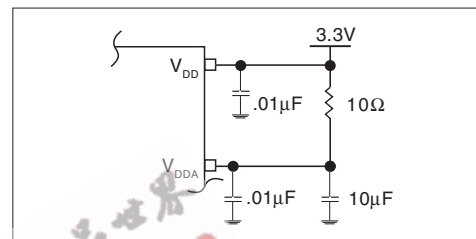

FIGURE 1. POWER SUPPLY FILTERING

### CRYSTAL INPUT INTERFACE

The ICS844004I-04 has been characterized with 18pF parallel resonant crystals. The capacitor values shown in *Figure 2* below were determined using a 19.44MHz 18pF

parallel resonant crystal and were chosen to minimize the ppm error.

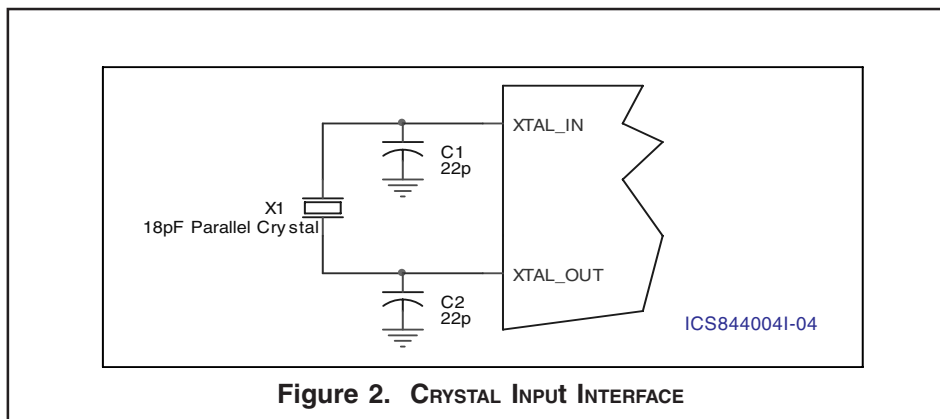

Figure 2. CRYSTAL INPUT INTERFACE





Integrated  
Circuit  
Systems, Inc.

**PRELIMINARY**

**ICS844004I-04**  
FEMTOCLOCKS™ CRYSTAL/LVCMOS-TO-  
LVDS FREQUENCY SYNTHESIZER

**RECOMMENDATIONS FOR UNUSED INPUT AND OUTPUT PINS**

**INPUTS:**

**CRYSTAL INPUT:**

For applications not requiring the use of the crystal oscillator input, both XTAL\_IN and XTAL\_OUT can be left floating. Though not required, but for additional protection, a 1kΩ resistor can be tied from XTAL\_IN to ground.

**CLK INPUT:**

For applications not requiring the use of a clock input, it can be left floating. Though not required, but for additional protection, a 1kΩ resistor can be tied from the CLK input to ground.

**LVCMOS CONTROL PINS:**

All control pins have internal pull-ups or pull-downs; additional resistance is not required but can be added for additional protection. A 1kΩ resistor can be used.

**OUTPUTS:**

**LVDS**

All unused LVDS outputs can be left floating. We recommend that there is no trace attached. Both sides of the differential output pair should either be left floating or terminated.

**3.3V LVDS DRIVER TERMINATION**

A general LVDS interface is shown in *Figure 3*. In a 100Ω differential transmission line environment, LVDS drivers require a matched load termination of 100Ω across near

the receiver input. For a multiple LVDS outputs buffer, if only partial outputs are used, it is recommended to terminate the unused outputs.

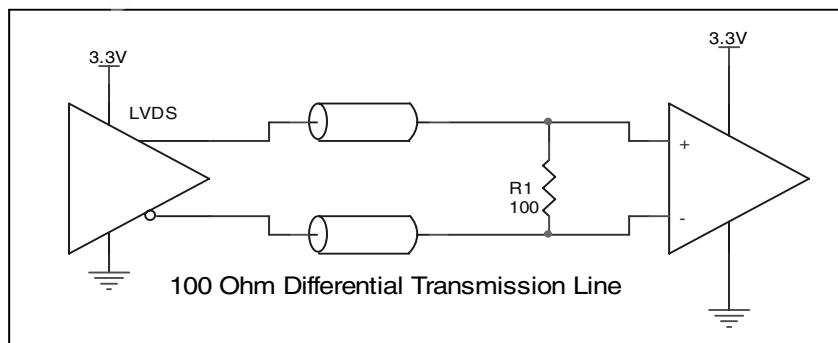

**FIGURE 3. TYPICAL LVDS DRIVER TERMINATION**





Integrated  
Circuit  
Systems, Inc.

**PRELIMINARY**

**ICS844004I-04**  
FEMTOCLOCKS™ CRYSTAL/LVCMOS-TO-  
LVDS FREQUENCY SYNTHESIZER

**SCHEMATIC EXAMPLE**

Figure 4 shows a schematic example for ICS844004i-04. In this example, the input is a 19.44MHz parallel resonant crystal with load capacitor CL=18pF. The 22pF frequency fine tuning capacitors are used C1 and C2. This example also shows general logic control input handling. For decoupling capacitors, it is recommended to have one decouple capacitor per power pin.

Each decoupling capacitor should be located as close as possible to the power pin. The low pass filter R2, C3 and C4 should also be located as close to the VCCA pin as possible. For LVDS driver, the unused output pairs should be terminated with a 100Ω resistor across.

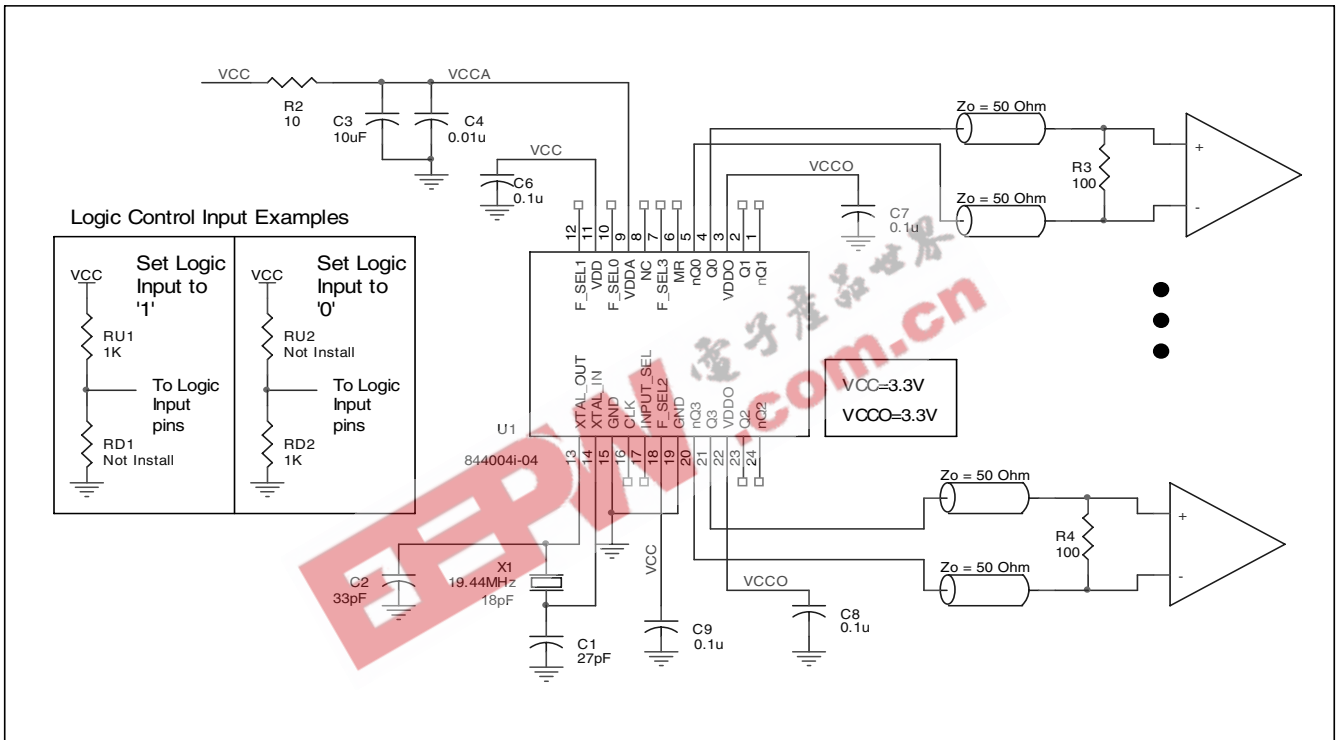

**FIGURE 4. ICS844004I-04 SCHEMATIC EXAMPLE**



## POWER CONSIDERATIONS

This section provides information on power dissipation and junction temperature for the ICS844004I-04. Equations and example calculations are also provided.

### 1. Power Dissipation.

The total power dissipation for the ICS844004I-04 is the sum of the core power plus the power dissipated in the load(s). The following is the power dissipation for  $V_{DD} = 3.3V + 5\% = 3.465V$ , which gives worst case results.

- Power (core)<sub>MAX</sub> =  $V_{DD\_MAX} * (I_{DD\_MAX} + I_{DDA\_MAX}) = 3.465V * (80mA + 8mA) = 304.92mW$
- Power (outputs)<sub>MAX</sub> =  $V_{DDO\_MAX} * I_{DDO\_MAX} = 3.465V * 87mA = 301.45mW$

$$\text{Total Power}_{\_MAX} = 304.92mW + 301.45mW = 606.37mW$$

### 2. Junction Temperature.

Junction temperature,  $T_j$ , is the temperature at the junction of the bond wire and bond pad and directly affects the reliability of the device. The maximum recommended junction temperature for HiPerClockS™ devices is 125°C.

The equation for  $T_j$  is as follows:  $T_j = \theta_{JA} * Pd\_total + T_A$

$T_j$  = Junction Temperature

$\theta_{JA}$  = Junction-to-Ambient Thermal Resistance

$Pd\_total$  = Total Device Power Dissipation (example calculation is in section 1 above)

$T_A$  = Ambient Temperature

In order to calculate junction temperature, the appropriate junction-to-ambient thermal resistance  $\theta_{JA}$  must be used. Assuming a moderate air flow of 1 meter per second and a multi-layer board, the appropriate value is 65°C/W per Table 7 below.

Therefore,  $T_j$  for an ambient temperature of 85°C with all outputs switching is:

$$85^\circ C + 0.606W * 65^\circ C/W = 124^\circ C. \text{ This is below the limit of } 125^\circ C.$$

This calculation is only an example.  $T_j$  will obviously vary depending on the number of loaded outputs, supply voltage, air flow, and the type of board (single layer or multi-layer).

**TABLE 7. THERMAL RESISTANCE  $\theta_{JA}$  FOR 24-LEAD TSSOP, FORCED CONVECTION**

$\theta_{JA}$ by Velocity (Meters per Second)			
	0	1	2.5
Multi-Layer PCB, JEDEC Standard Test Boards	70°C/W	65°C/W	62°C/W



Integrated  
Circuit  
Systems, Inc.

**PRELIMINARY**

**ICS844004I-04**  
FEMTOCLOCKS™ CRYSTAL/LVCMOS-TO-  
LVDS FREQUENCY SYNTHESIZER

## RELIABILITY INFORMATION

TABLE 8.  $\theta_{JA}$  VS. AIR FLOW TABLE FOR 24 LEAD TSSOP

$\theta_{JA}$ by Velocity (Meters per Second)			
	0	1	2.5
Multi-Layer PCB, JEDEC Standard Test Boards	70°C/W	65°C/W	62°C/W

### TRANSISTOR COUNT

The transistor count for ICS844004I-04 is: 2285

EEPW.com.cn 电子产品世界



Integrated  
Circuit  
Systems, Inc.

**PRELIMINARY**

**ICS844004I-04**  
FEMTOCLOCKS™ CRYSTAL/LVCMOS-TO-  
LVDS FREQUENCY SYNTHESIZER

PACKAGE OUTLINE - G SUFFIX FOR 24 LEAD TSSOP

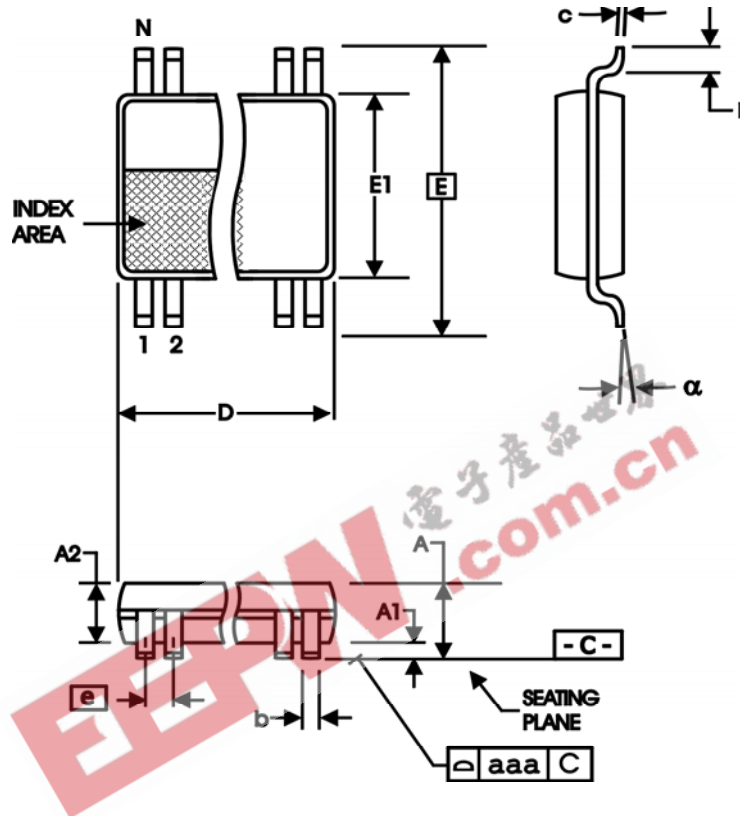

TABLE 9. PACKAGE DIMENSIONS

SYMBOL	Millimeters	
	Minimum	Maximum
N	24	
A	--	1.20
A1	0.05	0.15
A2	0.80	1.05
b	0.19	0.30
c	0.09	0.20
D	7.70	7.90
E	6.40 BASIC	
E1	4.30	4.50
e	0.65 BASIC	
L	0.45	0.75
alpha	0°	8°
aaa	--	0.10

Reference Document: JEDEC Publication 95, MO-153



Integrated  
Circuit  
Systems, Inc.

**PRELIMINARY**

**ICS844004I-04**  
FEMTOCLOCKS™ CRYSTAL/LVCMOS-TO-  
LVDS FREQUENCY SYNTHESIZER

**TABLE 10. ORDERING INFORMATION**

Part/Order Number	Marking	Package	Shipping Packaging	Temperature
ICS844004AGI-04	ICS844004AI04	24 Lead TSSOP	tube	-40°C to 85°C
ICS844004AGI-04T	ICS844004AI04	24 Lead TSSOP	2500 tape & reel	-40°C to 85°C
ICS844004AGI-04LF	ICS44004AI04L	24 Lead "Lead-Free" TSSOP	tube	-40°C to 85°C
ICS844004AGI-04LFT	ICS44004AI04L	24 Lead "Lead-Free" TSSOP	2500 tape & reel	-40°C to 85°C

NOTE: Parts that are ordered with an "LF" suffix to the part number are the Pb-Free configuration and are RoHS compliant.

EEPW 电子产品世界  
.com.cn

The aforementioned trademarks, HiPerClockS and FEMTOCLOCKS are trademarks of Integrated Circuit Systems, Inc. or its subsidiaries in the United States and/or other countries. While the information presented herein has been checked for both accuracy and reliability, Integrated Circuit Systems, Incorporated (ICS) assumes no responsibility for either its use or for infringement of any patents or other rights of third parties, which would result from its use. No other circuits, patents, or licenses are implied. This product is intended for use in normal commercial and industrial applications. Any other applications such as those requiring high reliability or other extraordinary environmental requirements are not recommended without additional processing by ICS. ICS reserves the right to change any circuitry or specifications without notice. ICS does not authorize or warrant any ICS product for use in life support devices or critical medical instruments.