



Integrated
Circuit
Systems, Inc.

PRELIMINARY

ICS844246

FEMTOCLOCKS™ CRYSTAL-TO-LVDS

FREQUENCY SYNTHESIZER W/INTEGRATED FANOUT BUFFER

GENERAL DESCRIPTION



The ICS844246 is a Crystal-to-LVDS Clock Synthesizer/Fanout Buffer designed for Fibre Channel and Gigabit Ethernet applications and is a member of the HiPerClockS™ family of High Performance Clock Solutions from ICS.

The output frequency can be set using the frequency select pins and a 25MHz crystal for Ethernet frequencies, or a 26.5625MHz crystal for a Fibre Channel. The low phase noise characteristics of the ICS844246 make it an ideal clock for these demanding applications.

FEATURES

- Six LVDS outputs
- Crystal oscillator interface
- Output frequency range: 53.125MHz to 333.3333MHz
- Crystal input frequency range: 25MHz to 33.333MHz
- RMS phase jitter at 125MHz, using a 25MHz crystal (1.875MHz to 20MHz): 0.39ps (typical)
- Full 3.3V or 3.3V core, 2.5V output supply mode
- 0°C to 70°C ambient operating temperature
- Industrial temperature information available upon request
- Available in both standard and lead-free RoHS-compliant packages

SELECT FUNCTION TABLE

Inputs			Function		
FB_SEL	N_SEL1	N_SEL0	M Divide	N Divide	M/N
0	0	0	20	2	10
0	0	1	20	4	5
0	1	0	20	5	4
0	1	1	20	8	2.5
1	0	0	24	3	8
1	0	1	24	4	6
1	1	0	24	6	4
1	1	1	24	12	2

BLOCK DIAGRAM

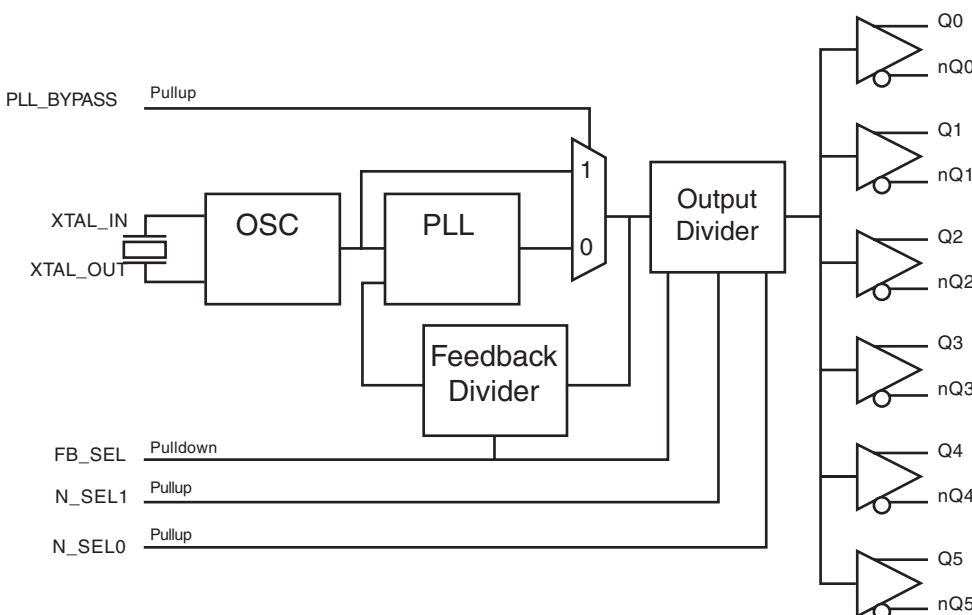

PIN ASSIGNMENT

V _{DD0}	1	24	Q3
V _{DD0}	2	23	nQ3
nQ2	3	22	Q4
Q2	4	21	nQ4
nQ1	5	20	Q5
Q1	6	19	nQ5
nQ0	7	18	N_SEL1
Q0	8	17	GND
PLL_BYPASS	9	16	GND
V _{DDA}	10	15	N_SEL0
V _{DD}	11	14	XTAL_OUT
FB_SEL	12	13	XTAL_IN

ICS843246

24-Lead, 300-MIL SOIC
7.5mm x 15.33mm x 2.3mm
body package
M Package
Top View

24-Lead TSSOP
4.40mm x 7.8mm x 0.92mm
body package
G Package
Top View

The Preliminary Information presented herein represents a product in prototyping or pre-production. The noted characteristics are based on initial product characterization. Integrated Circuit Systems, Incorporated (ICS) reserves the right to change any circuitry or specifications without notice.



Integrated
Circuit
Systems, Inc.

PRELIMINARY

ICS844246

FEMTOCLOCKS™ CRYSTAL-TO-LVDS

FREQUENCY SYNTHESIZER W/INTEGRATED FANOUT BUFFER

TABLE 1. PIN DESCRIPTIONS

Number	Name	Type		Description
1, 2	V _{DDO}	Power		Output supply pins.
3, 4	nQ2, Q2	Output		Differential output pair. LVDS interface levels.
5, 6	nQ1, Q1	Output		Differential output pair. LVDS interface levels.
7, 8	nQ0, Q0	Output		Differential output pair. LVDS interface levels.
9	PLL_BYPASS	Input	Pullup	Selects between the PLL and crystal inputs as the input to the dividers. When LOW, selects PLL. When HIGH, selects XTAL_IN, XTAL_OUT. LVCMOS / LVTTTL interface levels.
10	V _{DDA}	Power		Analog supply pin.
11	V _{DD}	Power		Core supply pin.
12	FB_SEL	Input	Pulldown	Feedback frequency select pin. LVCMOS/LVTTTL interface levels.
13, 14	XTAL_IN, XTAL_OUT	Input		Crystal oscillator interface. XTAL_IN is the input. XTAL_OUT is the output.
15, 18	N_SEL0 N_SEL1	Input	Pullup	Output frequency select pin. LVCMOS/LVTTTL interface levels.
16, 17	GND			Power supply ground.
19, 20	nQ5, Q5	Output		Differential output pair. LVDS interface levels.
21, 22	nQ4, Q4	Output		Differential output pair. LVDS interface levels.
23, 24	nQ3, Q3	Output		Differential output pair. LVDS interface levels.

NOTE: *Pullup* and *Pulldown* refer to internal input resistors. See Table 2, Pin Characteristics, for typical values.

TABLE 2. PIN CHARACTERISTICS

Symbol	Parameter	Test Conditions	Minimum	Typical	Maximum	Units
C _{IN}	Input Capacitance			4		pF
R _{PULLUP}	Input Pullup Resistor			51		kΩ
R _{PULLDOWN}	Input Pulldown Resistor			51		kΩ



Integrated
Circuit
Systems, Inc.

PRELIMINARY

ICS844246

FEMTOCLOCKS™ CRYSTAL-TO-LVDS

FREQUENCY SYNTHESIZER W/INTEGRATED FANOUT BUFFER

CRYSTAL FUNCTION TABLE

Inputs				Function			
XTAL (MHz)	FB_SEL	N_SEL1	N_SELO	M	VCO (MHz)	N	Output (MHz)
25	0	0	0	20	500	2	250
25	0	0	1	20	500	4	125
25	0	1	0	20	500	5	100
25	0	1	1	20	500	8	62.5
25	1	0	0	24	600	3	200
25	1	0	1	24	600	4	150
25	1	1	0	24	600	6	100
25	1	1	1	24	600	12	50
26.5625	0	1	0	20	531.25	5	106.25
26.5625	1	0	0	24	637.5	3	212.5
26.5625	1	0	1	24	637.5	4	159.375
26.5625	1	1	0	24	637.5	6	106.25
26.5625	1	1	1	24	637.5	12	53.125
30	0	0	0	20	600	2	300
30	0	0	1	20	600	4	150
30	0	1	0	20	600	5	120
30	0	1	1	20	600	8	75
31.25	0	0	0	20	625	2	312.5
31.25	0	0	1	20	625	4	156.25
31.25	0	1	0	20	625	5	125
31.25	0	1	1	20	625	8	78.125
33.3333	0	0	0	20	666.6667	2	333.3333
33.3333	0	0	1	20	666.6667	4	166.6667
33.3333	0	1	0	20	666.6667	5	133.3333
33.3333	0	1	1	20	666.6667	8	83.3333



Integrated
Circuit
Systems, Inc.

PRELIMINARY

ICS844246

FEMTOCLOCKS™ CRYSTAL-TO-LVDS

FREQUENCY SYNTHESIZER W/INTEGRATED FANOUT BUFFER

ABSOLUTE MAXIMUM RATINGS

Supply Voltage, V_{DD}	4.6V
Inputs, V_I	-0.5V to $V_{DD} + 0.5V$
Outputs, I_O	
Continuous Current	10mA
Surge Current	15mA
Package Thermal Impedance, θ_{JA}	
24 Lead SOIC	50°C/W (0 lfpm)
24 Lead TSSOP	70°C/W (0 mps)
Storage Temperature, T_{STG}	-65°C to 150°C

NOTE: Stresses beyond those listed under Absolute Maximum Ratings may cause permanent damage to the device. These ratings are stress specifications only. Functional operation of product at these conditions or any conditions beyond those listed in the *DC Characteristics* or *AC Characteristics* is not implied. Exposure to absolute maximum rating conditions for extended periods may affect product reliability.

TABLE 4A. POWER SUPPLY DC CHARACTERISTICS, $V_{DD} = V_{DDA} = V_{DDO} = 3.3V \pm 5\%$, $T_A = 0^\circ C$ TO $70^\circ C$

Symbol	Parameter	Test Conditions	Minimum	Typical	Maximum	Units
V_{DD}	Core Supply Voltage		3.135	3.3	3.465	V
V_{DDA}	Analog Supply Voltage		3.135	3.3	3.465	V
V_{DDO}	Output Supply Voltage		3.135	3.3	3.465	V
I_{DD}	Power Supply Current			125		mA
I_{DDA}	Analog Supply Current			7		mA
I_{DDO}	Output Supply Current			127		mA

TABLE 4B. POWER SUPPLY DC CHARACTERISTICS, $V_{DD} = V_{DDA} = 3.3V \pm 5\%$, $V_{DDO} = 2.5V \pm 5\%$, $T_A = 0^\circ C$ TO $70^\circ C$

Symbol	Parameter	Test Conditions	Minimum	Typical	Maximum	Units
V_{DD}	Core Supply Voltage		3.135	3.3	3.465	V
V_{DDA}	Analog Supply Voltage		3.135	3.3	3.465	V
V_{DDO}	Output Supply Voltage		2.375	2.5	2.625	V
I_{DD}	Power Supply Current			125		mA
I_{DDA}	Analog Supply Current			7		mA
I_{DDO}	Output Supply Current			115		mA

TABLE 4C. LVCMOS / LVTTTL DC CHARACTERISTICS, $V_{DD} = V_{DDA} = 3.3V \pm 5\%$, $V_{DDO} = 3.3V \pm 5\%$ OR $2.5V \pm 5\%$, $T_A = 0^\circ C$ TO $70^\circ C$

Symbol	Parameter	Test Conditions	Minimum	Typical	Maximum	Units
V_{IH}	Input High Voltage		2		$V_{DD} + 0.3$	V
V_{IL}	Input Low Voltage		-0.3		0.8	V
I_{IH}	Input High Current	FB_SEL	$V_{DD} = V_{IN} = 3.465V$		150	μA
		PLL_BYPASS, N_SEL0, N_SEL1	$V_{DD} = V_{IN} = 3.465V$		5	μA
I_{IL}	Input Low Current	FB_SEL	$V_{DD} = 3.465V, V_{IN} = 0V$	-5		μA
		PLL_BYPASS, N_SEL0, N_SEL1	$V_{DD} = 3.465V, V_{IN} = 0V$	-150		μA



Integrated
Circuit
Systems, Inc.

PRELIMINARY

ICS844246

FEMTOCLOCKS™ CRYSTAL-TO-LVDS

FREQUENCY SYNTHESIZER W/INTEGRATED FANOUT BUFFER

TABLE 4D. LVDS DC CHARACTERISTICS, $V_{DD} = V_{DDA} = V_{DDO} = 3.3V \pm 5\%$ $T_A = 0^\circ C$ TO $70^\circ C$

Symbol	Parameter	Test Conditions	Minimum	Typical	Maximum	Units
V_{OD}	Differential Output Voltage			387		mV
ΔV_{OD}	V_{OD} Magnitude Change			40		mV
V_{OS}	Offset Voltage			1.29		V
ΔV_{OS}	V_{OS} Magnitude Change			50		mV

NOTE: Please refer to Parameter Measurement Information for output information.

TABLE 4E. LVDS DC CHARACTERISTICS, $V_{DD} = V_{DDA} = 3.3V \pm 5\%$, $V_{DDO} = 2.5V \pm 5\%$, $T_A = 0^\circ C$ TO $70^\circ C$

Symbol	Parameter	Test Conditions	Minimum	Typical	Maximum	Units
V_{OD}	Differential Output Voltage			379		mV
ΔV_{OD}	V_{OD} Magnitude Change			40		mV
V_{OS}	Offset Voltage			1.24		V
ΔV_{OS}	V_{OS} Magnitude Change			50		mV

TABLE 5. CRYSTAL CHARACTERISTICS

Parameter	Test Conditions	Minimum	Typical	Maximum	Units
Mode of Oscillation		Fundamental			
Frequency		25		33.333	MHz
Equivalent Series Resistance (ESR)				50	Ω
Shunt Capacitance				7	pF
Drive Level				1	mW

NOTE: Characterized using an 18pf parallel resonant crystal.



Integrated
Circuit
Systems, Inc.

PRELIMINARY

ICS844246

FEMTOCLOCKS™ CRYSTAL-TO-LVDS

FREQUENCY SYNTHESIZER W/INTEGRATED FANOUT BUFFER

TABLE 6A. AC CHARACTERISTICS, $V_{DD} = V_{DDA} = V_{DDO} = 3.3V \pm 5\%$, $T_A = 0^\circ C$ TO $70^\circ C$

Symbol	Parameter	Test Conditions	Minimum	Typical	Maximum	Units
F_{OUT}	Output Frequency		53.125		333.33	MHz
$f_{jit}(\emptyset)$	RMS Phase Jitter (Random)	125MHz, Integration Range: 1.875MHz - 20MHz		0.39		ps
$t_{sk}(o)$	Output Skew; NOTE 1, 2			TBD		ps
t_R / t_F	Output Rise/Fall Time	20% to 80%		355		ps
odc	Output Duty Cycle			50		%
t_{LOCK}	PLL Lock Time				1	ms

See Parameter Measurement Information section.

NOTE 1: Defined as skew between outputs at the same supply voltage and with equal load conditions. Measured at the output differential crossing points.

NOTE 2: This parameter is defined in accordance with JEDEC Standard 65.

TABLE 6B. AC CHARACTERISTICS, $V_{DD} = V_{DDA} = 3.3V \pm 5\%$, $V_{DDO} = 2.5V \pm 5\%$, $T_A = 0^\circ C$ TO $70^\circ C$

Symbol	Parameter	Test Conditions	Minimum	Typical	Maximum	Units
F_{OUT}	Output Frequency		53.125		333.33	MHz
$f_{jit}(\emptyset)$	RMS Phase Jitter (Random)	125MHz, Integration Range: 1.875MHz - 20MHz		0.38		ps
$t_{sk}(o)$	Output Skew; NOTE 1, 2			TBD		ps
t_R / t_F	Output Rise/Fall Time	20% to 80%		380		ps
odc	Output Duty Cycle			50		%
t_{LOCK}	PLL Lock Time				1	ms

See Parameter Measurement Information section.

NOTE 1: Defined as skew between outputs at the same supply voltage and with equal load conditions. Measured at the output differential crossing points.

NOTE 2: This parameter is defined in accordance with JEDEC Standard 65.



Integrated
Circuit
Systems, Inc.

PRELIMINARY

ICS844246

FEMTOCLOCKS™ CRYSTAL-TO-LVDS
FREQUENCY SYNTHESIZER W/INTEGRATED FANOUT BUFFER

TYPICAL PHASE NOISE AT 125MHz @ 3.3V

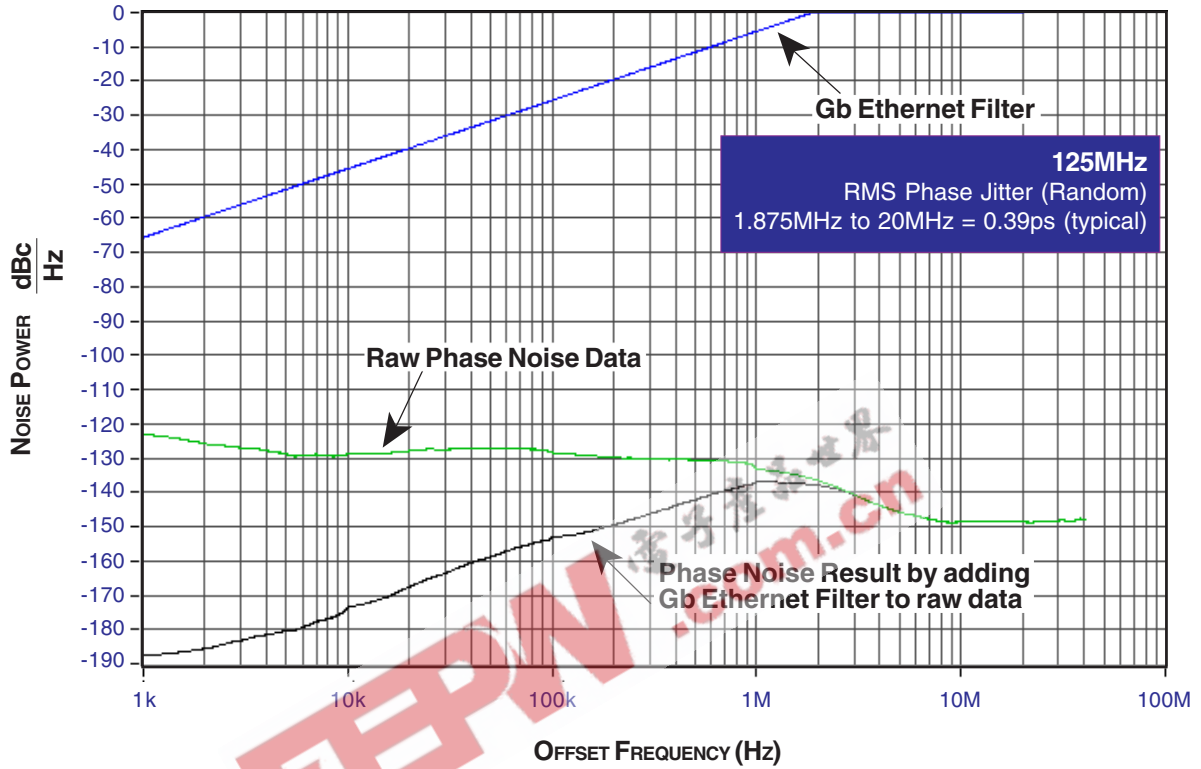



Integrated
Circuit
Systems, Inc.

PRELIMINARY

ICS844246

FEMTOCLOCKS™ CRYSTAL-TO-LVDS

FREQUENCY SYNTHESIZER W/INTEGRATED FANOUT BUFFER

PARAMETER MEASUREMENT INFORMATION

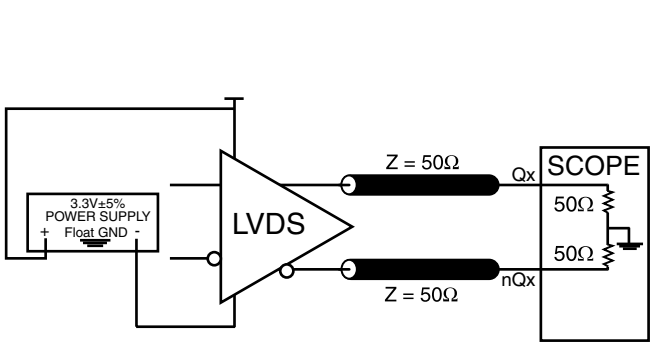

3.3V OUTPUT LOAD AC TEST CIRCUIT

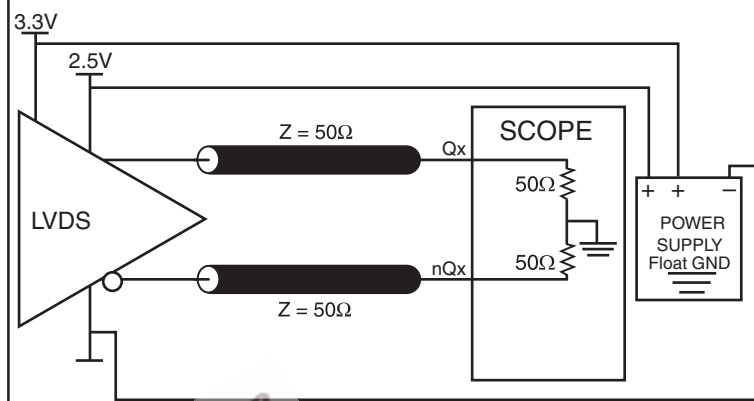

3.3V/2.5V OUTPUT LOAD AC TEST CIRCUIT

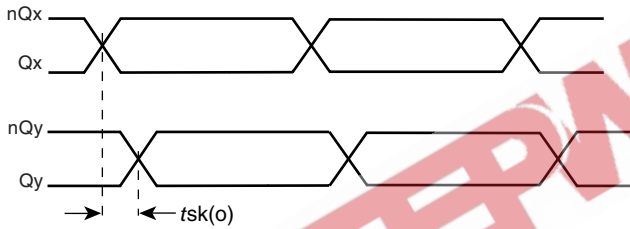

OUTPUT SKEW

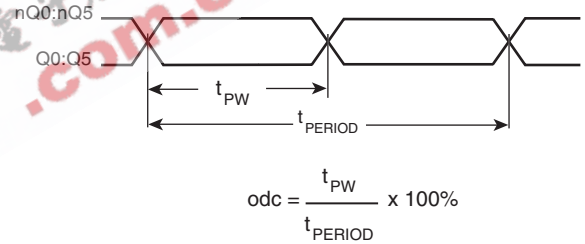

OUTPUT DUTY CYCLE/PULSE WIDTH/PERIOD

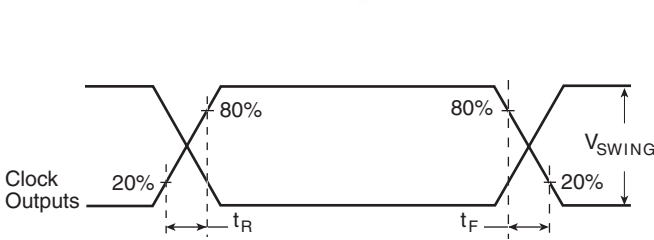

OUTPUT RISE/FALL TIME

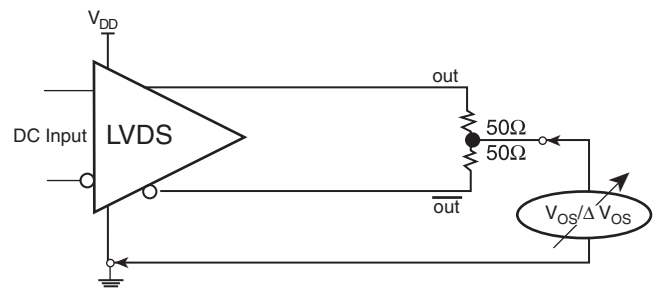

OFFSET VOLTAGE SETUP

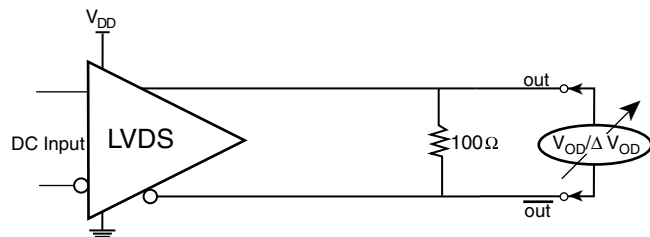

DIFFERENTIAL OUTPUT VOLTAGE SETUP



APPLICATION INFORMATION

POWER SUPPLY FILTERING TECHNIQUES

As in any high speed analog circuitry, the power supply pins are vulnerable to random noise. The ICS844246 provides separate power supplies to isolate any high switching noise from the outputs to the internal PLL. V_{DD} , V_{DDA} and V_{DDO} should be individually connected to the power supply plane through vias, and bypass capacitors should be used for each pin. To achieve optimum jitter performance, power supply isolation is required. *Figure 1* illustrates how a 10Ω resistor along with a $10\mu\text{F}$ and a $.01\mu\text{F}$ bypass capacitor should be connected to each V_{DDA} pin. The 10Ω resistor can also be replaced by a ferrite bead.

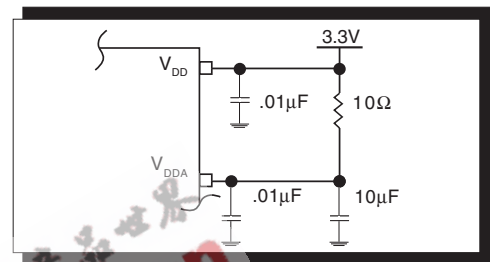

FIGURE 1. POWER SUPPLY FILTERING

CRYSTAL INPUT INTERFACE

The ICS844246 has been characterized with 18pF parallel resonant crystals. The capacitor values shown in *Figure 2*

below were determined using an 18pF parallel resonant crystal and were chosen to minimize the ppm error.

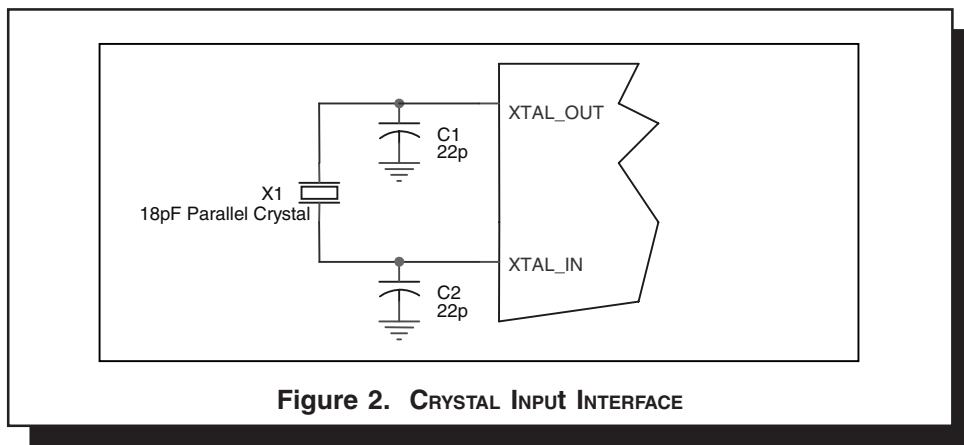

Figure 2. CRYSTAL INPUT INTERFACE



Integrated
Circuit
Systems, Inc.

PRELIMINARY

ICS844246

FEMTOCLOCKS™ CRYSTAL-TO-LVDS
FREQUENCY SYNTHESIZER W/INTEGRATED FANOUT BUFFER

RECOMMENDATIONS FOR UNUSED INPUT AND OUTPUT PINS

INPUTS:

LVC MOS CONTROL PINS:

All control pins have internal pull-ups or pull-downs; additional resistance is not required but can be added for additional protection. A 1kΩ resistor can be used.

OUTPUTS:

LVDS

All unused LVDS output pairs can be either left floating or terminated with 100Ω across. If they are left floating, we recommend that there is no trace attached.

3.3V, 2.5V LVDS DRIVER TERMINATION

A general LVDS interface is shown in *Figure 3*. In a 100Ω differential transmission line environment, LVDS drivers

require a matched load termination of 100Ω across near the receiver input.

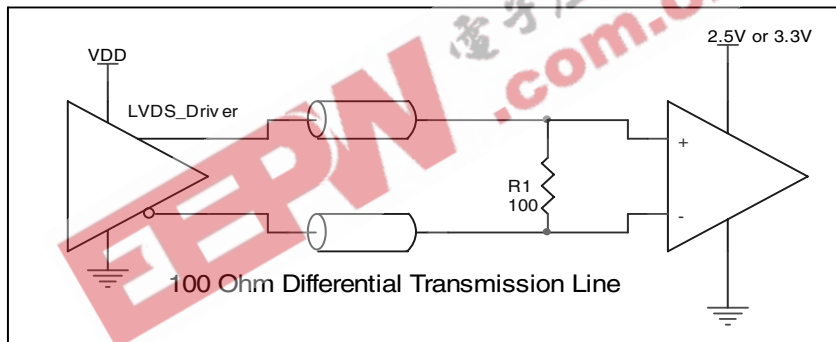

FIGURE 3. TYPICAL LVDS DRIVER TERMINATION



Integrated
Circuit
Systems, Inc.

PRELIMINARY

ICS844246

FEMTOCLOCKS™ CRYSTAL-TO-LVDS
FREQUENCY SYNTHESIZER W/INTEGRATED FANOUT BUFFER

RELIABILITY INFORMATION

TABLE 7A. θ_{JA} VS. AIR FLOW TABLE FOR 24 LEAD SOIC

θ_{JA} by Velocity (Linear Feet per Minute)			
	0	200	500
Multi-Layer PCB, JEDEC Standard Test Boards	50°C/W	43°C/W	38°C/W

NOTE: Most modern PCB designs use multi-layered boards. The data in the second row pertains to most designs.

TABLE 7B. θ_{JA} VS. AIR FLOW TABLE FOR 24 LEAD TSSOP

θ_{JA} by Velocity (Meters per Second)			
	0	1	2.5
Multi-Layer PCB, JEDEC Standard Test Boards	70°C/W	65°C/W	62°C/W

TRANSISTOR COUNT

The transistor count for ICS844246 is: 3887



Integrated
Circuit
Systems, Inc.

PRELIMINARY

ICS844246

FEMTOCLOCKS™ CRYSTAL-TO-LVDS
FREQUENCY SYNTHESIZER W/INTEGRATED FANOUT BUFFER

PACKAGE OUTLINE - M SUFFIX FOR 24 LEAD SOIC

PACKAGE OUTLINE - G SUFFIX FOR 24 LEAD TSSOP

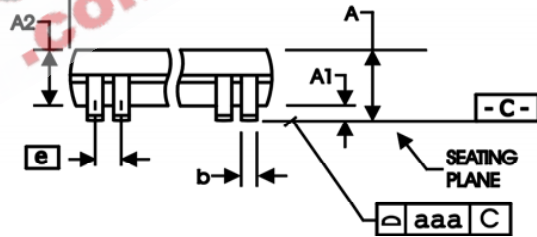
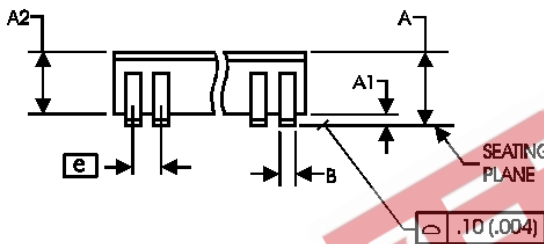
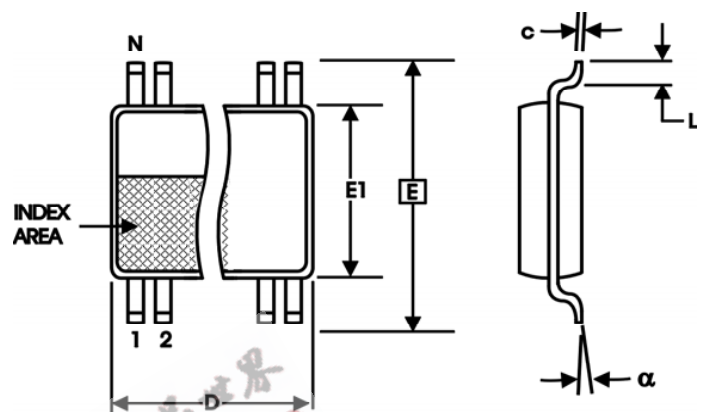
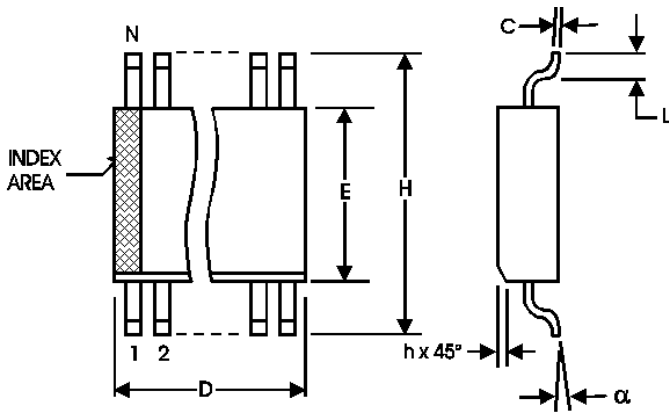

TABLE 8A. PACKAGE DIMENSIONS

SYMBOL	Millimeters	
	Minimum	Maximum
N	24	
A	--	2.65
A1	0.10	--
A2	2.05	2.55
B	0.33	0.51
C	0.18	0.32
D	15.20	15.85
E	7.40	7.60
e	1.27 BASIC	
H	10.00	10.65
h	0.25	0.75
L	0.40	1.27
α	0°	8°

Reference Document: JEDEC Publication 95, MS-013, MO-119

TABLE 8B. PACKAGE DIMENSIONS

SYMBOL	Millimeters	
	Minimum	Maximum
N	24	
A	--	1.20
A1	0.05	0.15
A2	0.80	1.05
b	0.19	0.30
c	0.09	0.20
D	7.70	7.90
E	6.40 BASIC	
E1	4.30	4.50
e	0.65 BASIC	
L	0.45	0.75
α	0°	8°
aaa	--	0.10

Reference Document: JEDEC Publication 95, MO-153



Integrated
Circuit
Systems, Inc.

PRELIMINARY

ICS844246

FEMTOCLOCKS™ CRYSTAL-TO-LVDS

FREQUENCY SYNTHESIZER W/INTEGRATED FANOUT BUFFER

TABLE 9. ORDERING INFORMATION

Part/Order Number	Marking	Package	Shipping Packaging	Temperature
ICS844246AM	TBD	24 Lead SOIC	tube	0°C to 70°C
ICS844246AMT	TBD	24 Lead SOIC	1000 tape & reel	0°C to 70°C
ICS844246AMLF	TBD	24 Lead "Lead-Free" SOIC	tube	0°C to 70°C
ICS844246AMLFT	TBD	24 Lead "Lead-Free" SOIC	1000 tape & reel	0°C to 70°C
ICS844246AG	ICS844246AG	24 Lead TSSOP	tube	0°C to 70°C
ICS844246AGT	ICS844246AG	24 Lead TSSOP	2500 tape & reel	0°C to 70°C
ICS844246AGLF	TBD	24 Lead "Lead-Free" TSSOP	tube	0°C to 70°C
ICS844246AGLFT	TBD	24 Lead "Lead-Free" TSSOP	2500 tape & reel	0°C to 70°C

NOTE: Parts that are ordered with an "LF" suffix to the part number are the Pb-Free configuration and are RoHS compliant.



The aforementioned trademarks, HiPerClockS and FEMTOCLOCKS are trademarks of Integrated Circuit Systems, Inc. or its subsidiaries in the United States and/or other countries. While the information presented herein has been checked for both accuracy and reliability, Integrated Circuit Systems, Incorporated (ICS) assumes no responsibility for either its use or for infringement of any patents or other rights of third parties, which would result from its use. No other circuits, patents, or licenses are implied. This product is intended for use in normal commercial applications. Any other applications such as those requiring extended temperature range, high reliability, or other extraordinary environmental requirements are not recommended without additional processing by ICS. ICS reserves the right to change any circuitry or specifications without notice. ICS does not authorize or warrant any ICS product for use in life support devices or critical medical instruments.