

FPC Connectors for CardBus PC Cards

IC13 Series

PC Card Standard Compliant

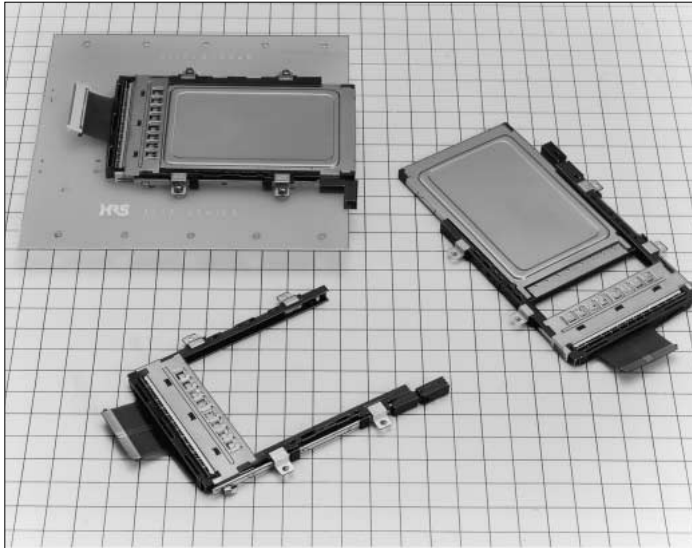

■Features

1. Thinner Equipment Designs are Possible

- (1) Connections are made to the main board via the FPC ^(*Note 1) which permits the PC card slot to be attached directly to the equipment case. The main board can be located at an arbitrary position in the thick direction of the PC card slot which permits thinner equipment designs compared to the on-board type.
- (2) Designed so that the screw ^(*Note 2) heads do not protrude from the main body when fastening to the equipment case.

*Note 1: In combination with multiple contact, 0.3 mm pitch FPC connectors of the 80-contact type (FH16 Series)

*Note 2: When M2 screws are used

2. High Performance Ground

- (1) Configured with 10 CardBus grounds for use with FPC patterns and FPC connectors.
- (2) The entire back surface of the FPC is configured with a ground mesh pattern.

3. High Performance, Dual-End, 2-Point Push Card Ejection Mechanism

These connectors use a dual-end, 2-point push ejection mechanism that pushes the edge surface of the PC card horizontally. This ejection mechanism does not place a stressful load such as a rotational force on the PC card at the time of card ejection and thereby achieves a high level of reliability compared to the 1-point push ejection mechanism.

4. Long card ejection makes card removal easy

(See photograph to the right.)

■Applications

Notebook computers, PDA, etc.

Designed so that screw heads do not protrude from main body



Card in ejected condition



■Product Specifications

Ratings	Operation temperature	-55°C to +85°C (Note 1)	Storage temperature	-40°C to +70°C (Note 2)
	Voltage rating	No. 1 to 68: 30 V AC	Operation humidity	Relative humidity 95% or less (No condensation)
	Current rating	No. 17, 18, 51, 52: 0.5 A, Others: 0.1 A		

Item	Specification	Conditions
1. Withstanding voltage	No flashover or insulation breakdown.	90 V AC/1 minute
2. Insulation resistance	500 M ohms min.	100 V DC
3. Contact resistance	40 mΩ max. (Excluding conductor resistance)	1 mA
4. Mating/un-mating forces	Mating: 39.2N max. Un-mating: 6.67N to 39.2N	With corresponding connector
5. Mechanical operation	(1) Contact resistance:20 m ohms max.from initial value (2) No damage, cracks, or parts looseness.	10000 cycles at 400 to 600 cycles per hour

Note 1:Includes temperature rise caused by current flow.

Note 2:The term "storage" refers to products stored for long period of time prior to mounting and use. Operating Temperature Range and Humidity range covers non- conducting condition of installed connectors in storage, shipment or during transportation.

■Materials

Part	Material	Finish	Remarks
Insulator	PBT	Black	UL94V-0
Contacts	Card connection portion	Brass	Contact: Gold plating
	For ground clips	Stainless steel	-----
	Ground plate	Phosphor bronze	Contact: Gold plating
Eject metal fitting	Stainless steel	-----	-----
Metal fitting	Stainless steel	-----	-----
FPC	Polyamide base	Contact: Solder plating	UL94V-0

Part Number	Weight
IC13T-68D-FEJ*	14.2g

■ Ordering Information

IC13 **T** - **68** **D** - **FEJ** **L**
① ② ③ ④ ⑤ ⑥

<p>① Series name: IC13</p> <p>② FPC type: T</p> <p>③ Number of contacts: 68</p> <p>④ Contact surface of FPC contact portion D: Upper surface (FPC connector board lower surface mounting)</p>	<p>⑤ Eject button type FEJ: Foldering type</p> <p>⑥ Eject button position L: Left R: Right</p>
---	--

■ Corresponding FPC Connector

Part Number	CL No.
FH16-80S-0.3SHW	586-0613-7

Note: Please refer to the FH16 Series catalog for specification details.

■ Mounted Condition

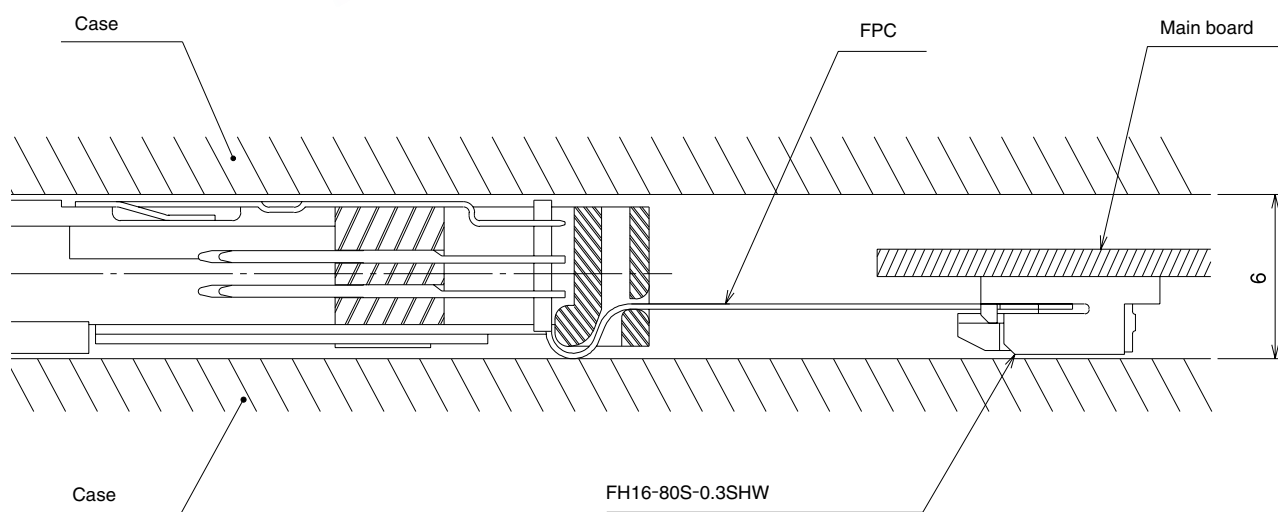

Note : Please request a separate diagram for design purposes.

Left Button Type

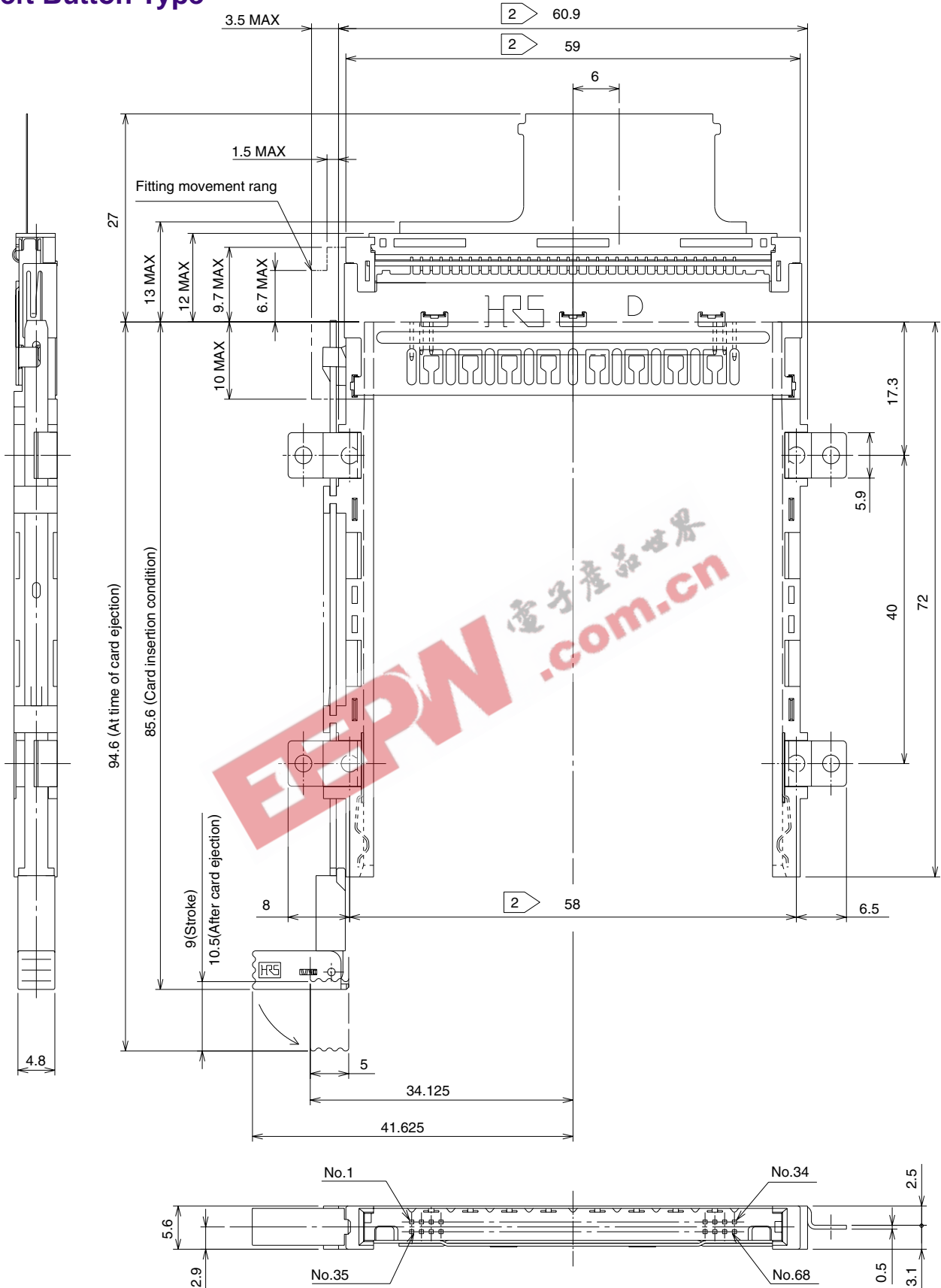

Note 1: Dimensions of the card mating portion conform to the PC Card Standard.

2 The indicated dimensions (at the three locations) are symmetrical about the center of the card insertion slot.

Part Number	CL No.
IC13T-68D-FEJL	640-1201-6

Right Button Type

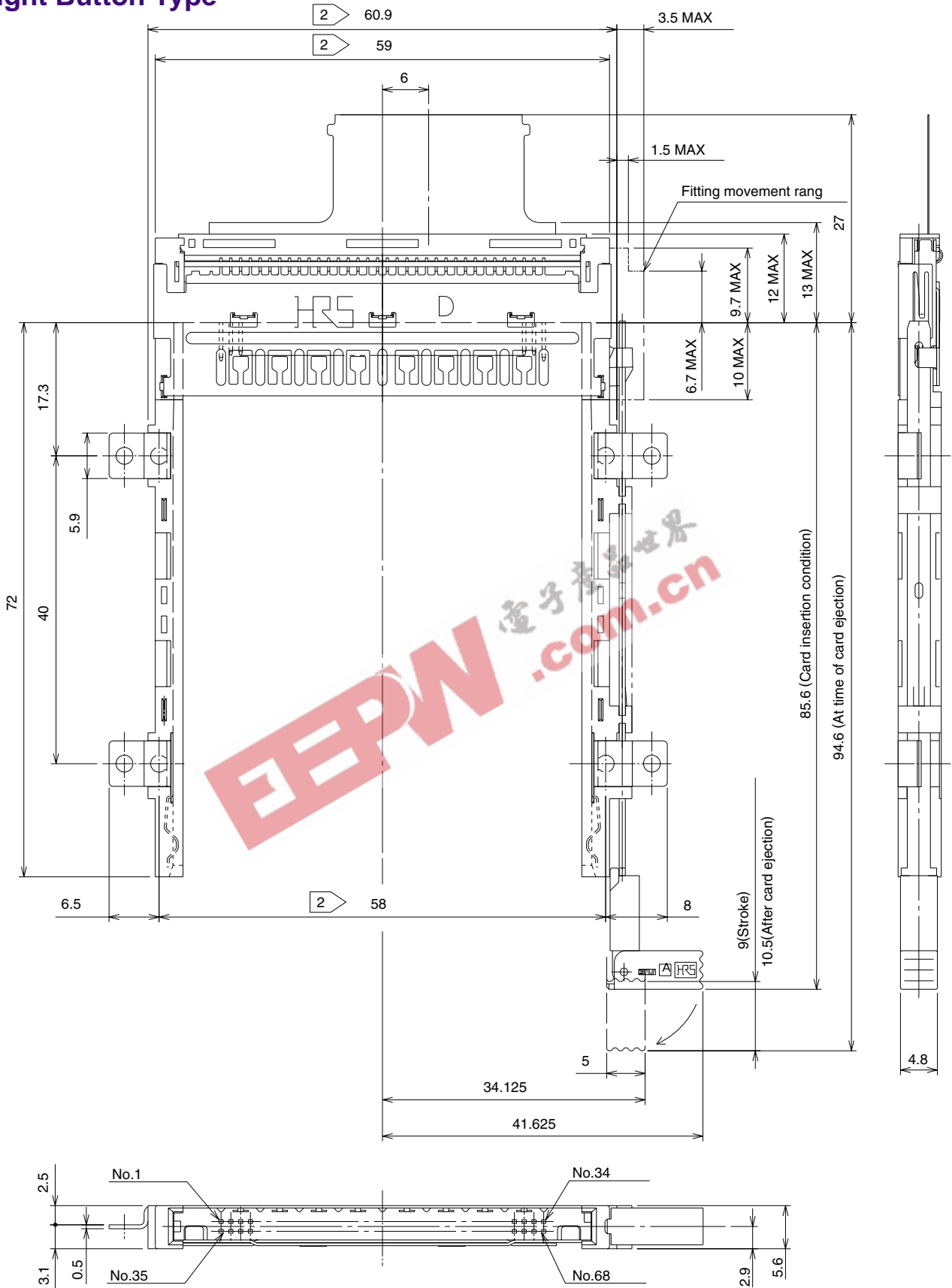

Note 1: Dimensions of the card mating portion conform to the PC Card Standard.

2 The indicated dimensions (at the three locations) are symmetrical about the center of the card insertion slot.

Part Number	CL No.
IC13T-68D-FEJR	640-1202-9

◆PCB mounting pattern

Left Button Type

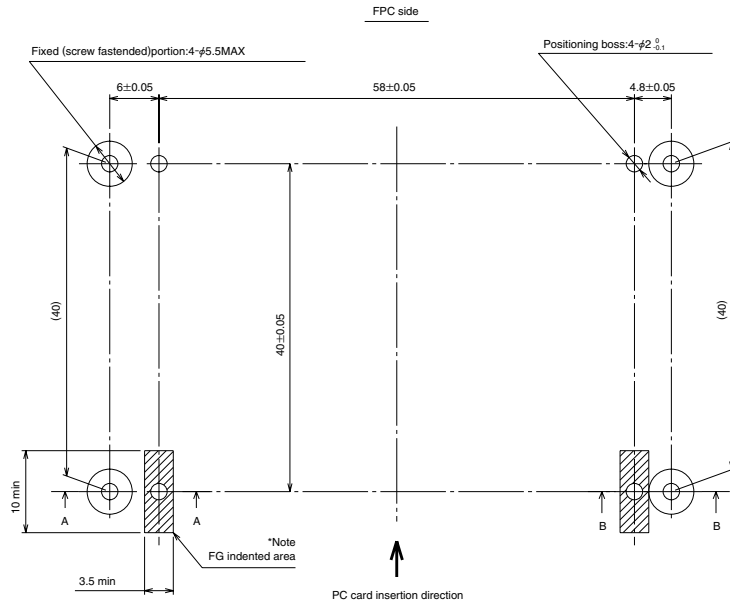

*Note : The FG can also be dropped via the fitting of the fixed (screw fastened) portion.

Right Button Type

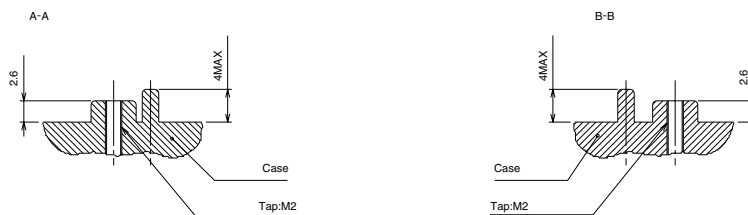
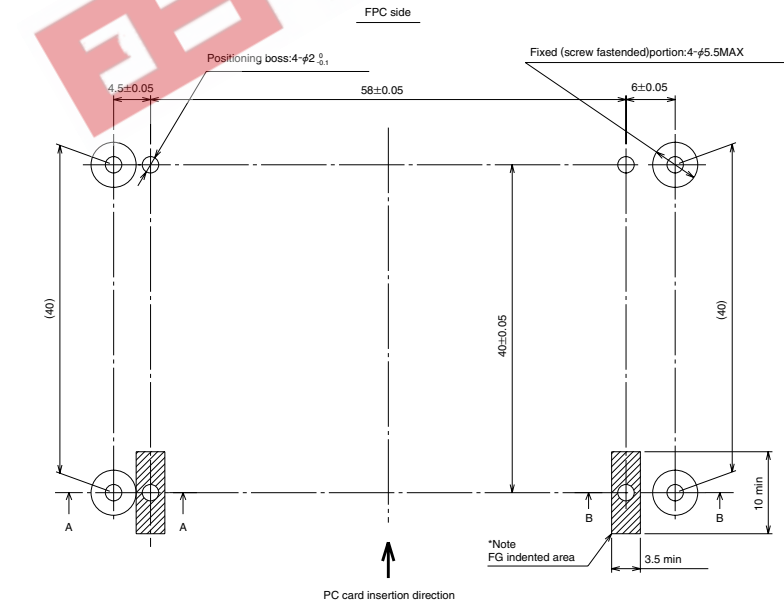

*Note : The FG can also be dropped via the fitting of the fixed (screw fastened) portion.

◆ FPC Connector Land No.

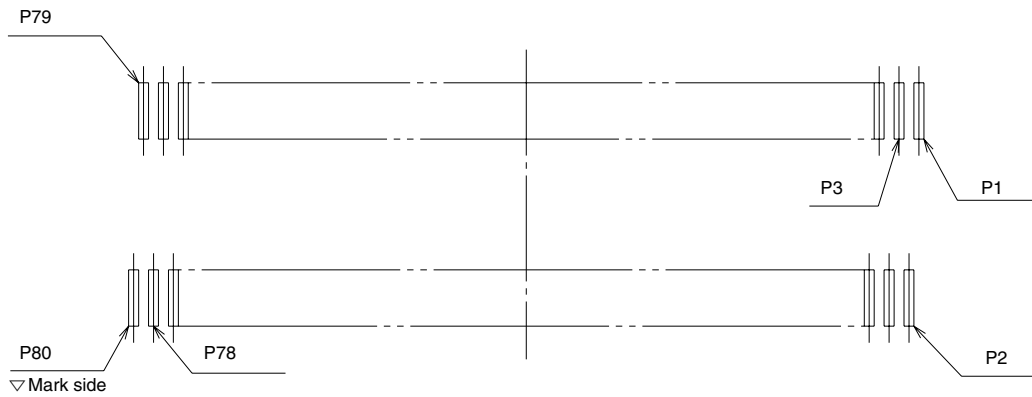

Note: See the FH16-80S-0.3SHW catalog for the land dimensions.

◆ Connection Table

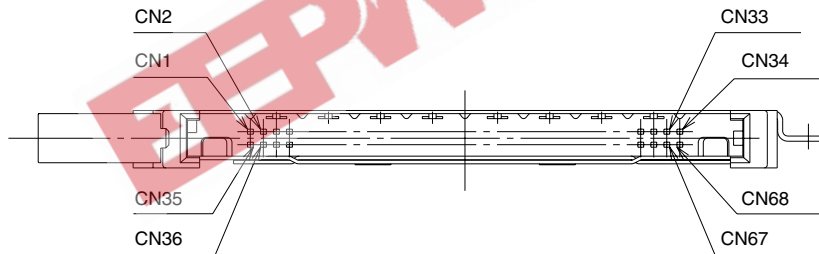

P	CN	P	CN	P	CN	P	CN
1	1(GND)	21	10	41		61	GND
2	35(GND)	22	44	42	18	62	26
3	2	23	11	43		63	60
4	36	24	45	44	52	64	27
5	3	25	12	45		65	61
6	37	26	46	46	19	66	28
7	4	27	13	47	53	67	62
8	38	28	GND	48	20	68	29
9	5	29	47	49	54	69	GND
10	39	30	14	50	21	70	63
11	6	31	48	51	55	71	30
12	GND	32	15	52	22	72	64
13	40	33	49	53	GND	73	31
14	7	34	16	54	56	74	65
15	41	35	50	55	23	75	32
16	8	36		56	57	76	66
17	42	37	17	57	24	77	33
18	9	38		58	58	78	67
19	43	39	51	59	25	79	34(GND)
20	GND	40		60	59	80	68(GND)

◆Method of Mounting to the Equipment

1. Insert the IC13 FPC portion to the FH16 connector (i.e., FPC connector) on an upward angle.

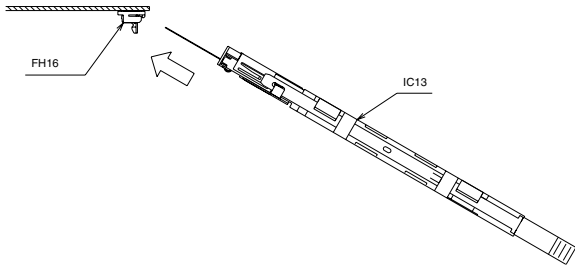

3. Fasten the PC card slot to the case with screws. (M2 screws are recommended.)
Be careful that a load is not placed upon the FPC and FH16 at this time.

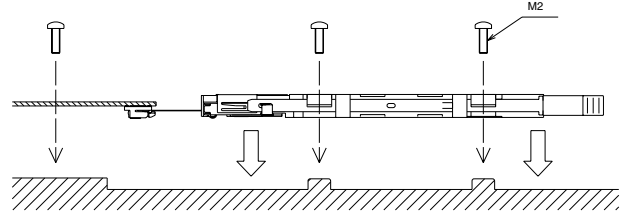

2. Fasten the lock of the FH16 connector (i.e., FPC connector) and connect the FPC portion.

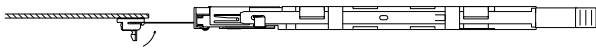

4. Completion

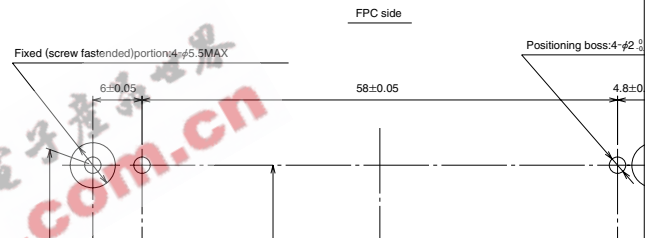

Note: See the FH16 Series catalog for details about the FPC insertion and removal methods.

When handling, please hold the portion indicated by the arrow marks with the button pulled out as illustrated in the diagram below. If the portion connected to the ejection fitting is held with the button pushed in, the fitting might come loose.

