

High Voltage MOSFET

N-Channel, Enhancement Mode

IXTU 01N80

IXTY 01N80

$V_{DSS} = 800 \text{ V}$

$I_{D25} = 100 \text{ mA}$

$R_{DS(on)} = 50 \text{ } \Omega$

Preliminary data sheet

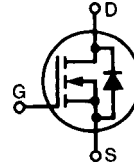

Symbol	Test Conditions	Maximum Ratings 01N100	
V_{DSS}	$T_J = 25^\circ\text{C}$ to 150°C	800	V
V_{DGR}	$T_J = 25^\circ\text{C}$ to 150°C ; $R_{GS} = 1 \text{ M}\Omega$	800	V
V_{GS}	Continuous	± 20	V
V_{GSM}	Transient	± 30	V
I_{D25}	$T_C = 25^\circ\text{C}$; $T_J = 25^\circ\text{C}$ to 150°C	100	mA
I_{DM}	$T_C = 25^\circ\text{C}$, pulse width limited by max. T_J	400	mA
P_D	$T_C = 25^\circ\text{C}$	25	W
T_J		-55 ... +150	$^\circ\text{C}$
T_{JM}		150	$^\circ\text{C}$
T_{stg}		-55 ... +150	$^\circ\text{C}$
T_L	1.6 mm (0.063 in) from case for 5 s	300	$^\circ\text{C}$
Weight		0.8	g

TO-251 AA

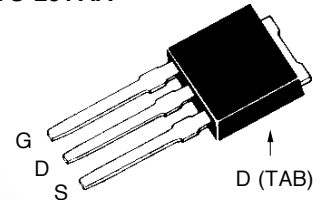

TO-252 AA

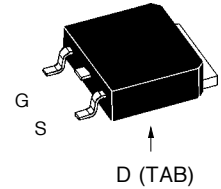

G = Gate, D = Drain, S = Source, TAB = Drain

Symbol	Test Conditions	Characteristic Values ($T_J = 25^\circ\text{C}$, unless otherwise specified)		
		min.	typ.	max.
V_{DSS}	$V_{GS} = 0 \text{ V}$, $I_D = 25 \text{ } \mu\text{A}$	800		V
$V_{GS(th)}$	$V_{DS} = V_{GS}$, $I_D = 25 \text{ } \mu\text{A}$	2		V
I_{GSS}	$V_{GS} = \pm 20 \text{ V}_{DC}$, $V_{DS} = 0$			$\pm 50 \text{ nA}$
I_{DSS}	$V_{DS} = 0.8 V_{DSS}$, $T_J = 25^\circ\text{C}$ $V_{GS} = 0 \text{ V}$, $T_J = 125^\circ\text{C}$			10 μA 200 μA
$R_{DS(on)}$	$V_{GS} = 10 \text{ V}$, $I_D = I_{D25}$ Pulse test, $t \leq 300 \text{ ms}$, duty cycle $d \leq 2 \%$			50 Ω

Features

- International standard packages JEDEC TO-251 AA, TO-252 AA
- Low $R_{DS(on)}$ HDMOS™ process
- Rugged polysilicon gate cell structure
- Fast switching times

Applications

- Level shifting
- Triggers
- Solid state relays
- Current regulators

Symbol	Test Conditions	Characteristic Values		
		(T _J = 25°C, unless otherwise specified)		
		min.	typ.	max.
g_{fs}	V _{DS} = 10 V; I _D = 0.5 I _{D25} , pulse test		140	mS
C_{iss}	V _{GS} = 0 V, V _{DS} = 25 V, f = 1 MHz		60	pF
C_{oss}			8.0	pF
C_{rss}			2.0	pF
t_{d(on)}	V _{GS} = 10 V, V _{DS} = 500 V, I _D = I _{D25} R _G = 50 Ω (External)		12	ns
t_r			12	ns
t_{d(off)}			28	ns
t_f			28	ns
Q_{g(on)}	V _{GS} = 10 V, V _{DS} = 0.5 V _{DSS} , I _D = 0.5 I _{D25}		8	nC
Q_{gs}			1.8	nC
Q_{gd}			3	nC
R_{thJC}			3	K/W

Source-Drain Diode

Symbol	Test Conditions	Characteristic Values		
		(T _J = 25°C, unless otherwise specified)		
		min.	typ.	max.
V_{SD}	I _F = 100 mA, V _{GS} = 0 V, Pulse test, t ≤ 300 μs, duty cycle d ≤ 2 %			1.5 V
t_{rr}	I _F = 0.75 A, -di/dt = 10 A/μs, V _{DS} = 25 V			1.5 μs

TO-251 AA Outline

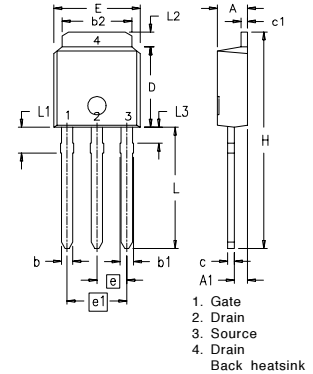

Dim.	Millimeter		Inches	
	Min.	Max.	Min.	Max.
A	2.19	2.38	.086	.094
A1	0.89	1.14	0.35	.045
b	0.64	0.89	.025	.035
b1	0.76	1.14	.030	.045
b2	5.21	5.46	.205	.215
c	0.46	0.58	.018	.023
c1	0.46	0.58	.018	.023
D	5.97	6.22	.235	.245
E	6.35	6.73	.250	.265
e	2.28	BSC	.090	BSC
e1	4.57	BSC	.180	BSC
H	17.02	17.78	.670	.700
L	8.89	9.65	.350	.380
L1	1.91	2.28	.075	.090
L2	0.89	1.27	.035	.050
L3	1.15	1.52	.045	.060

TO-252 AA

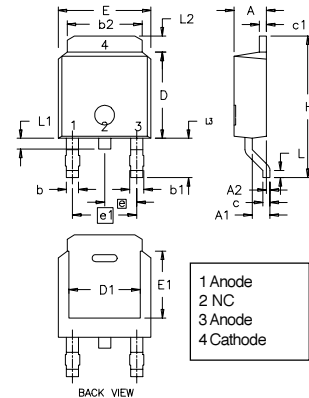

Dim.	Millimeter		Inches	
	Min.	Max.	Min.	Max.
A	2.19	2.38	0.086	0.094
A1	0.89	1.14	0.035	0.045
A2	0	0.13	0	0.005
b	0.64	0.89	0.025	0.035
b1	0.76	1.14	0.030	0.045
b2	5.21	5.46	0.205	0.215
c	0.46	0.58	0.018	0.023
c1	0.46	0.58	0.018	0.023
D	5.97	6.22	0.235	0.245
D1	4.32	5.21	0.170	0.205
E	6.35	6.73	0.250	0.265
E1	4.32	5.21	0.170	0.205
e	2.28	BSC	0.090	BSC
e1	4.57	BSC	0.180	BSC
H	9.40	10.42	0.370	0.410
L	0.51	1.02	0.020	0.040
L1	0.64	1.02	0.025	0.040
L2	0.89	1.27	0.035	0.050
L3	2.54	2.92	0.100	0.115

IXYS reserves the right to change limits, test conditions, and dimensions.

IXYS MOSFETS and IGBTs are covered by one or more of the following U.S. patents: 4,835,592 4,881,106 5,017,508 5,049,961 5,187,117 5,486,715
4,850,072 4,931,844 5,034,796 5,063,307 5,237,481 5,381,025