

HiPerFET™ Power MOSFETs

ISOPLUS247™

F-Class: MegaHertz Switching

(Electrically Isolated Back Surface)

N-Channel Enhancement Mode
Avalanche Rated, High dV/dt
Low Gate Charge and Capacitances

Preliminary Data Sheet

IXFR 12N100F
IXFR 10N100F

V_{DSS}	I_{D25}	$R_{DS(on)}$
1000 V	10 A	1.05 Ω
1000 V	9 A	1.20 Ω

$t_{rr} \leq 250$ ns

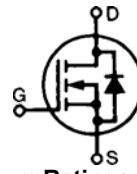

Symbol	Test Conditions	Maximum Ratings	
V_{DSS}	$T_J = 25^\circ\text{C}$ to 150°C	1000	V
V_{DGR}	$T_J = 25^\circ\text{C}$ to 150°C ; $R_{GS} = 1$ M Ω	1000	V
V_{GS}	Continuous	± 20	V
V_{GSM}	Transient	± 30	V
I_{D25}	$T_C = 25^\circ\text{C}$	12N100 10 10N100 9	A A
I_{DM}	$T_C = 25^\circ\text{C}$, Pulse width limited by T_{JM}	12N100 48 10N100 40	A A
I_{AR}	$T_C = 25^\circ\text{C}$	12N100 12 10N100 10	A A
E_{AR}	$T_C = 25^\circ\text{C}$	31	mJ
E_{AS}	$T_C = 25^\circ\text{C}$	1	J
dv/dt	$I_S \leq I_{DM}$, $di/dt \leq 100$ A/ μs , $V_{DD} \leq V_{DSS}$ $T_J \leq 150^\circ\text{C}$, $R_G = 2$ Ω	5	V/ns
P_D	$T_C = 25^\circ\text{C}$	250	W
T_J		-40 ... +150	$^\circ\text{C}$
T_{JM}		150	$^\circ\text{C}$
T_{stg}		-40 ... +150	$^\circ\text{C}$
T_L	1.6 mm (0.063 in.) from case for 10 s	300	$^\circ\text{C}$
V_{ISOL}	50/60 Hz, RMS $t = 1$ min	2500	V~
Weight		5	g

ISOPLUS 247™ (IXFR)

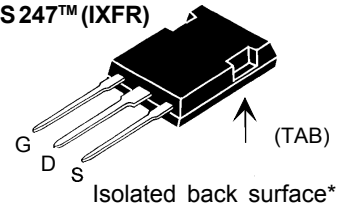

G = Gate D = Drain
S = Source TAB = Drain

Features

- RF capable MOSFETs
- Double metal process for low gate resistance
- Unclamped Inductive Switching (UIS) rated
- Low package inductance - easy to drive and to protect
- Fast intrinsic rectifier

Applications

- DC-DC converters
- Switched-mode and resonant-mode power supplies, >500kHz switching
- DC choppers
- 13.5 MHz industrial applications
- Pulse generation
- Laser drivers
- RF amplifiers

Advantages

- ISOPLUS 247™ package for clip or spring mounting
- Space savings
- High power density

Symbol	Test Conditions	Characteristic Values ($T_J = 25^\circ\text{C}$, unless otherwise specified)		
		min.	typ.	max.
V_{DSS}	$V_{GS} = 0$ V, $I_D = 1$ mA	1000		V
$V_{GS(th)}$	$V_{DS} = V_{GS}$, $I_D = 4$ mA	3.0		5.5 V
I_{GSS}	$V_{GS} = \pm 20$ V, $V_{DS} = 0$			± 100 nA
I_{DSS}	$V_{DS} = V_{DSS}$ $V_{GS} = 0$ V	$T_J = 25^\circ\text{C}$ $T_J = 125^\circ\text{C}$		50 μA 1.5 mA
$R_{DS(on)}$	$V_{GS} = 10$ V, $I_D = I_T$ Notes 1 & 2	12N100 10N100		1.05 Ω 1.2 Ω

Symbol	Test Conditions	Characteristic Values ($T_J = 25^\circ\text{C}$, unless otherwise specified)	Characteristic Values		
			min.	typ.	max.
g_{fs}	$V_{DS} = 10\text{ V}; I_D = I_T$	Note 1	8	12	S
C_{iss}	$V_{GS} = 0\text{ V}, V_{DS} = 25\text{ V}, f = 1\text{ MHz}$			2700	pF
C_{oss}				305	pF
C_{rss}				93	pF
$t_{d(on)}$	$V_{GS} = 10\text{ V}, V_{DS} = 0.5 \cdot V_{DSS}, I_D = I_T$ $R_G = 2\ \Omega$ (External)			12	ns
t_r				9.8	ns
$t_{d(off)}$				31	ns
t_f				12	ns
$Q_{g(on)}$	$V_{GS} = 10\text{ V}, V_{DS} = 0.5 \cdot V_{DSS}, I_D = I_T$			77	nC
Q_{gs}				16	nC
Q_{gd}				42	nC
R_{thJC}				0.50	K/W
R_{thCK}			0.15		K/W

Source-Drain Diode

Symbol	Test Conditions	Characteristic Values ($T_J = 25^\circ\text{C}$, unless otherwise specified)			
		min.	typ.	max.	
I_S	$V_{GS} = 0\text{ V}$			12 A	
I_{SM}	Repetitive; pulse width limited by T_{JM}			48 A	
V_{SD}	$I_F = I_S, V_{GS} = 0\text{ V}$, Note 1			1.5 V	
t_{rr}	$I_F = 25\text{ A}, -di/dt = 100\text{ A}/\mu\text{s}, V_R = 100\text{ V}$			250 ns	
Q_{RM}				0.8	μC
I_{RM}				7	A

- Note: 1. Pulse test, $t \leq 300\ \mu\text{s}$, duty cycle $d \leq 2\%$
 2. I_T test current: IXFR10N100 $I_T = 5\text{ A}$
 IXFR12N100 $I_T = 6\text{ A}$

PLUS 247™ Outline

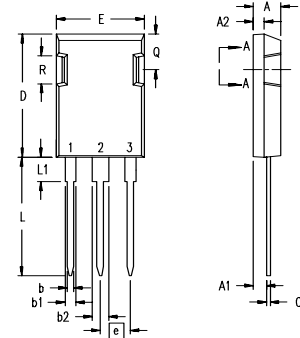

- Terminals:
 1 - Gate
 2 - Drain (Collector)
 3 - Source (Emitter)
 4 - Drain (Collector)

Dim.	Millimeter		Inches	
	Min.	Max.	Min.	Max.
A	4.83	5.21	.190	.205
A ₁	2.29	2.54	.090	.100
A ₂	1.91	2.16	.075	.085
b	1.14	1.40	.045	.055
b ₁	1.91	2.13	.075	.084
b ₂	2.92	3.12	.115	.123
C	0.61	0.80	.024	.031
D	20.80	21.34	.819	.840
E	15.75	16.13	.620	.635
e	5.45 BSC		.215 BSC	
L	19.81	20.32	.780	.800
L ₁	3.81	4.32	.150	.170
Q	5.59	6.20	.220	0.244
R	4.32	4.83	.170	.190