

Negative Voltage Hot Swap Controller with Active Power Filter

Active Power Filter only Evaluation Board

Although the IXHQ100 incorporates all the functions necessary to implement a state of the art negative voltage hot swap, a key feature of the IXHQ100 is its Power Active Filter. For those size and cost sensitive applications requiring only a Power Active Filter, the evaluation board schematic is given in Figure 1, with bill of materials in Figure 4. Figure 2 is a ripple rejection plot of the Power Active Filter placed in the test circuit provided in Figure 3.

- Some of the advantages of a Power Active Filter over standard passive filters are:
- * Significantly reduced size of the power supply bypass capacitors.
 - * Eliminate magnetic noise generation by eliminating the need for power filter inductors.
 - * Reduced sensitivity to power supply noise.
 - * Reduce size, weight, and overall system cost.

ACTIVE POWER FILTER

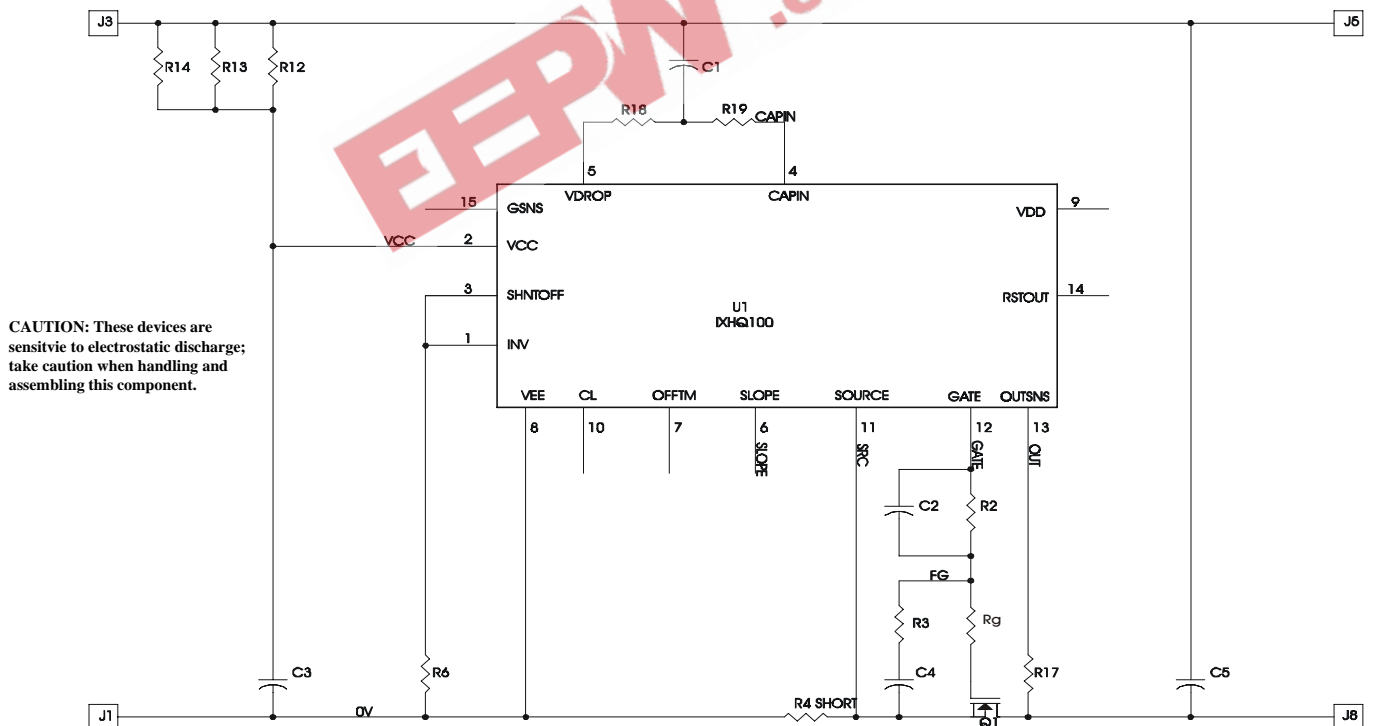

Figure 1

Typical Ripple Noise Attenuation

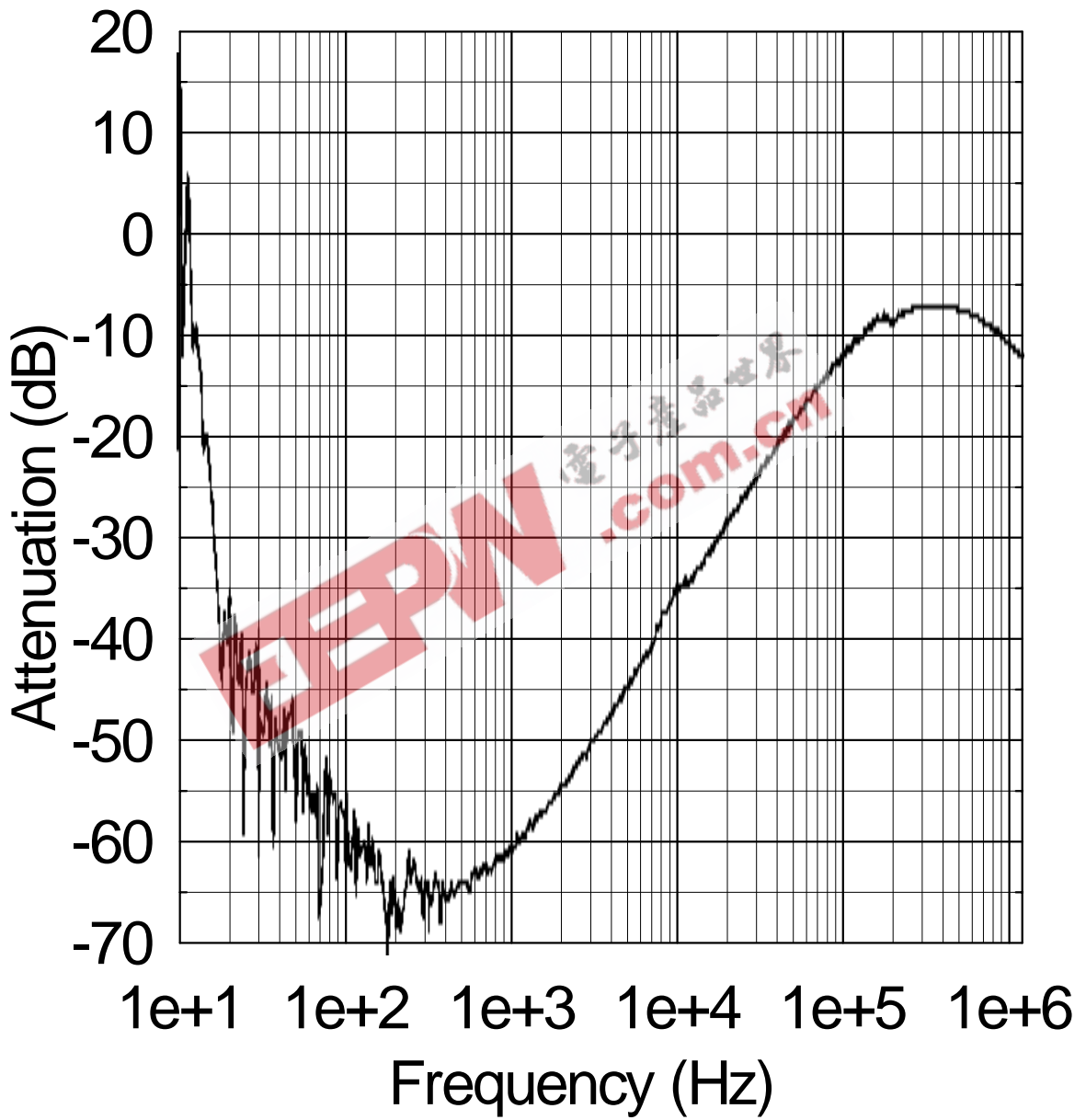

Figure 2

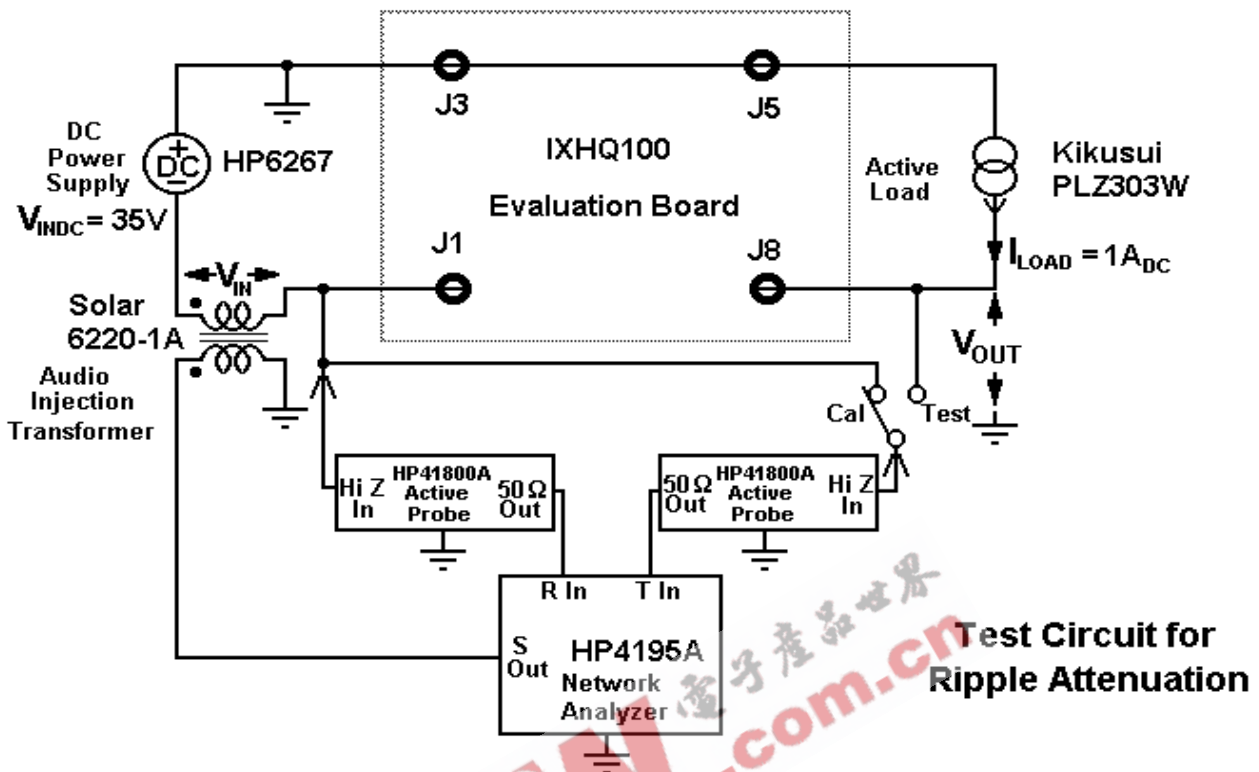

Figure 3

Bill of Materials

Item	Reference Number	Part Value
1	C1	10uF/100V TH
2	C2	3.3nF 25V 0805
3	C3	10uF/25V TH
4	C4	10uF/16V TH
5	C5	100uF/100V TH
6	Q1	IRF2807S D2
7	R2	10 Kohm 0.1W att 0805
8	R3	3 Kohm 0.1W att 0805
9	R6	0 ohm 0.1W att 0805
10	R7	0 ohm 0.1W att 0805
11	R12	16 Kohm 0.1W att 0805
12	R13	16 Kohm 0.1W att 0805
13	R14	16 Kohm 0.1W att 0805
14	R17	10 Kohm 0.1W att 0805
15	R18	10 Kohm 0.1W att 0805
16	R19	100 kohm 0.1W att 0805
17	Rg	10 ohm 0.1W att 0805
18	U1	IXHQ100

Figure 4

Using the IXHQ100 active filter minimizes the number of extra de-coupling capacitors. This improves noise immunity of the circuit board. Additionally, low output impedance of the filter also improves the performance of noise cancellation on power lines. An extra advantage of using the IXHQ100 over capacitors is the amount of space one can save. Figure 6 gives an example of cross talk noise cancellation by the IXHQ100 and an comparison of the size difference between an IXHQ100 chip and a capacitor (to scale).

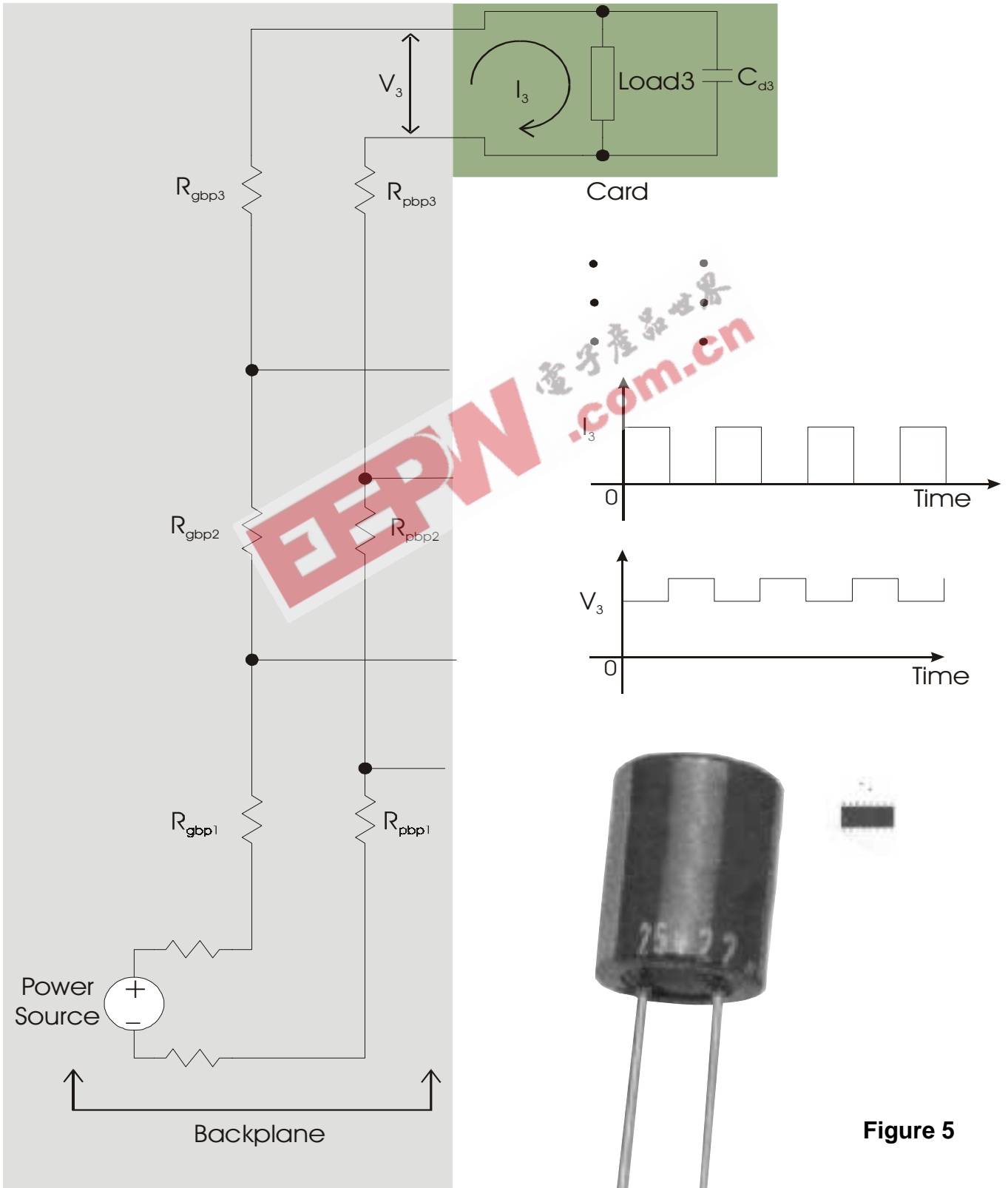

Figure 5