

PULSEJACK™

1xN GangjackL



www.pulseeng.com

Description:

10/100 Base-TX RJ45 1xN Tab-DOWN with or without LEDs integrated magnetics connector (ICM) designed to support applications such as: SOHO (ADSL modems), LAN-on-Motherboard (LOM), Hub and Switches.



Features and Benefits:

- ⊕ RoHS-5 peak wave solder temperature rating 235°C
- ⊕ RoHS-6 peak wave solder temperature rating 260°C
- ⊕ RJ45 1xN, Tab-DOWN 8-pin with internal magnetics
- ⊕ Suitable for CAT 5 and 6 Fast Ethernet cable or better UTP
- ⊕ Internal magnetics: 100% electrically tested for HI-POT and functionality

Electrical Performance Summary:

- ⊕ Meets IEEE 802.3 specification
- ⊕ 350µH minimum OCL with 8mA bias current
- ⊕ High performance for maximum EMI suppression

Electrical Specifications @ 25°C — Operating Temperature 0°C to +70°C

RoHS-5 Compliant ² Part Number (Number of Ports)	RoHS-6 Compliant ³ Part Number (Number of Ports)	Turns Ratios		Tab Option	LEDs ¹ L/R	Insertion Loss TX/RX (dB TYP)	Return Loss (dB TYP) 100Ω (±15Ω)				Crosstalk (dB TYP)			Common Mode Rejection (dB TYP)		Hipot (Vrms MIN)
		TX	RX				1-100 MHz	1-10 MHz	30 MHz	60-80 MHz	1-10 MHz	30-60 MHz	60-100 MHz	1-50 MHz	50-130 MHz	
J8064D628A (1x2)	J8064D628ANL (1x2)	1CT:1CT	1CT:1CT	DOWN	G/Y	-1.0	-20	-16	-12	-40	-35	-30	-30	-20	1500	
J8064D648A (1x4)	J8064D648ANL (1x4)	1CT:1CT	1CT:1CT	DOWN	G/Y	-1.0	-20	-16	-12	-40	-35	-30	-30	-20	1500	
J8064D668A (1x6)	J8064D668ANL (1x6)	1CT:1CT	1CT:1CT	DOWN	G/Y	-1.0	-20	-16	-12	-40	-35	-30	-30	-20	1500	
J8064D688A (1x8)	J8064D688ANL (1x8)	1CT:1CT	1CT:1CT	DOWN	G/Y	-1.0	-20	-16	-12	-40	-35	-30	-30	-20	1500	
J8064E62 (1x2)	J8064E62NL (1x2)	1CT:1CT	1CT:1CT	DOWN	—	-1.0	-20	-16	-12	-40	-35	-30	-30	-20	1500	
J8064E64 (1x4)	J8064E64NL (1x4)	1CT:1CT	1CT:1CT	DOWN	—	-1.0	-20	-16	-12	-40	-35	-30	-30	-20	1500	
J8064E66 (1x6)	J8064E66NL (1x6)	1CT:1CT	1CT:1CT	DOWN	—	-1.0	-20	-16	-12	-40	-35	-30	-30	-20	1500	
J8064E68 (1x8)	J8064E68NL (1x8)	1CT:1CT	1CT:1CT	DOWN	—	-1.0	-20	-16	-12	-40	-35	-30	-30	-20	1500	

NOTES:

1. LEDs Left/Right: G = green; Y = yellow; "—" = none. Other LED options by request.
2. RoHS-5 - Product does not contain 5 out of the 6 banned substances specified in the RoHS directive. Product contains lead in applications considered as solders.
3. RoHS-6 - Product does not contain 5 out of the 6 banned substances specified in the RoHS directive. Some internal connections may contain lead in high temperature solder (solder alloys containing more than 85% lead).

RJ45 Durability Testing Rating

Part Number	Mating Force (MAX)	Unmating Force (MAX)	Durability	Plug to Jack Retention (MIN)
J8 Series	5lbs./2.268kgs.	5lbs./2.268kgs.	750 Insertions	20lbs./9.072kgs.

RJ45 Material Specification

Part Number	Shield		Contact			Housing		MSL ² Rating
	Material	Finish	Material	Plating Area	Solder Area ³	Material	Specification	
J8 Series	Brass	10-20µ inches thick nickel over 10-20µ inches thick nickel	Phosphor Bronze	30µ inches gold over 30-80µ inches nickel	75-300µ inches tin-lead over 30-80µ inches bright nickel	Thermoplastic	UL 94 V-0	1

- Notes: 1. Connector dimensions comply with FCC dimension requirements. 2. MSL = Moisture Sensitivity Level rating from 1 to 5 (highest rating = 1, lowest rating = 5). 3. NL parts are tin matte finish over nickel.

Mechanicals

J8064D628A

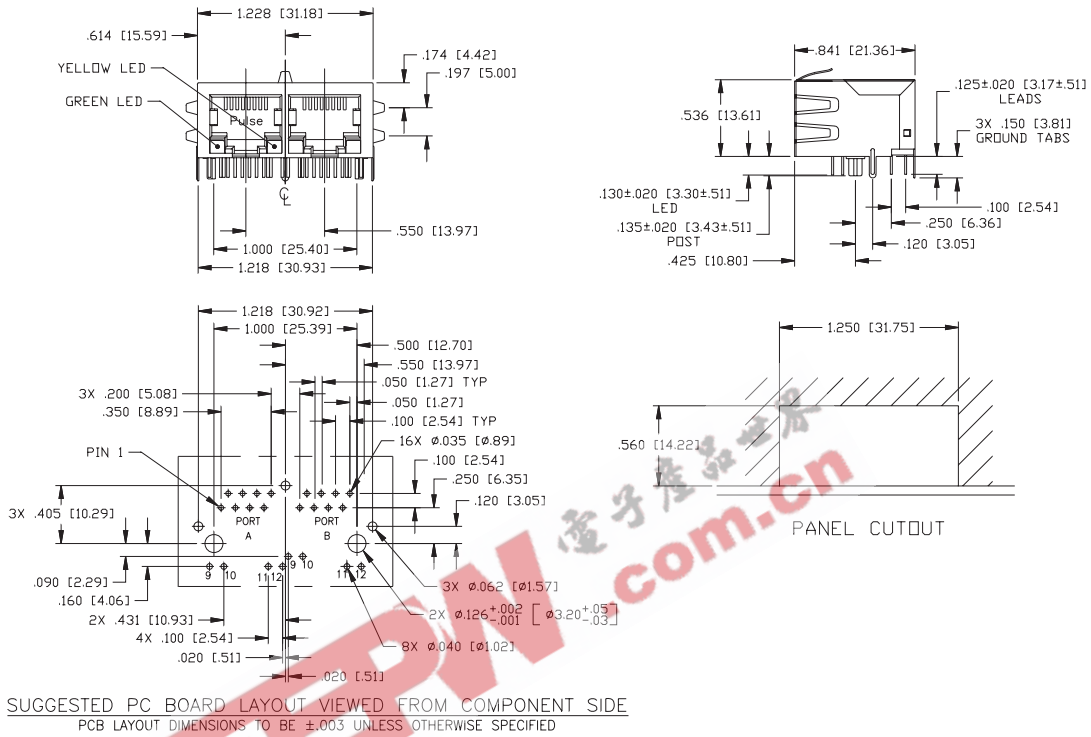

J8064E62

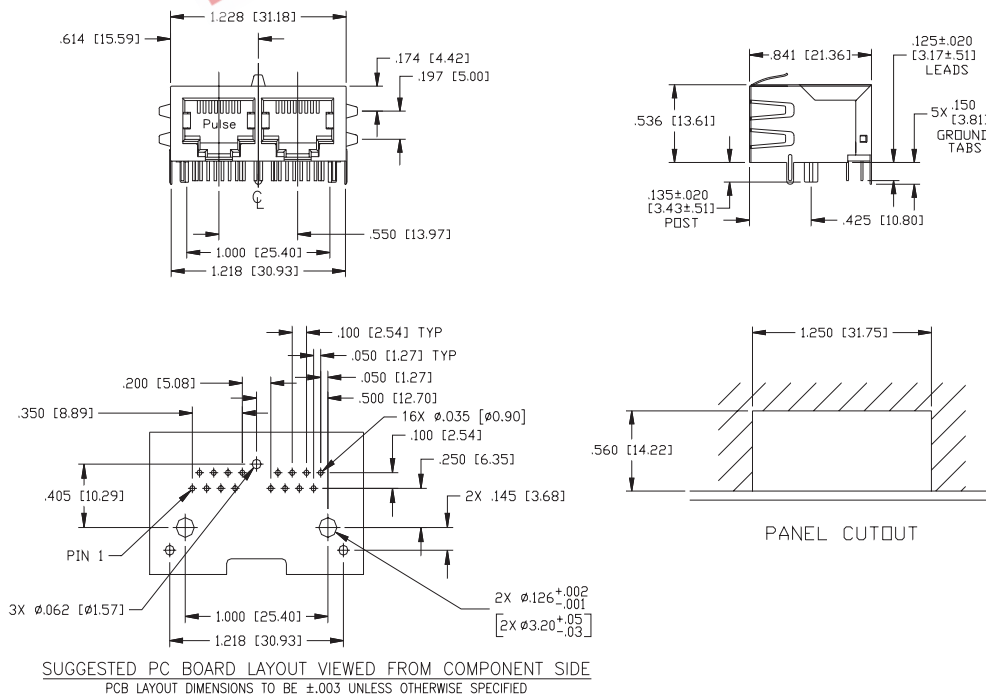

PULSEJACK™

1xN GangjackL



Mechanicals

J8064D648A

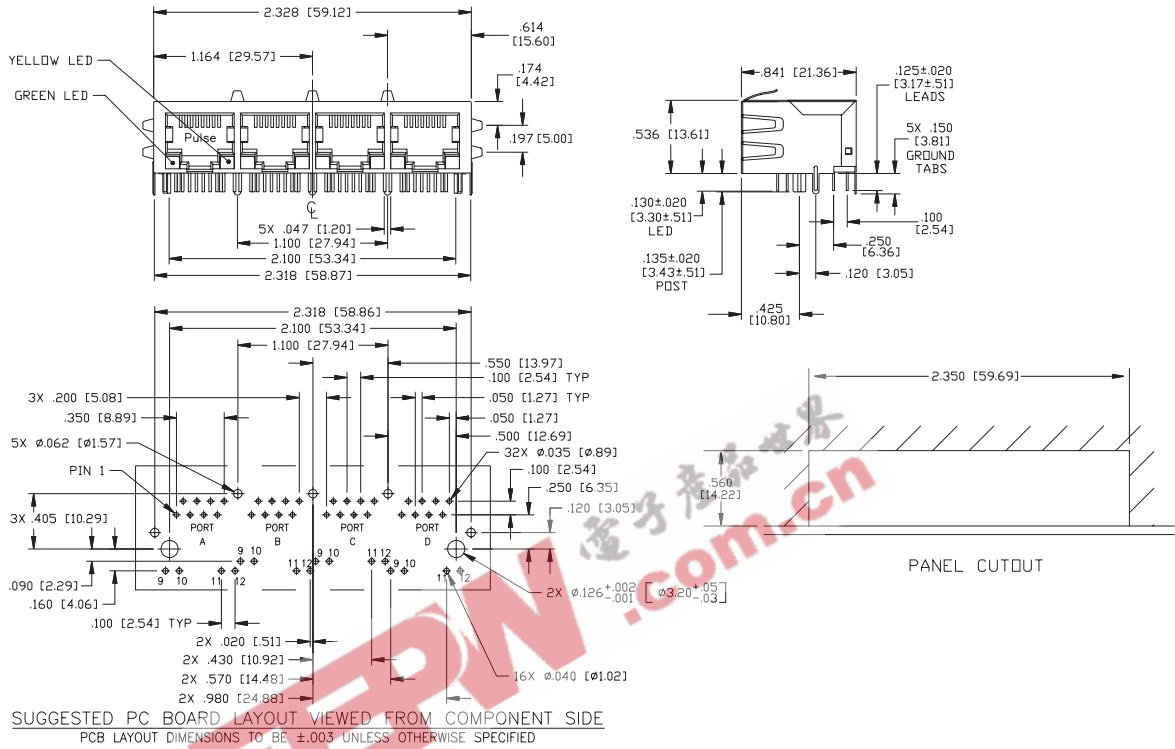

J8064E64

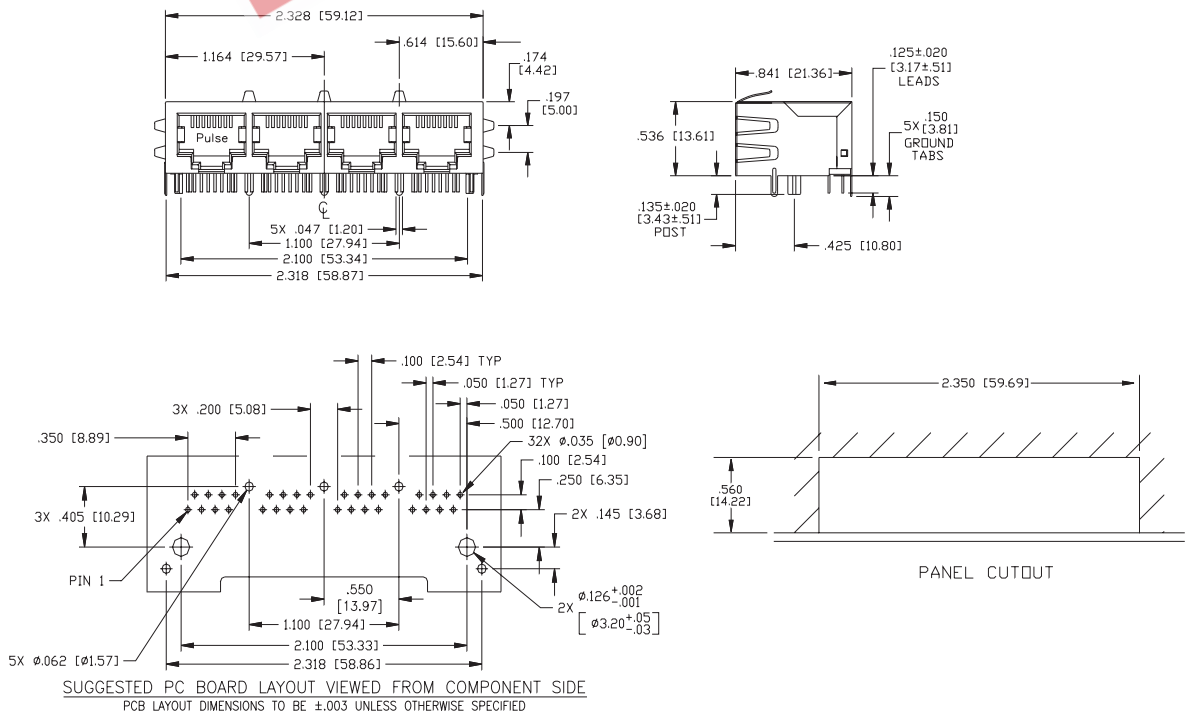



Mechanicals

J8064D668A

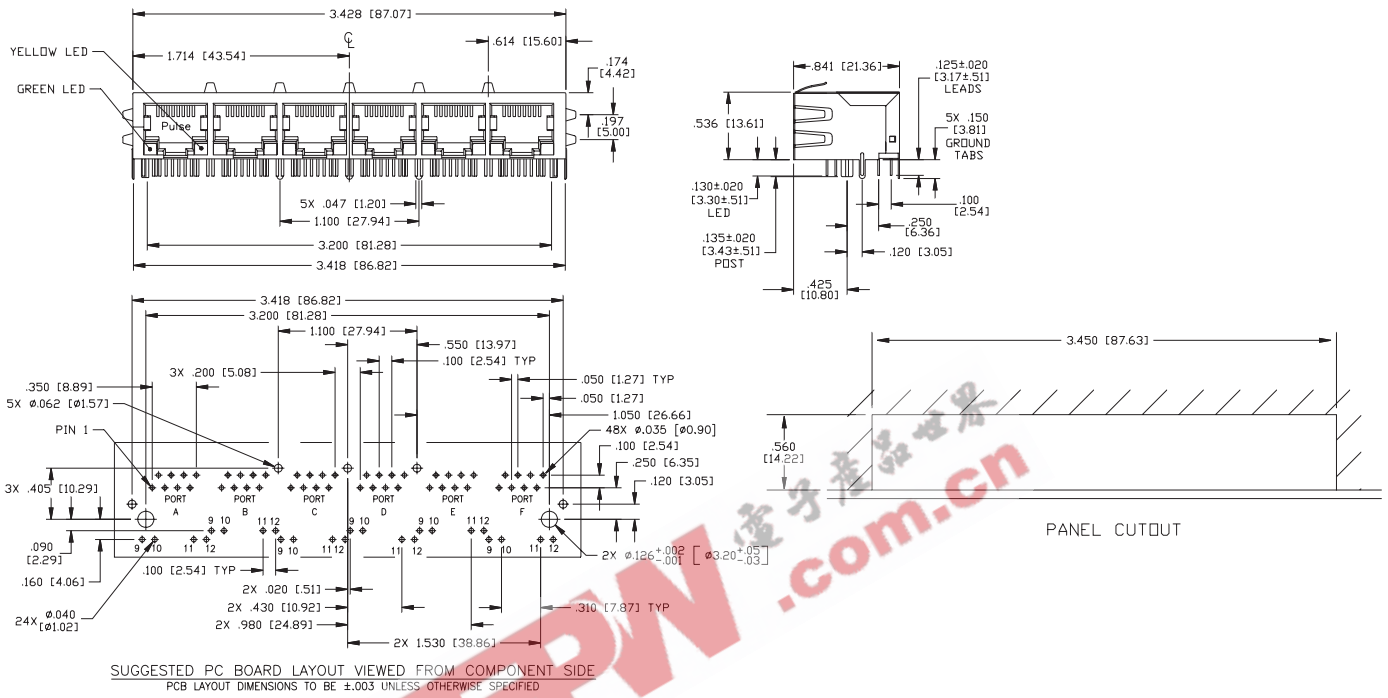

J8064E66

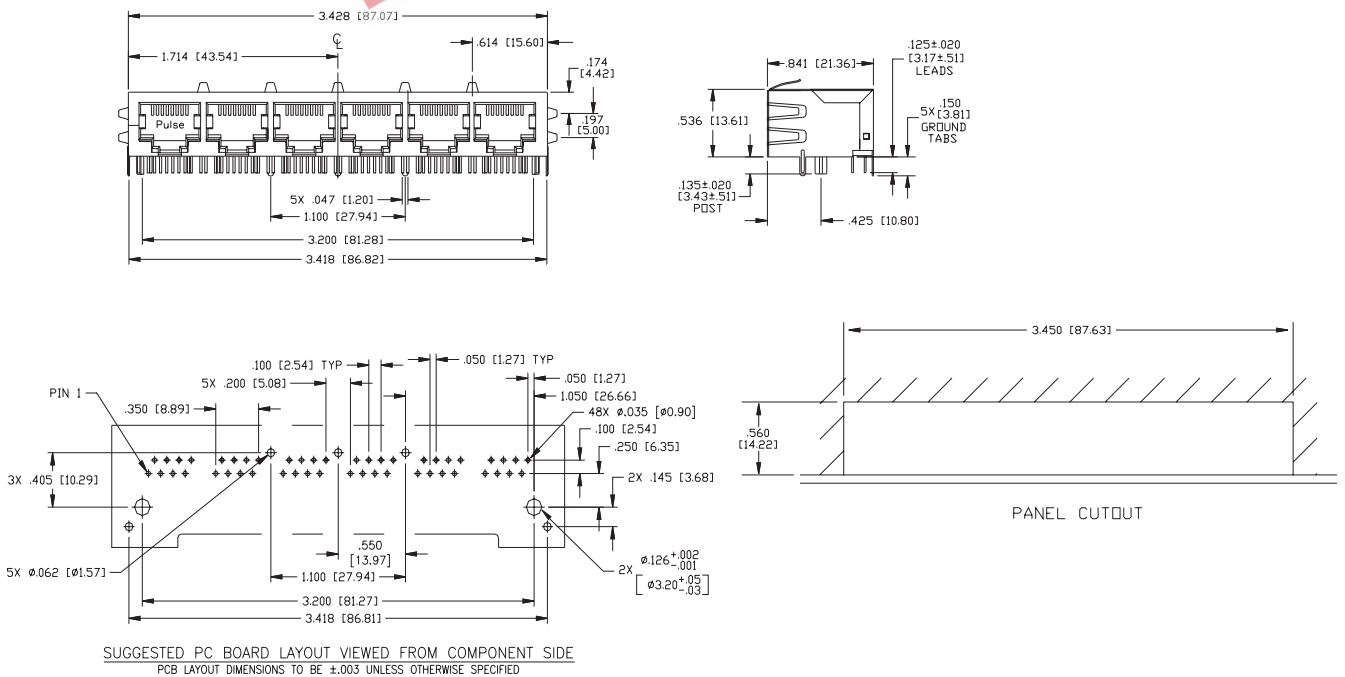

Mechanicals

J8064D688A

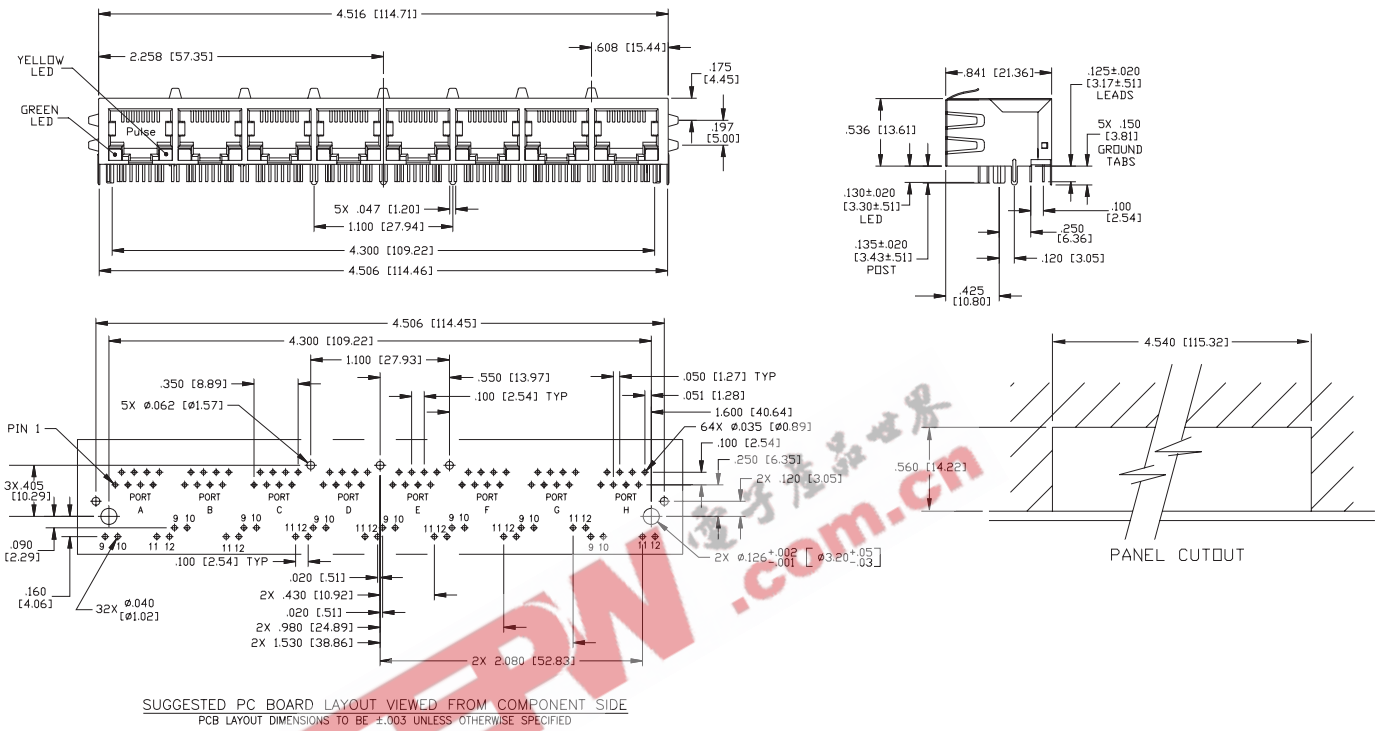

J8064E68

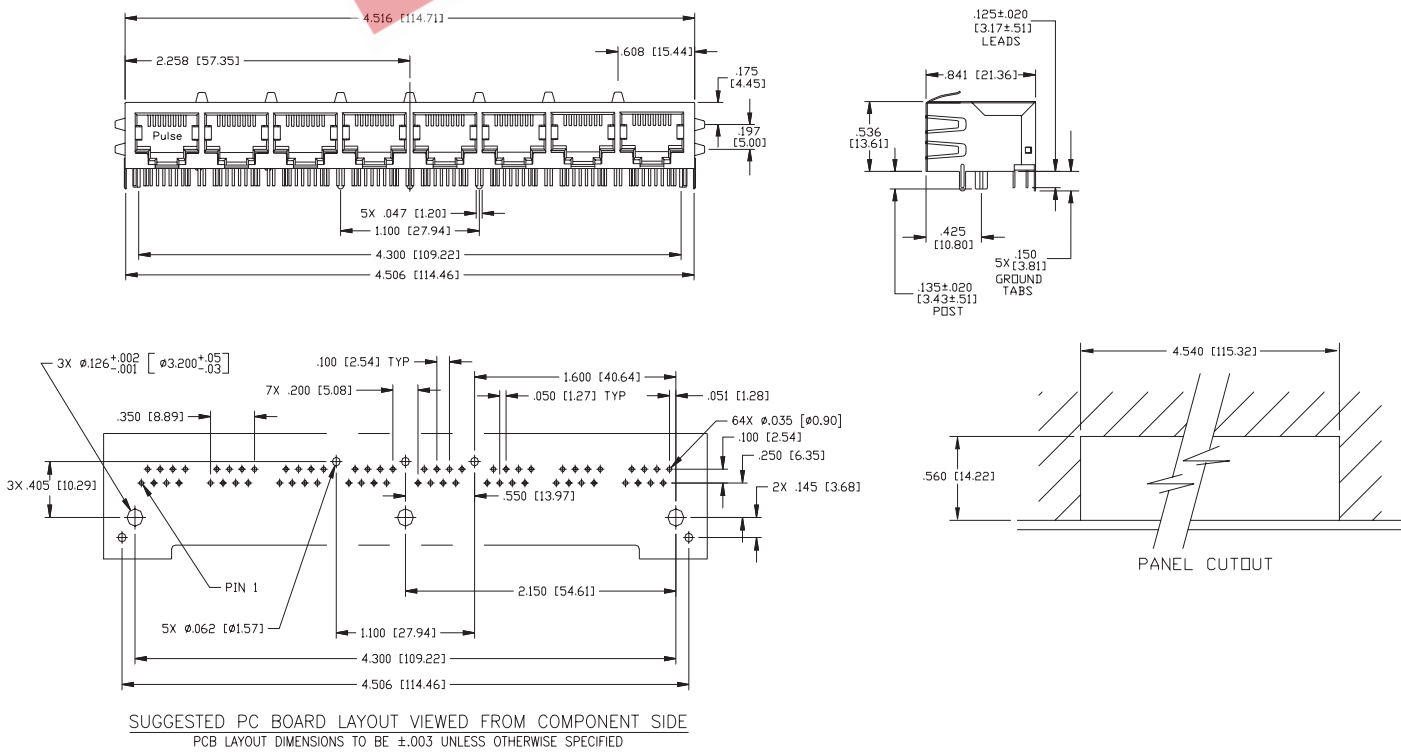

Schematic for J8 Series

J8064D6X8A/J8064E6X (where X = 2, 4, 6 or 8)

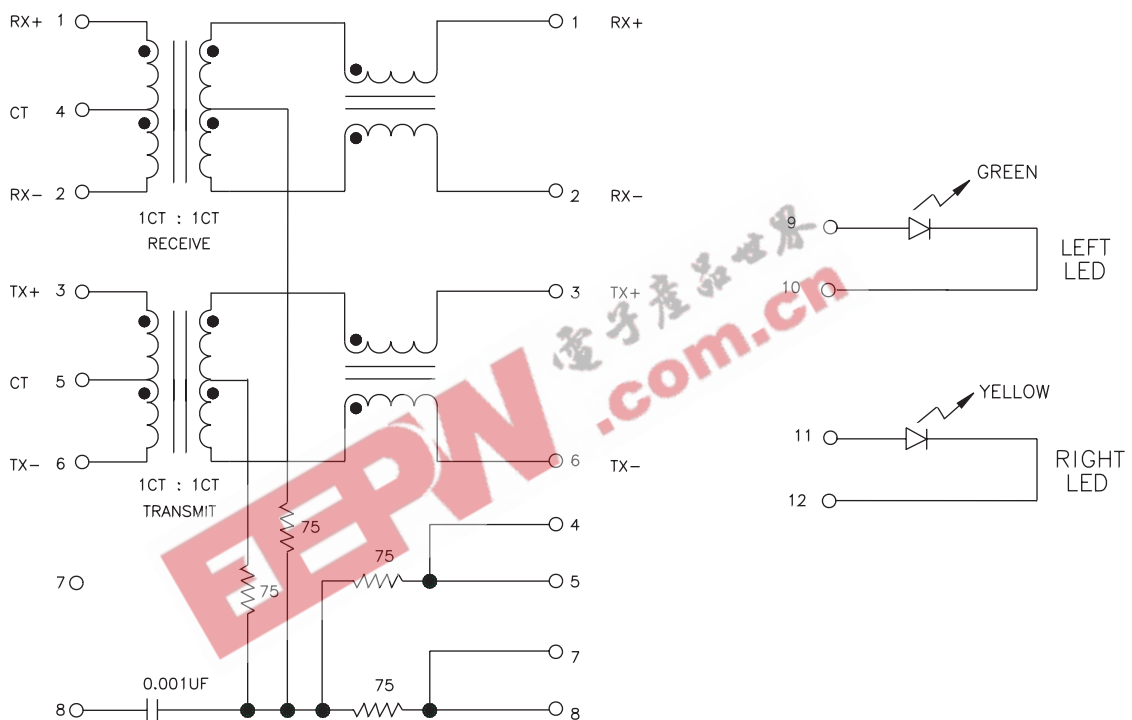

	1X2	1X4	1X6	1X8
	J8064D628A	J8064D648A	J8064D668A	J8064D688A
	J8064E62	J8064E64	J8064E66	J8064E68
Weight	10.9 grams	21.8 grams	32.7 grams	43.6 grams
Tray	10 /tray	10 /tray	10 /tray	10 /tray

For More Information:

Pulse Worldwide Headquarters

12220 World Trade Drive
San Diego, CA 92128
U.S.A.
www.pulseeng.com
TEL: 858 674 8100
FAX: 858 674 8262

Pulse Northern Europe

3 Huxley Road
Surrey Research Park
Guildford, Surrey GU2 5RE
United Kingdom
TEL: 44 1483 401700
FAX: 44 1483 401701

Pulse Southern Europe

Zone Industrielle
F-39270
Orgelet
France
TEL: 33 3 84 35 04 04
FAX: 33 3 84 25 46 41

Pulse China Headquarters

No. 1
Industrial District
Changan, Dongguan
China
TEL: 86 769 85538070
FAX: 86 769 85538870

Pulse North China

Room 1503
XinYin Building
No. 888 YiShan Road
Shanghai 200233
China
TEL: 86 21 54643211/2
FAX: 86 21 54643210

Pulse South Asia

150 Kampong Ampat
#07-01/02
KA Centre
Singapore 368324
TEL: 65 6287 8998
FAX: 65 6280 0080

Pulse North Asia

No. 26
Kao Ching Road
Yang Mei Chen
Taoyuan Hsien
Taiwan, R. O. C.
TEL: 886 3 4641811
FAX: 886 3 4641911

Performance warranty of products offered on this data sheet is limited to the parameters specified. Data is subject to change without notice. Other brand and product names mentioned herein may be trademarks or registered trademarks of their respective owners.
© Copyright, 2006. Pulse Engineering, Inc. All rights reserved.