

SDLS037

DUAL J-K POSITIVE-EDGE-TRIGGERED FLIP-FLOPS WITH PRESET AND CLEAR

**SN54109, SN54LS109A,
SN74109, SN74LS109A**

DECEMBER 1983 — REVISED MARCH 1988

- Package Options Include Plastic "Small Outline" Packages, Ceramic Chip Carriers and Flat Packages, and Plastic and Ceramic DIPs
- Dependable Texas Instruments Quality and Reliability

description

These devices contain two independent J-K positive-edge-triggered flip-flops. A low level at the preset or clear inputs sets or resets the outputs regardless of the levels of the other inputs. When preset and clear are inactive (high), data at the J and K inputs meeting the setup time requirements are transferred to the outputs on the positive-going edge of the clock pulse. Clock triggering occurs at a voltage level and is not directly related to the rise time of the clock pulse. Following the hold time interval, data at the J and K inputs may be changed without affecting the levels at the outputs. These versatile flip-flops can perform as toggle flip-flops by grounding K and tying J high. They also can perform as D-type flip-flops if J and K are tied together.

The SN54109 and SN54LS109A are characterized for operation over the full military temperature range of -55°C to 125°C. The SN74109 and SN74LS109A are characterized for operation from 0°C to 70°C.

SN54109, SN54LS109A . . . J OR W PACKAGE
SN74109 . . . N PACKAGE
SN74LS109A . . . D OR N PACKAGE
(TOP VIEW)

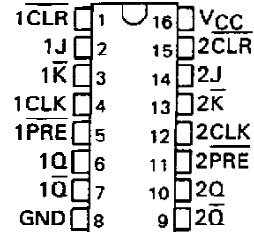

SN54LS109A . . . FK PACKAGE
(TOP VIEW)

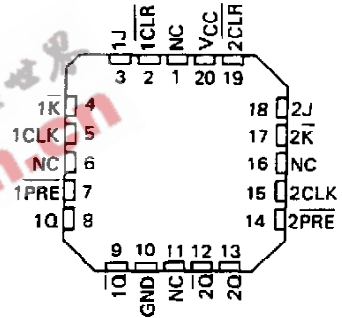

FUNCTION TABLE (each flip-flop)

INPUTS					OUTPUTS	
PRE	CLR	CLK	J	K	Q	Q̄
L	H	X	X	X	H	L
H	L	X	X	X	L	H
L	L	X	X	X	H†	H†
H	H	↑	L	L	L	H
H	H	↑	H	L	TOGGLE	
H	H	↑	L	H	Q ₀	Q̄ ₀
H	H	↑	H	H	H	L
H	H	L	X	X	Q ₀	Q̄ ₀

† The output levels in this configuration are not guaranteed to meet the minimum levels for V_{OH} if the lows at preset and clear are near V_{IL} maximum. Furthermore, this configuration is nonstable; that is, it will not persist when preset or clear return to their inactive (high) level.

logic symbol†

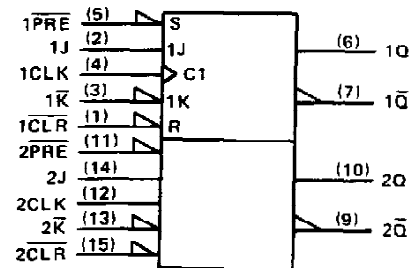

† This symbol is in accordance with ANSI/IEEE Std 91-1984 and IEC Publication 617-12.

Pin numbers shown are for D, J, N, and W packages.

PRODUCTION DATA documents contain information current as of publication date. Products conform to specifications per the terms of Texas Instruments standard warranty. Production processing does not necessarily include testing of all parameters.



POST OFFICE BOX 655012 • DALLAS, TEXAS 75266

SN54109, SN74109
DUAL J-K POSITIVE-EDGE-TRIGGERED FLIP-FLOPS WITH PRESET AND CLEAR

logic diagram (positive logic)

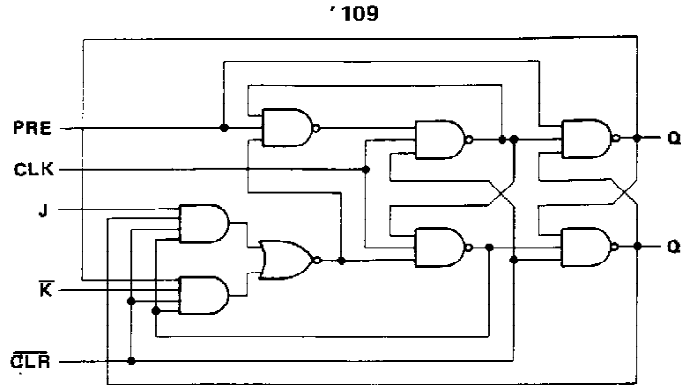

schematics of inputs and outputs

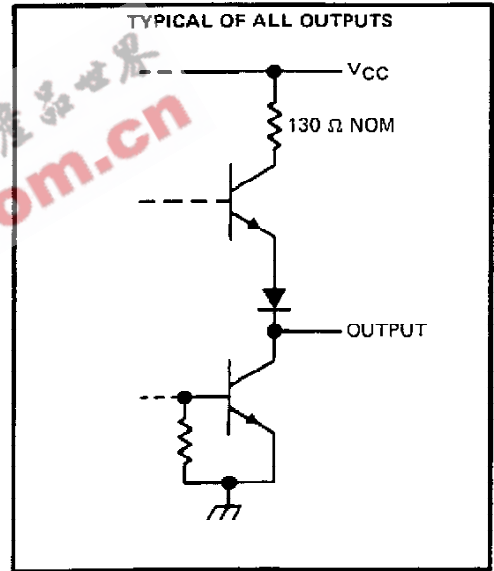
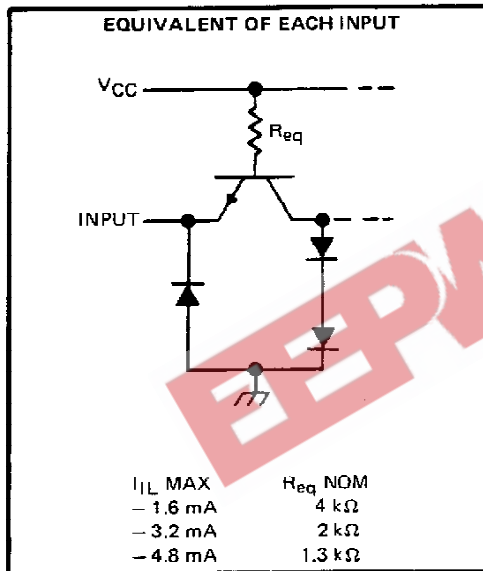

**SN54109, SN54LS109A,
SN74109, SN74LS109A**

DUAL J-K POSITIVE-EDGE-TRIGGERED FLIP-FLOPS WITH PRESET AND CLEAR

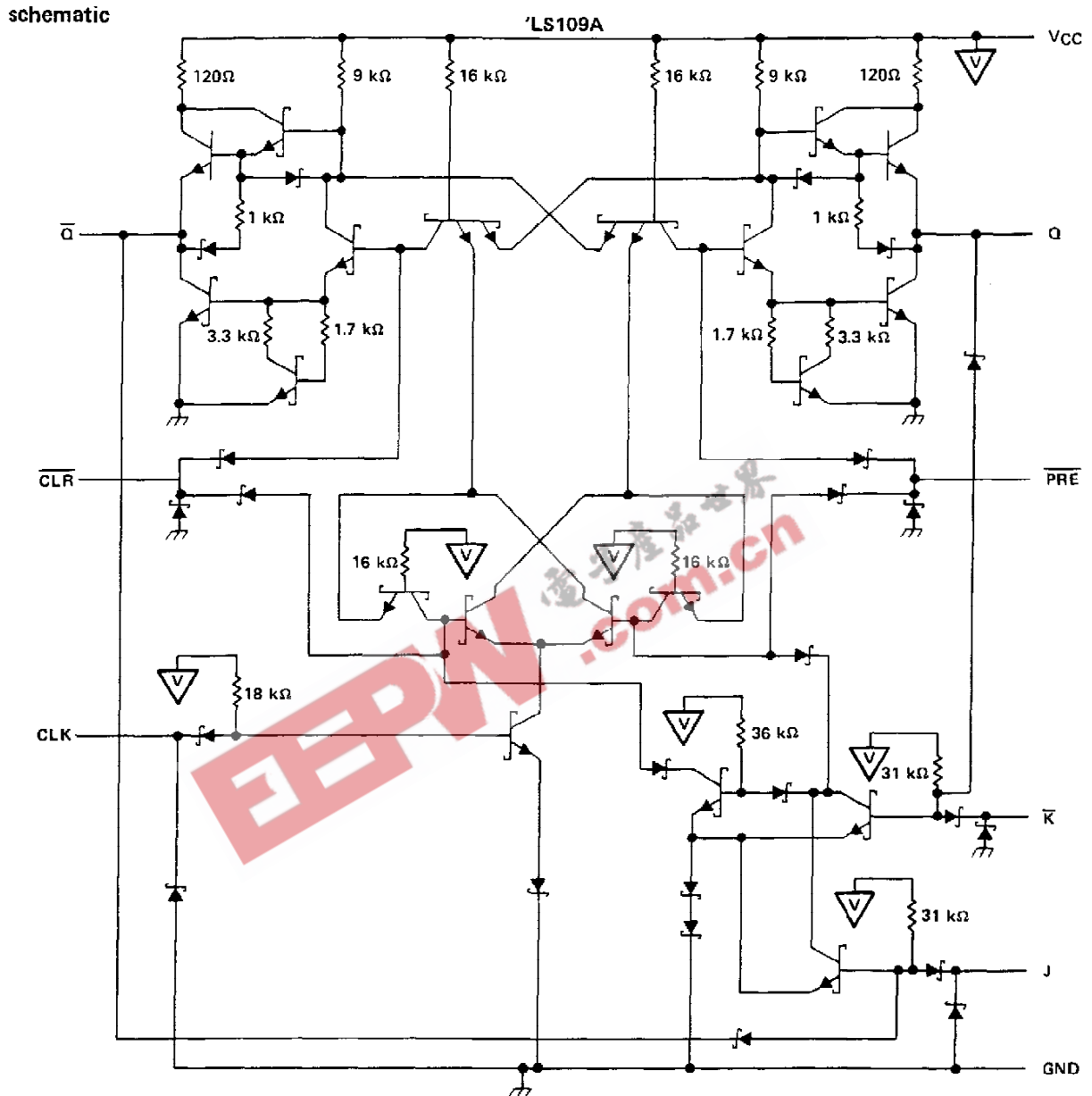

absolute maximum ratings over operating free-air temperature range (unless otherwise noted)

Supply voltage, V_{CC} (see Note 1)	7 V
Input voltage: '109	5.5 V
'LS109A	7 V
Operating free-air temperature range: SN54'	-55°C to 125°C
SN74'	0°C to 70°C
Storage temperature range	-65°C to 150°C

NOTE 1: Voltage values are with respect to network ground terminal.

SN54109, SN74109

DUAL J-K POSITIVE-EDGE-TRIGGERED FLIP-FLOPS WITH PRESET AND CLEAR

recommended operating conditions

	SN54109			SN74109			UNIT
	MIN	NOM	MAX	MIN	NOM	MAX	
V _{CC} Supply voltage	4.5	5	5.5	4.75	5	5.25	V
V _{IH} High-level input voltage	2			2			V
V _{IL} Low-level input voltage	0.8			0.8			V
I _{OH} High-level output current	-0.8			-0.8			mA
I _{OL} Low-level output current	16			16			mA
t _w Pulse duration	CLK high or low		20	20		ns	
	PRE or CLR low		20	20			
t _{su} Input setup time before CLK †	10			10			ns
t _h Input hold time-data after CLK †	6			6			ns
T _A Operating free-air temperature	-55	125		0	70		°C

electrical characteristics over recommended operating free-air temperature range (unless otherwise noted)

PARAMETER	TEST CONDITIONS†	SN54109		SN74109		UNIT
		MIN	TYP‡	MAX	MIN	
V _{IK}	V _{CC} = MIN, I _I = -12 mA			-1.5		V
V _{OH}	V _{CC} = MIN, V _{IH} = 2 V, V _{IL} = 0.8 V, I _{OH} = -0.8 mA	2.4	3.4	2.4	3.4	V
V _{OL}	V _{CC} = MIN, V _{IH} = 2 V, V _{IL} = 0.8 V, I _{OL} = 16 mA	0.2	0.4	0.2	0.4	V
I _I	V _{CC} = MAX, V _I = 5.5 V		1		1	mA
I _{IH}	J or K		40		40	μA
	CLR	V _{CC} = MAX, V _I = 2.4 V	160		160	
	PRE or CLK		80		80	
I _{IL}	J or K	V _{CC} = MAX, V _I = 0.4 V	-1.6		-1.6	mA
	CLR †		-4.8		-4.8	
	PRE †		-3.2		-3.2	
	CLK		-3.2		-3.2	
I _{OS} ‡	V _{CC} = MAX	-30	-85	-30	-85	mA
I _{CC} #	V _{CC} = MAX, See Note 2	9	15	9	15	mA

† For conditions shown as MIN or MAX, use the appropriate value specified under recommended operating conditions.

‡ All typical values are at V_{CC} = 5 V, T_A = 25°C.

§ Not more than one output should be shorted at a time.

† Clear is tested with preset high and preset is tested with clear high.

Average per flip-flop.

NOTE 2: With all outputs open, I_{CC} is measured with the Q and \bar{Q} outputs high in turn. At the time of measurement, the clock input is grounded.

switching characteristics, V_{CC} = 5 V, T_A = 25°C (see note 3)

PARAMETER	FROM (INPUT)	TO (OUTPUT)	TEST CONDITIONS	MIN	TYP	MAX	UNIT
f _{max}				25	33		MHz
t _{PLH}	PRE	Q	R _L = 400 Ω, C _L = 15 pF	10	15		ns
t _{PHL}		\bar{Q}		23	35		ns
t _{PLH}	CLR	\bar{Q}		10	15		ns
t _{PHL}		Q		17	25		ns
t _{PLH}	CLK	Q or \bar{Q}		10	16		ns
t _{PHL}				18	28		ns

NOTE 3: Load circuits and voltage waveforms are shown in Section 1.

TEXAS
INSTRUMENTS

POST OFFICE BOX 655012 • DALLAS, TEXAS 75265

SN54LS109A, SN74LS109A DUAL J-K POSITIVE-EDGE-TRIGGERED FLIP-FLOPS WITH PRESET AND CLEAR

recommended operating conditions

		SN54LS109A			SN74LS109A			UNIT
		MIN	NOM	MAX	MIN	NOM	MAX	
V_{CC}	Supply voltage	4.5	5	5.5	4.75	5	5.25	V
V_{IH}	High-level input voltage	2			2			V
V_{IL}	Low-level input voltage			0.7			0.8	V
I_{OH}	High-level output current			-0.4			-0.4	mA
I_{OL}	Low-level output current			4			8	mA
f_{clock}	Clock frequency	0		25	0		25	MHz
t_w	Pulse duration			25			25	ns
			CLK high	25			25	
t_{su}	Setup time before CLK †			25			25	ns
			PRE or CLR low	25			25	
t_{su}	Setup time before CLK †			35			35	ns
			High-level data	35			35	
t_{su}	Setup time before CLK †			25			25	ns
			Low-level data	25			25	
t_h	Hold time-data after CLK †	5			5			ns
T_A	Operating free-air temperature	-55		125	0		70	°C

electrical characteristics over recommended operating free-air temperature range (unless otherwise noted)

PARAMETER	TEST CONDITIONS†	SN54LS109A		SN74LS109A		UNIT		
		MIN	TYP‡	MAX	MIN		TYP‡	MAX
V_{IK}	$V_{CC} = \text{MIN}$, $I_I = -18 \text{ mA}$			-1.5		-1.5	V	
V_{OH}	$V_{CC} = \text{MIN}$, $I_{OH} = -0.4 \text{ mA}$ $V_{IH} = 2 \text{ V}$, $V_{IL} = \text{MAX}$	2.5	3.4		2.7	3.4	V	
V_{OL}	$V_{CC} = \text{MIN}$, $I_{OL} = 4 \text{ mA}$ $V_{IL} = \text{MAX}$, $V_{IH} = 2 \text{ V}$	0.25	0.4		0.25	0.4	V	
	$V_{CC} = \text{MIN}$, $I_{OL} = 8 \text{ mA}$ $V_{IL} = \text{MAX}$, $V_{IH} = 2 \text{ V}$				0.35	0.5		
I_I	J, K or CLK CLR or PRE			0.1		0.1	mA	
				0.2		0.2		
I_{IH}	J, K or CLK CLR or PRE			20		20	µA	
				40		40		
I_{IL}	J, K or CLK CLR or PRE			-0.4		-0.4	mA	
				-0.8		-0.8		
$I_{OS}§$	$V_{CC} = \text{MAX}$, See Note 4	-20		-100	-20		-100	mA
I_{CC} (Total)	$V_{CC} = \text{MAX}$, See Note 2		4	8		4	8	mA

† For conditions shown as MIN or MAX, use the appropriate value specified under recommended operating conditions.

‡ All typical values are at $V_{CC} = 5 \text{ V}$, $T_A = 25^\circ \text{C}$.

§ Not more than one output should be shorted at a time, and the duration of the short circuit should not exceed one second.

NOTE 2: With all outputs open, I_{CC} is measured with the Q and \bar{Q} outputs high in turn. At the time of measurement, the clock input is grounded.

NOTE 4: For certain devices where state commutation can be caused by shorting an output to ground, an equivalent test may be performed with $V_D = 2.25 \text{ V}$ and 2.125 V for the 54 family and the 74 family, respectively with the minimum and maximum limits reduced to one half of their stated values.

switching characteristics, $V_{CC} = 5 \text{ V}$, $T_A = 25^\circ \text{C}$ (see note 3)

PARAMETER	FROM (INPUT)	TO (OUTPUT)	TEST CONDITIONS	MIN	TYP	MAX	UNIT
f_{max}				25	33		MHz
t_{PLH}	CLR, PRE	Q or \bar{Q}	$R_L = 2 \text{ k}\Omega$, $C_L = 15 \text{ pF}$		13	25	ns
t_{PHL}	or CLK				25	40	ns

NOTE 3: Load circuits and voltage waveforms are shown in Section 1.

**TEXAS
INSTRUMENTS**

POST OFFICE BOX 655012 • DALLAS, TEXAS 75265

IMPORTANT NOTICE

Texas Instruments (TI) reserves the right to make changes to its products or to discontinue any semiconductor product or service without notice, and advises its customers to obtain the latest version of relevant information to verify, before placing orders, that the information being relied on is current.

TI warrants performance of its semiconductor products and related software to the specifications applicable at the time of sale in accordance with TI's standard warranty. Testing and other quality control techniques are utilized to the extent TI deems necessary to support this warranty. Specific testing of all parameters of each device is not necessarily performed, except those mandated by government requirements.

Certain applications using semiconductor products may involve potential risks of death, personal injury, or severe property or environmental damage ("Critical Applications").

TI SEMICONDUCTOR PRODUCTS ARE NOT DESIGNED, INTENDED, AUTHORIZED, OR WARRANTED TO BE SUITABLE FOR USE IN LIFE-SUPPORT APPLICATIONS, DEVICES OR SYSTEMS OR OTHER CRITICAL APPLICATIONS.

Inclusion of TI products in such applications is understood to be fully at the risk of the customer. Use of TI products in such applications requires the written approval of an appropriate TI officer. Questions concerning potential risk applications should be directed to TI through a local SC sales office.

In order to minimize risks associated with the customer's applications, adequate design and operating safeguards should be provided by the customer to minimize inherent or procedural hazards.

TI assumes no liability for applications assistance, customer product design, software performance, or infringement of patents or services described herein. Nor does TI warrant or represent that any license, either express or implied, is granted under any patent right, copyright, mask work right, or other intellectual property right of TI covering or relating to any combination, machine, or process in which such semiconductor products or services might be or are used.

IMPORTANT NOTICE

Texas Instruments and its subsidiaries (TI) reserve the right to make changes to their products or to discontinue any product or service without notice, and advise customers to obtain the latest version of relevant information to verify, before placing orders, that information being relied on is current and complete. All products are sold subject to the terms and conditions of sale supplied at the time of order acknowledgement, including those pertaining to warranty, patent infringement, and limitation of liability.

TI warrants performance of its semiconductor products to the specifications applicable at the time of sale in accordance with TI's standard warranty. Testing and other quality control techniques are utilized to the extent TI deems necessary to support this warranty. Specific testing of all parameters of each device is not necessarily performed, except those mandated by government requirements.

CERTAIN APPLICATIONS USING SEMICONDUCTOR PRODUCTS MAY INVOLVE POTENTIAL RISKS OF DEATH, PERSONAL INJURY, OR SEVERE PROPERTY OR ENVIRONMENTAL DAMAGE ("CRITICAL APPLICATIONS"). TI SEMICONDUCTOR PRODUCTS ARE NOT DESIGNED, AUTHORIZED, OR WARRANTED TO BE SUITABLE FOR USE IN LIFE-SUPPORT DEVICES OR SYSTEMS OR OTHER CRITICAL APPLICATIONS. INCLUSION OF TI PRODUCTS IN SUCH APPLICATIONS IS UNDERSTOOD TO BE FULLY AT THE CUSTOMER'S RISK.

In order to minimize risks associated with the customer's applications, adequate design and operating safeguards must be provided by the customer to minimize inherent or procedural hazards.

TI assumes no liability for applications assistance or customer product design. TI does not warrant or represent that any license, either express or implied, is granted under any patent right, copyright, mask work right, or other intellectual property right of TI covering or relating to any combination, machine, or process in which such semiconductor products or services might be or are used. TI's publication of information regarding any third party's products or services does not constitute TI's approval, warranty or endorsement thereof.