

SN54276, SN74276 QUADRUPLE J-K FLIP-FLOPS

SDLS091

OCTOBER 1976 — REVISED MARCH 1988

- Four J-K Flip-Flops in a Single Package . . . Can Reduce FF Package Count by 50%
- Separate Negative-Edge-Triggered Clocks with Hysteresis . . . Typically 200 mV
- Typical Clock Input Frequency . . . 50 MHz
- Fully Buffered Outputs

description

These quadruple TTL J-K flip-flops incorporate a number of third-generation IC features that can simplify system design and reduce flip-flop package count by up to 50%. They feature hysteresis at each clock input, fully buffered outputs, and direct clear capability, and are presettable through a buffer that also features an input hysteresis loop. The negative-edge-triggering clocks are directly compatible with earlier Series 54/74 single and dual pulse-triggered flip-flops. These circuits can be used to emulate D- or T-type flip-flops by hard-wiring the inputs, or to implement asynchronous sequential functions.

The SN54276 is characterized for operation over the full military temperature range of -55°C to 125°C ; the SN74276 is characterized for operation from 0°C to 70°C .

FUNCTION TABLE (EACH FLIP-FLOP)

COMMON INPUTS		INPUTS			OUTPUT
$\overline{\text{PRE}}$	$\overline{\text{CLR}}$	CLK	J	$\overline{\text{K}}$	Q
L	H	X	X	X	H
H	L	X	X	X	L
L	L	X	X	X	H^{\dagger}
H	H	J	L	H	Q_0
H	H	J	H	H	H
H	H	J	L	L	L
H	H	J	H	L	TOGGLE
H	H	H	X	X	Q_0

[†] This configuration is nonstable; that is, it may not persist when preset and clear return to their inactive (high) level.

SN54276 . . . J PACKAGE
SN74276 . . . N PACKAGE
(TOP VIEW)

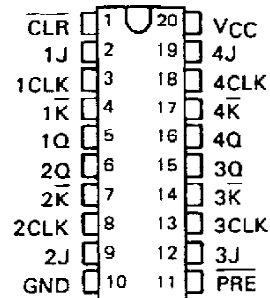

logic symbol[‡]

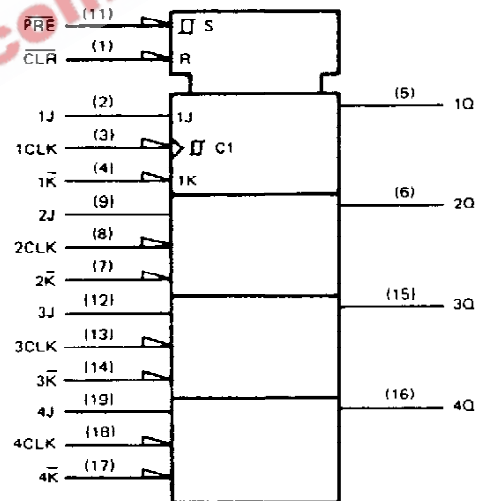

[‡] This symbol is in accordance with ANSI/IEEE Std 91-1984 and IEC Publication 617-12.

PRODUCTION DATA documents contain information current as of publication date. Products conform to specifications per the terms of Texas Instruments standard warranty. Production processing does not necessarily include testing of all parameters.

TEXAS
INSTRUMENTS

POST OFFICE BOX 655012 • DALLAS, TEXAS 75265

SN54276, SN74276 QUADRUPLE J-K FLIP-FLOPS

schematics of inputs and outputs

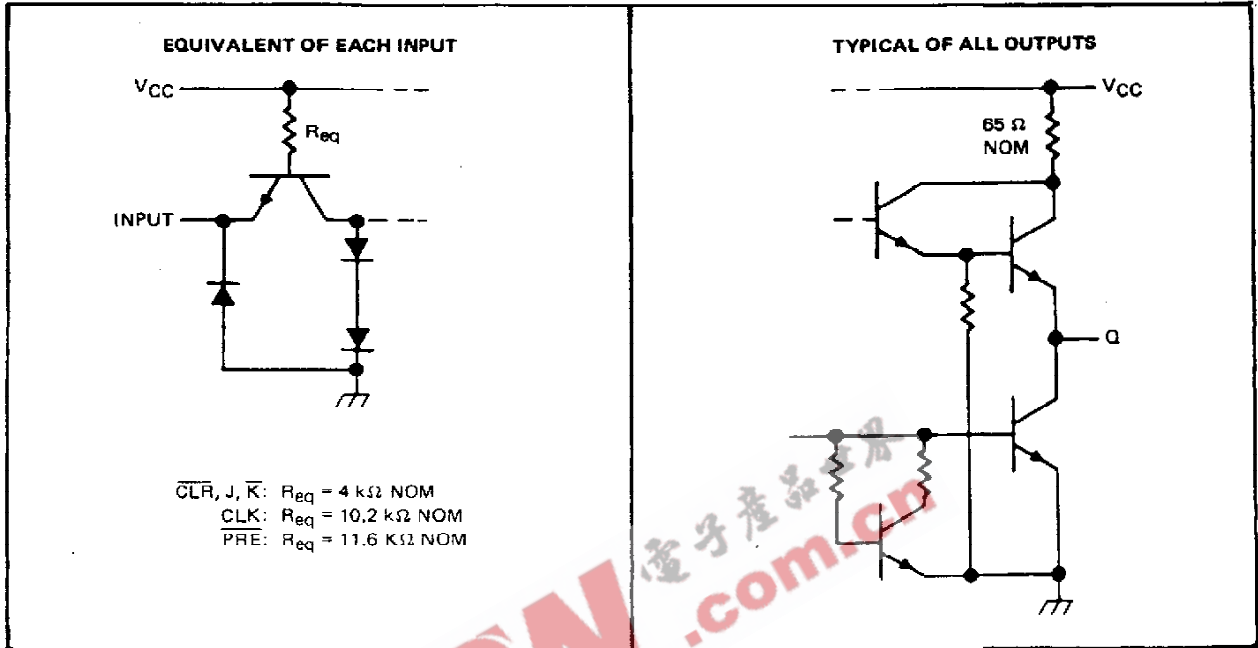

absolute maximum ratings over operating free-air temperature range (unless otherwise noted)

Supply voltage, VCC (see Note 1)	7 V
Input voltage	5.5 V
Operating free-air temperature range: SN54276	-55°C to 125°C
SN74276	0°C to 70°C
Storage temperature range	-65°C to 150°C

NOTE 1: Voltage values are with respect to network ground terminal.

SN54276, SN74276 QUADRUPLE J-K FLIP-FLOPS

recommended operating conditions

		SN54276			SN74276			UNIT
		MIN	NOM	MAX	MIN	NOM	MAX	
Supply voltage, V_{CC}		4.5	5	5.5	4.75	5	5.25	V
High-level output current, I_{OH}		-800			-800			μ A
Low-level output current, I_{OL}		16			16			mA
Clock frequency		0		35	0		35	MHz
Pulse width, t_w	Clock high	13.5			13.5			ns
	Clock low	15			15			
	Preset or clear low	12			12			
Setup time, t_{SU}	J, K inputs	3↓			3↓			ns
	Clear and preset inactive state	10↓			10↓			
Input hold time, t_H		10↓			10↓			ns
Operating free-air temperature, T_A		-55		125	0		70	$^{\circ}$ C

↓ The arrow indicates that the falling edge of the clock pulse is used for reference.

electrical characteristics over recommended operating free-air temperature range (unless otherwise noted)

PARAMETER		TEST CONDITIONS†	MIN	TYP‡	MAX	UNIT
V_{IH}	High-level input voltage		2			V
V_{IL}	Low-level input voltage				0.8	V
V_{IK}	Input clamp voltage	$V_{CC} = \text{MIN}$, $I_I = -12 \text{ mA}$			-1.5	V
V_{OH}	High-level output voltage	$V_{CC} = \text{MIN}$, $V_{IH} = 2 \text{ V}$, $V_{IL} = 0.8 \text{ V}$, $I_{OH} = -800 \mu\text{A}$	2.4	3.4		V
V_{OL}	Low-level output voltage	$V_{CC} = \text{MIN}$, $V_{IH} = 2 \text{ V}$, $V_{IL} = 0.8 \text{ V}$, $I_{OL} = 16 \text{ mA}$		0.2	0.4	V
I_I	Input current at maximum input voltage	$V_{CC} = \text{MAX}$, $V_I = 5.5 \text{ V}$			1	mA
I_{IH}	High-level input current	$V_{CC} = \text{MAX}$, $V_I = 2.4 \text{ V}$			40	μ A
I_{IL}	Low-level input current	$V_{CC} = \text{MAX}$, $V_I = 0.4 \text{ V}$			-1.6	mA
I_{OS}	Short-circuit output current§	$V_{CC} = \text{MAX}$	-30		-85	mA
I_{CC}	Supply current	$V_{CC} = \text{MAX}$		60	81	mA

† For conditions shown as MIN or MAX, use the appropriate value specified under recommended operating conditions.

‡ All typical values are at $V_{CC} = 5 \text{ V}$, $T_A = 25^{\circ}\text{C}$.

§ Not more than one output should be shorted at a time.

switching characteristics, $V_{CC} = 5 \text{ V}$, $T_A = 25^{\circ}\text{C}$

PARAMETER		TEST CONDITIONS	MIN	TYP	MAX	UNIT
f_{max}	Maximum clock frequency	$C_L = 15 \text{ pF}$, $R_L = 400 \Omega$, See Note 2	35	50		MHz
t_{PLH}	Propagation delay time, low-to-high-level output from preset		15	25		ns
t_{PHL}	Propagation delay time, high-to-low-level output from clear		18	30		ns
t_{PLH}	Propagation delay time, low-to-high level output from clock		17	30		ns
t_{PHL}	Propagation delay time, high-to-low level output from clock		20	30		ns

NOTE 2: Load circuits and voltage waveforms are shown in Section 1.

TEXAS
INSTRUMENTS

POST OFFICE BOX 65512 • DALLAS, TEXAS 75265

IMPORTANT NOTICE

Texas Instruments (TI) reserves the right to make changes to its products or to discontinue any semiconductor product or service without notice, and advises its customers to obtain the latest version of relevant information to verify, before placing orders, that the information being relied on is current.

TI warrants performance of its semiconductor products and related software to the specifications applicable at the time of sale in accordance with TI's standard warranty. Testing and other quality control techniques are utilized to the extent TI deems necessary to support this warranty. Specific testing of all parameters of each device is not necessarily performed, except those mandated by government requirements.

Certain applications using semiconductor products may involve potential risks of death, personal injury, or severe property or environmental damage ("Critical Applications").

TI SEMICONDUCTOR PRODUCTS ARE NOT DESIGNED, INTENDED, AUTHORIZED, OR WARRANTED TO BE SUITABLE FOR USE IN LIFE-SUPPORT APPLICATIONS, DEVICES OR SYSTEMS OR OTHER CRITICAL APPLICATIONS.

Inclusion of TI products in such applications is understood to be fully at the risk of the customer. Use of TI products in such applications requires the written approval of an appropriate TI officer. Questions concerning potential risk applications should be directed to TI through a local SC sales office.

In order to minimize risks associated with the customer's applications, adequate design and operating safeguards should be provided by the customer to minimize inherent or procedural hazards.

TI assumes no liability for applications assistance, customer product design, software performance, or infringement of patents or services described herein. Nor does TI warrant or represent that any license, either express or implied, is granted under any patent right, copyright, mask work right, or other intellectual property right of TI covering or relating to any combination, machine, or process in which such semiconductor products or services might be or are used.

IMPORTANT NOTICE

Texas Instruments and its subsidiaries (TI) reserve the right to make changes to their products or to discontinue any product or service without notice, and advise customers to obtain the latest version of relevant information to verify, before placing orders, that information being relied on is current and complete. All products are sold subject to the terms and conditions of sale supplied at the time of order acknowledgement, including those pertaining to warranty, patent infringement, and limitation of liability.

TI warrants performance of its semiconductor products to the specifications applicable at the time of sale in accordance with TI's standard warranty. Testing and other quality control techniques are utilized to the extent TI deems necessary to support this warranty. Specific testing of all parameters of each device is not necessarily performed, except those mandated by government requirements.

CERTAIN APPLICATIONS USING SEMICONDUCTOR PRODUCTS MAY INVOLVE POTENTIAL RISKS OF DEATH, PERSONAL INJURY, OR SEVERE PROPERTY OR ENVIRONMENTAL DAMAGE ("CRITICAL APPLICATIONS"). TI SEMICONDUCTOR PRODUCTS ARE NOT DESIGNED, AUTHORIZED, OR WARRANTED TO BE SUITABLE FOR USE IN LIFE-SUPPORT DEVICES OR SYSTEMS OR OTHER CRITICAL APPLICATIONS. INCLUSION OF TI PRODUCTS IN SUCH APPLICATIONS IS UNDERSTOOD TO BE FULLY AT THE CUSTOMER'S RISK.

In order to minimize risks associated with the customer's applications, adequate design and operating safeguards must be provided by the customer to minimize inherent or procedural hazards.

TI assumes no liability for applications assistance or customer product design. TI does not warrant or represent that any license, either express or implied, is granted under any patent right, copyright, mask work right, or other intellectual property right of TI covering or relating to any combination, machine, or process in which such semiconductor products or services might be or are used. TI's publication of information regarding any third party's products or services does not constitute TI's approval, warranty or endorsement thereof.