

Document Title

32Kx8 bit Low Power CMOS Static RAM

Revision History

<u>Revision No.</u>	<u>History</u>	<u>Draft Data</u>	<u>Remark</u>
0.0	Initial draft	October 09, 2002	Preliminary
0.1	revised - errata : corrected 28-SOP-525 to 28-SOP-450 in package type	November 08, 2002	Preliminary
0.2	revised - Added commercial product.	March 27, 2003	Preliminary
1.0	Finalized - Changed Icc from 3mA to 2mA - Changed Icc2 from 25mA to 20mA - Changed Isb from 3mA to 0.4mA - Changed Isb1 for K6X0808T1D-F from 10μA to 6μA - Changed Isb1 for K6X0808T1D-F from 20μA to 10μA - Changed Idr for K6X0808T1D-F 10μA to 6μA - Changed Idr for K6X0808T1D-Q 20μA to 10μA - Errata correction	December 16, 2003	Final

EEPW.com.cn 电子产品世界

The attached datasheets are provided by SAMSUNG Electronics. SAMSUNG Electronics CO., LTD. reserves the right to change the specifications and products. SAMSUNG Electronics will answer to your questions. If you have any questions, please contact the SAMSUNG branch offices.

K6X0808T1D Family

CMOS SRAM

32Kx8 bit Super Low Power and Low Voltage full CMOS Static RAM

FEATURES

- Process Technology: Full CMOS28-
- Organization: 32K x 8
- Power Supply Voltage: 2.7~3.6V
- Low Data Retention Voltage: 1.5V(Min)
- Three state outputs
- Package Type: 28-SOP-450, 28-TSOP1-0813.4F/R

GENERAL DESCRIPTION

The K6X0808T1D families are fabricated by SAMSUNG's advanced CMOS process technology. The families support various operating temperature ranges and have various package types for user flexibility of system design. The families also support low data retention voltage for battery back-up operation with low data retention current.

PRODUCT FAMILY

Product Family	Operating Temperature	Vcc Range	Speed	Power Dissipation		PKG Type
				Standby (I _{SB1} , Max)	Operating (I _{CC2} , Max)	
K6X0808T1D-B	Industrial(0~70°C)	2.7~3.6V	70 ¹⁾ /85ns	6μA	25mA	28-SOP-450, 28-TSOP1-0813.4F/R
K6X0808T1D-F	Industrial(-40~85°C)					
K6X0808T1D-Q	Automotive(-40~125°C)			10μA	28-SOP-450, 28-TSOP1-0813.4F	

1. The parameters are tested with 30pF test load

PIN DESCRIPTION

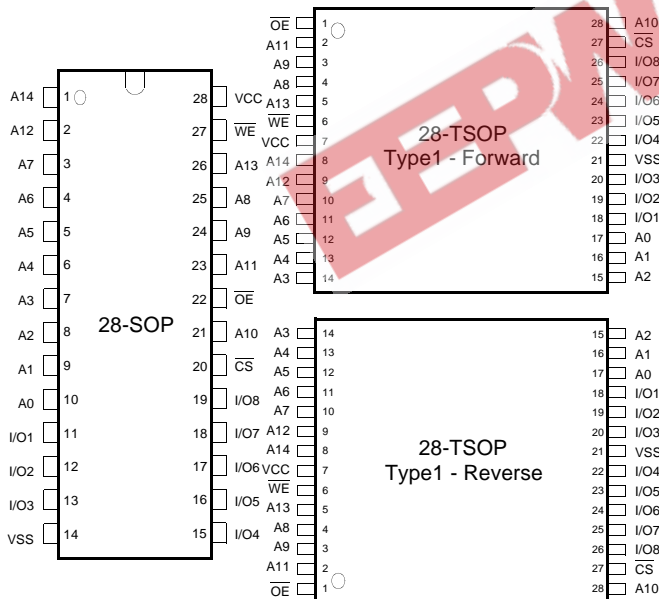

Pin Name	Function	Pin Name	Function
A ₀ ~A ₁₄	Address Inputs	I/O ₁ ~I/O ₈	Data Inputs/Outputs
\overline{WE}	Write Enable Input	Vcc	Power
\overline{CS}	Chip Select Input	Vss	Ground
\overline{OE}	Output Enable Input	NC	No connect

FUNCTIONAL BLOCK DIAGRAM

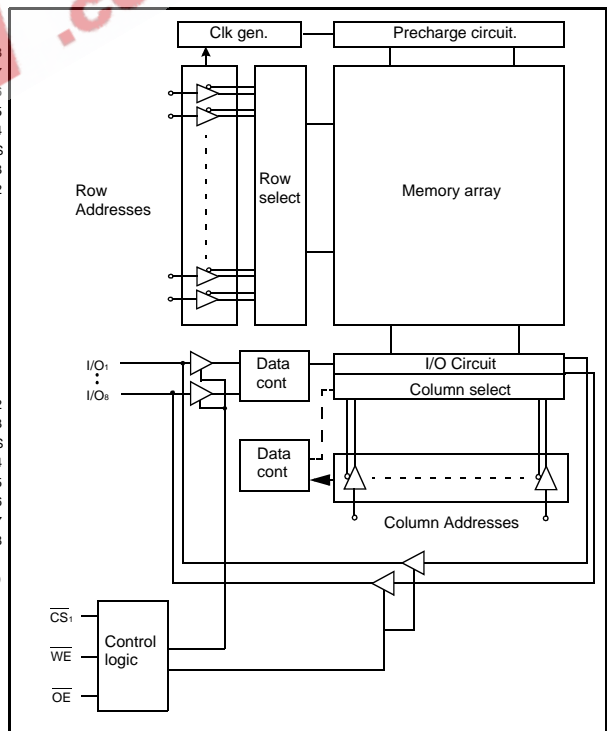

SAMSUNG ELECTRONICS CO., LTD. reserves the right to change products and specifications without notice.

PRODUCT LIST

Commercial Temp. Products(0~70°C)		Industrial Temp. Products(-40~85°C)		Automotive Temp. Products(-40~125°C)	
Part Name	Function	Part Name	Function	Part Name	Function
K6X0808T1D-GB70	28-SOP, 70ns, LL	K6X0808T1D-GF70	28-SOP, 70ns, LL	K6X0808T1D-GQ70	28-SOP, 70ns, L
K6X0808T1D-GB85	28-SOP, 85ns, LL	K6X0808T1D-GF85	28-SOP, 85ns, LL	K6X0808T1D-GQ85	28-SOP, 85ns, L
K6X0808T1D-YB70	28-sTSOP-F, 70ns, LL	K6X0808T1D-YF70	28-sTSOP-F, 70ns, LL	K6X0808T1D-YQ70	28-sTSOP-F, 70ns, L
K6X0808T1D-YB85	28-sTSOP-F, 85ns, LL	K6X0808T1D-YF85	28-sTSOP-F, 85ns, LL	K6X0808T1D-YQ85	28-sTSOP-F, 85ns, L
K6X0808T1D-NB70	28-sTSOP-R, 70ns, LL	K6X0808T1D-NF70	28-sTSOP-R, 70ns, LL		
K6X0808T1D-NB85	28-sTSOP-R, 85ns, LL	K6X0808T1D-NF85	28-sTSOP-R, 85ns, LL		

FUNCTIONAL DESCRIPTION

\overline{CS}	\overline{OE}	\overline{WE}	I/O	Mode	Power
H	X ¹⁾	X ¹⁾	High-Z	Deselected	Standby
L	H	H	High-Z	Output Disabled	Active
L	L	H	Dout	Read	Active
L	X ¹⁾	L	Din	Write	Active

1. X means don't care (Must be in high or low states)

ABSOLUTE MAXIMUM RATINGS¹⁾

Item	Symbol	Ratings	Unit	Remark
Voltage on any pin relative to Vss	V _{IN} , V _{OUT}	-0.2 to V _{CC} +0.3V(Max. 3.9V)	V	-
Voltage on Vcc supply relative to Vss	V _{CC}	-0.2 to 3.9	V	-
Power Dissipation	P _D	1.0	W	-
Storage temperature	T _{STG}	-65 to 150	°C	-
Operating Temperature	T _A	-40 to 85	°C	K6X0808T1D-F
		-40 to 125	°C	K6X0808T1D-Q

1. Stresses greater than those listed under "Absolute Maximum Ratings" may cause permanent damage to the device. Functional operation should be restricted to recommended operating condition. Exposure to absolute maximum rating conditions for extended periods may affect reliability.

RECOMMENDED DC OPERATING CONDITIONS¹⁾

Item	Symbol	Min	Typ	Max	Unit
Supply voltage	V _{CC}	2.7	3.0/3.3	3.6	V
Ground	V _{SS}	0	0	0	V
Input high voltage	V _{IH}	2.2	-	V _{CC} +0.2 ²⁾	V
Input low voltage	V _{IL}	-0.2 ³⁾	-	0.6	V

Note:

1. Industrial Product: T_A=-40 to 85°C, Otherwise specified
Automotive Product: T_A=-40 to 125°C, Otherwise specified
2. Overshoot: V_{CC}+3.0V in case of pulse width≤30ns.
3. Undershoot: -3.0V in case of pulse width≤30ns.
4. Overshoot and undershoot are sampled, not 100% tested.

CAPACITANCE¹⁾ (f=1MHz, T_A=25°C)

Item	Symbol	Test Condition	Min	Max	Unit
Input capacitance	C _{IN}	V _{IN} =0V	-	8	pF
Input/Output capacitance	C _{IO}	V _{IO} =0V	-	10	pF

1. Capacitance is sampled, not 100% tested

DC AND OPERATING CHARACTERISTICS

Item	Symbol	Test Conditions	Min	Typ	Max	Unit	
Input leakage current	I _{LI}	V _{IN} =V _{SS} to V _{CC}	-1	-	1	μA	
Output leakage current	I _{LO}	$\overline{CS}=V_{IH}$ or $\overline{OE}=V_{IH}$ or $\overline{WE}=V_{IL}$, V _{IO} =V _{SS} to V _{CC}	-1	-	1	μA	
Operating power supply current	I _{CC}	I _{IO} =0mA, $\overline{CS}=V_{IL}$, V _{IN} =V _{IH} or V _{IL} , Read	-	-	2	mA	
Average operating current	I _{CC1}	Cycle time=1μs, 100% duty, I _{IO} =0mA, $\overline{CS} \leq 0.2V$, V _{IN} ≤0.2V, V _{IN} ≥V _{CC} -0.2V	-	-	3	mA	
	I _{CC2}	Cycle time=Min, 100% duty, I _{IO} =0mA, $\overline{CS}=V_{IL}$, V _{IN} =V _{IH} or V _{IL}	-	-	20	mA	
Output low voltage	V _{OL}	I _{OL} =2.1mA	-	-	0.4	V	
Output high voltage	V _{OH}	I _{OH} =-1.0mA	2.4	-	-	V	
Standby Current(TTL)	I _{SB}	$\overline{CS}=V_{IH}$, Other inputs=V _{IH} or V _{IL}	-	-	0.3	mA	
Standby Current(CMOS)	I _{SB1}	$\overline{CS} \geq V_{CC}-0.2V$, Other inputs=0-V _{CC}	K6X0808T1D-F	-	-	6	μA
			K6X0808T1D-Q	-	-	10	μA

AC OPERATING CONDITIONS

TEST CONDITIONS (Test Load and Input/Output Reference)

Input pulse level: 0.4 to 2.2V
 Input rising and falling time: 5ns
 Input and output reference voltage: 1.5V
 Output load(see right): $C_L=100\text{pF}+1\text{TTL}$
 $C_L=30\text{pF}+1\text{TTL}$

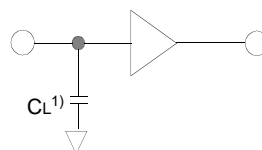

1. Including scope and jig capacitance

AC CHARACTERISTICS (V_{CC}=2.7~3.6V, Industrial product: T_A=-40 to 85°C, Automotive product: T_A=-40 to 125°C)

Parameter List		Symbol	Speed Bins				Units
			70ns		85ns		
			Min	Max	Min	Max	
Read	Read Cycle Time	t _{RC}	70	-	85	-	ns
	Address Access Time	t _{AA}	-	70	-	85	ns
	Chip Select to Output	t _{CO}	-	70	-	85	ns
	Output Enable to Valid Output	t _{OE}	-	35	-	40	ns
	Chip Select to Low-Z Output	t _{LZ}	10	-	10	-	ns
	Output Enable to Low-Z Output	t _{OLZ}	5	-	5	-	ns
	Chip Disable to High-Z Output	t _{HZ}	0	25	0	25	ns
	Output Disable to High-Z Output	t _{OHZ}	0	25	0	25	ns
	Output Hold from Address Change	t _{OH}	10	-	15	-	ns
Write	Write Cycle Time	t _{WC}	70	-	85	-	ns
	Chip Select to End of Write	t _{CW}	60	-	70	-	ns
	Address Set-up Time	t _{AS}	0	-	0	-	ns
	Address Valid to End of Write	t _{AW}	60	-	70	-	ns
	Write Pulse Width	t _{WP}	50	-	60	-	ns
	Write Recovery Time	t _{WR}	0	-	0	-	ns
	Write to Output High-Z	t _{WHZ}	0	25	0	30	ns
	Data to Write Time Overlap	t _{DW}	25	-	35	-	ns
	Data Hold from Write Time	t _{DH}	0	-	0	-	ns
	End Write to Output Low-Z	t _{OW}	5	-	5	-	ns

DATA RETENTION CHARACTERISTICS

Item	Symbol	Test Condition	Min	Typ	Max	Unit	
V _{CC} for data retention	V _{DR}	$\overline{CS}_1 \geq V_{CC}-0.2V$	2.0	-	3.6	V	
Data retention current	I _{DR}	V _{CC} =3.0V, $\overline{CS}_1 \geq V_{CC}-0.2V$	K6X0808T1D-F	-	-	6	μA
			K6X0808T1D-Q	-	-	10	μA
Data retention set-up time	t _{SDR}	See data retention waveform	0	-	-	ms	
Recovery time	t _{RDR}		5	-	-		

TIMING DIAGRAMS

TIMING WAVEFORM OF READ CYCLE(1) (Address Controlled, $\overline{CS}=\overline{OE}=V_{IL}$, $\overline{WE}=V_{IH}$)

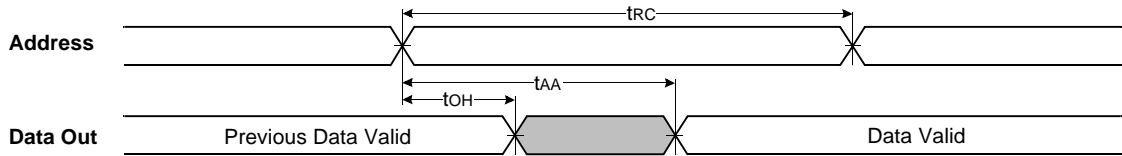

TIMING WAVEFORM OF READ CYCLE(2) ($\overline{WE}=V_{IH}$)

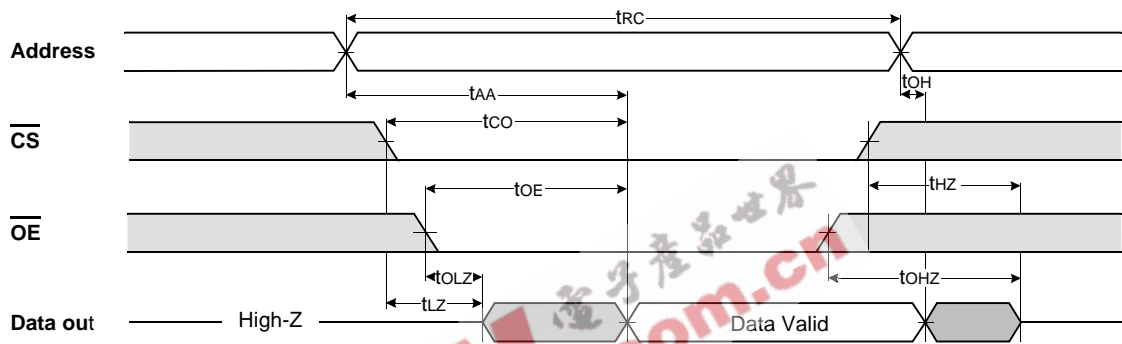

NOTES (READ CYCLE)

1. t_{HZ} and t_{OHZ} are defined as the time at which the outputs achieve the open circuit conditions and are not referenced to output voltage levels.
2. At any given temperature and voltage condition, $t_{HZ}(\text{Max.})$ is less than $t_{LZ}(\text{Min.})$ both for a given device and from device to device interconnection.

TIMING WAVEFORM OF WRITE CYCLE(1) (\overline{WE} Controlled)

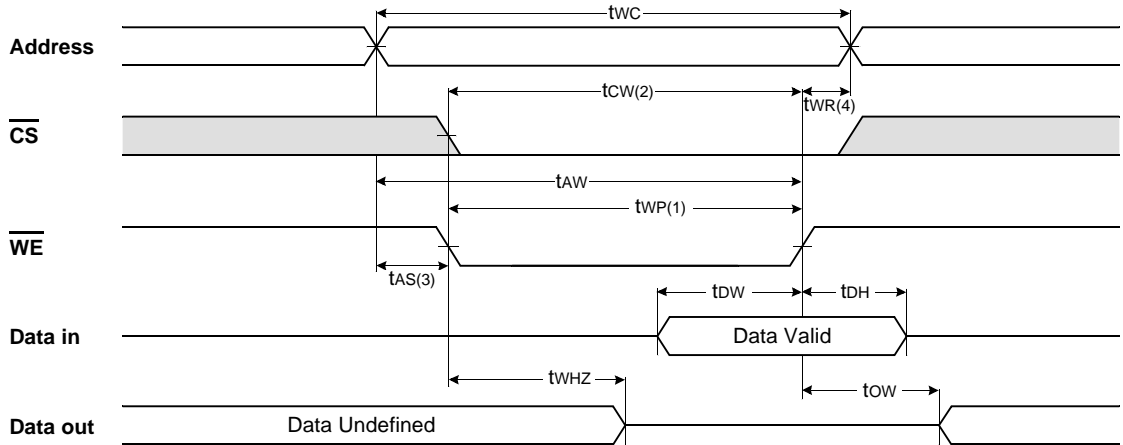

TIMING WAVEFORM OF WRITE CYCLE(2) (\overline{CS} Controlled)

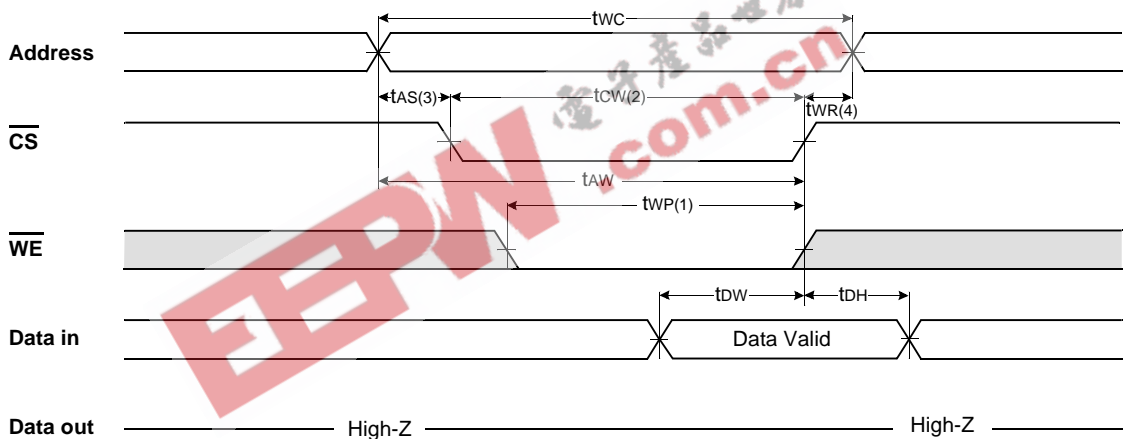

NOTES (WRITE CYCLE)

1. A write occurs during the overlap of a low \overline{CS} and a low \overline{WE} . A write begins at the latest transition among \overline{CS} going Low and \overline{WE} going low : A write end at the earliest transition among \overline{CS} going high and \overline{WE} going high, t_{WP} is measured from the beginning of write to the end of write.
2. t_{CW} is measured from the \overline{CS} going low to the end of write.
3. t_{AS} is measured from the address valid to the beginning of write.
4. t_{WR} is measured from the end of write to the address change. t_{WR} applied in case a write ends as \overline{CS} or \overline{WE} going high.

DATA RETENTION WAVE FORM

\overline{CS} controlled

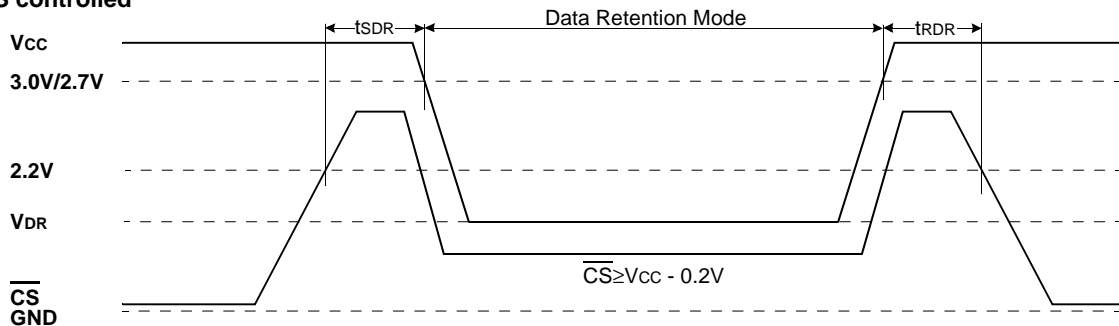

K6X0808T1D Family

CMOS SRAM

PACKAGE DIMENSIONS

Units: millimeter(inch)

28 PIN PLASTIC SMALL OUTLINE PACKAGE(450mil)

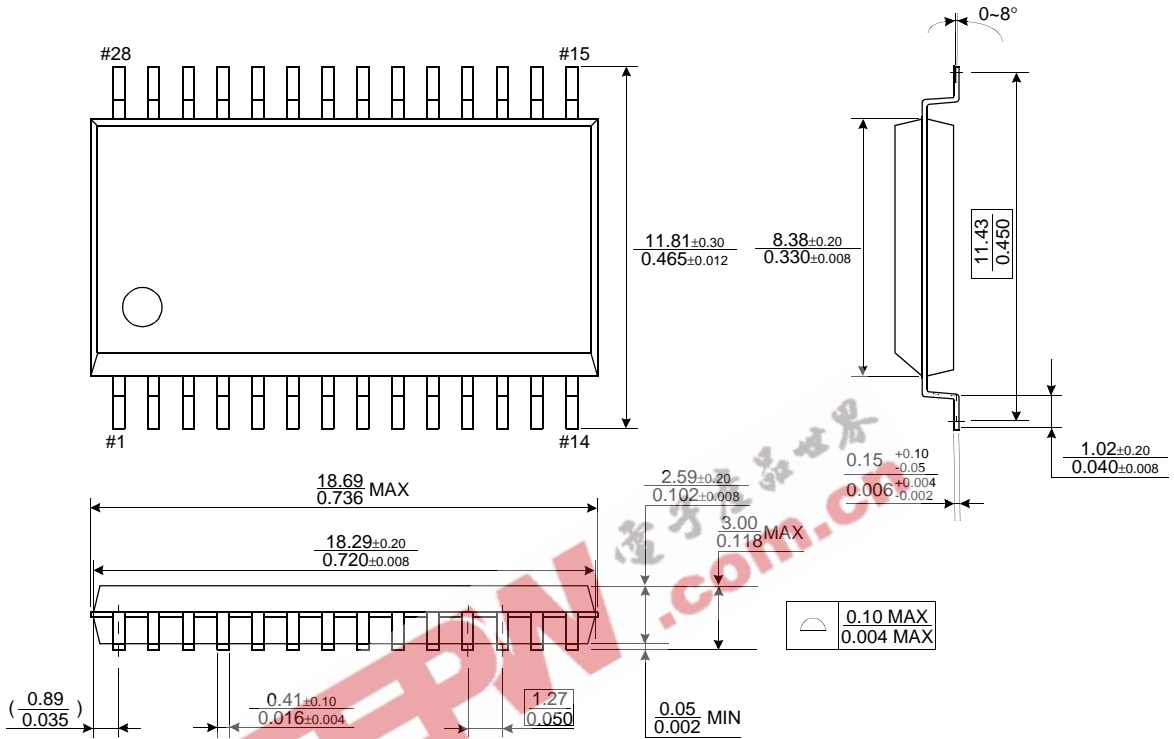

PACKAGE DIMENSIONS

28 PIN THIN SMALL OUTLINE PACKAGE TYPE1 (0813.4F)

Units: millimeter(inch)

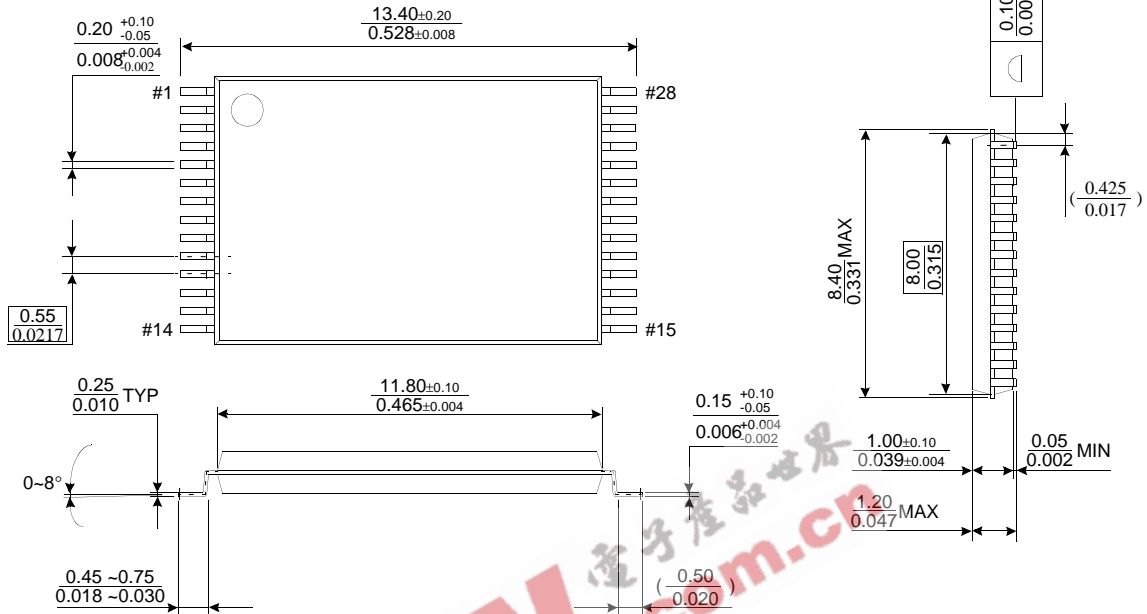

28 PIN THIN SMALL OUTLINE PACKAGE TYPE1 (0813.4R)

