

Document Title

128K x8 bit Low Power CMOS Static RAM

Revision History

<u>Revision No.</u>	<u>History</u>	<u>Draft Date</u>	<u>Remark</u>
0.0	Initial draft	November 22, 1995	Design target
0.1	First revision - Seperate read and write at Icc, Icc1 Icc = Icc1 → Read : 15mA, Write : 35mA	April 15, 1996	Preliminary
1.0	Finalized - Add 70ns speed bin for commercial product and 85ns speed bin for industrial.	September 5, 1996	Final
2.0	Revised - Improved operating current Add typical value. Icc Read : 15mA → 10mA(Remove write current) Icc2 : 90mA → 60mA - Speed bin change Remove 45ns from commercial part Remove 55ns and 100ns from industrial part.	November 5, 1997	Final

EEPW.com.cn
电子產品世界

The attached data sheets are provided by SAMSUNG Electronics. SAMSUNG Electronics CO., LTD. reserve the right to change the specifications and products. SAMSUNG Electronics will answer to your questions about device. If you have any questions, please contact the SAMSUNG branch offices.

128K x8 bit Low Power CMOS Static RAM

FEATURES

- Process Technology: TFT
- Organization: 128K x8
- Power Supply Voltage: 4.5~5.5V
- Low Data Retention Voltage: 2V(Min)
- Three state output and TTL Compatible
- Package Type: 32-DIP-600, 32-SOP-525, 32-TSOP1-0820F/R

GENERAL DESCRIPTION

The K6T1008C2C families are fabricated by SAMSUNG's advanced CMOS process technology. The families support various operating temperature ranges and have various package types for user flexibility of system design. The families also support low data retention voltage for battery back-up operation with low data retention current.

PRODUCT FAMILY

Product Family	Operating Temperature	Vcc Range	Speed	Power Dissipation		PKG Type
				Standby (I _{SB1} , Max)	Operating (I _{CC2} , Max)	
K6T1008C2C-L K6T1008C2C-B	Commercial(0~70°C)	4.5~5.5V	55/70ns	50μA 10μA	60mA	32-DIP, 32-SOP 32-TSOP1-F/R
K6T1008C2C-P K6T1008C2C-F	Industrial(-40~85°C)		70ns	50μA 15μA		

PIN DESCRIPTION

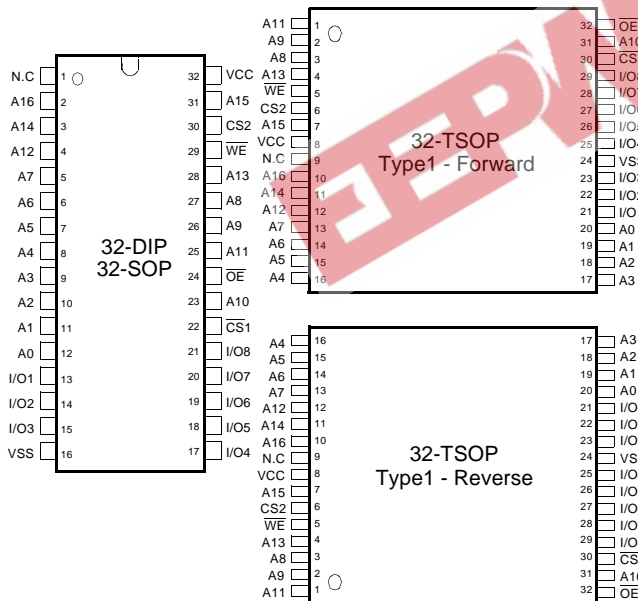

Name	Function	Name	Function
$\overline{CS1}, \overline{CS2}$	Chip Select Inputs	I/O1~I/O8	Data Inputs/Outputs
\overline{OE}	Output Enable	Vcc	Power
\overline{WE}	Write Enable Input	Vss	Ground
A0~A16	Address Inputs	N.C	No Connection

FUNCTIONAL BLOCK DIAGRAM

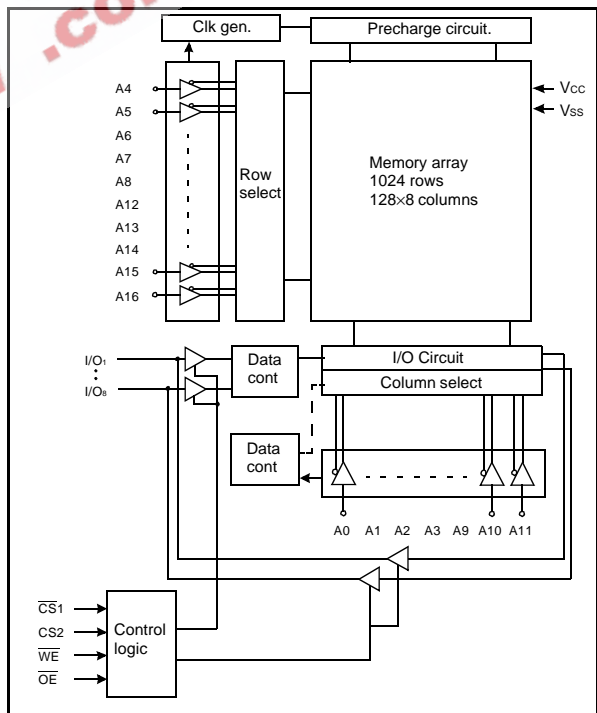

SAMSUNG ELECTRONICS CO., LTD. reserves the right to change products and specifications without notice.

PRODUCT LIST

Commercial Temperature Products(0~70°C)		Industrial Temperature Products(-40~85°C)	
Part Name	Function	Part Name	Function
K6T1008C2C-DL55	32-DIP, 55ns, L-pwr	K6T1008C2C-GP70	32-SOP, 70ns, L-pwr
K6T1008C2C-DL70	32-DIP, 70ns, L-pwr	K6T1008C2C-GF70	32-SOP, 70ns, LL-pwr
K6T1008C2C-DB55	32-DIP, 55ns, LL-pwr	K6T1008C2C-TF70 K6T1008C2C-RF70	32-TSOP1-F, 70ns, LL-pwr 32-TSOP1-R, 70ns, LL-pwr
K6T1008C2C-DB70	32-DIP, 70ns, LL-pwr		
K6T1008C2C-GL55	32-SOP, 55ns, L-pwr		
K6T1008C2C-GL70	32-SOP, 70ns, L-pwr		
K6T1008C2C-GB55	32-SOP, 55ns, LL-pwr		
K6T1008C2C-GB70	32-SOP, 70ns, LL-pwr		
K6T1008C2C-TB55	32-TSOP1-F, 55ns, LL-pwr		
K6T1008C2C-TB70	32-TSOP1-F, 70ns, LL-pwr		
K6T1008C2C-RB55	32-TSOP1-R, 55ns, LL-pwr		
K6T1008C2C-RB70	32-TSOP1-R, 70ns, LL-pwr		

FUNCTIONAL DESCRIPTION

CS ₁	CS ₂	OE	WE	I/O Pin	Mode	Power
H	X ¹⁾	X ¹⁾	X ¹⁾	High-Z	Deselected	Standby
X ¹⁾	L	X ¹⁾	X ¹⁾	High-Z	Deselected	Standby
L	H	H	H	High-Z	Output Disable	Active
L	H	L	H	Dout	Read	Active
L	H	X ¹⁾	L	Din	Write	Active

1. X means don't care(Must be in high or low status.)

ABSOLUTE MAXIMUM RATINGS¹⁾

Item	Symbol	Ratings	Unit	Remark
Voltage on any pin relative to Vss	V _{IN} , V _{OUT}	-0.5 to 7.0	V	-
Voltage on Vcc supply relative to Vss	V _{CC}	-0.5 to 7.0	V	-
Power Dissipation	P _D	1.0	W	-
Storage temperature	T _{STG}	-65 to 150	°C	-
Operating Temperature	T _A	0 to 70	°C	K6T1008C2C-L
		-40 to 85	°C	K6T1008C2C-P
Soldering temperature and time	T _{SOLDER}	260°C, 10sec (Lead Only)	-	-

1. Stresses greater than those listed under "Absolute Maximum Ratings" may cause permanent damage to the device. Functional operation should be restricted to recommended operating condition. Exposure to absolute maximum rating conditions for extended periods may affect reliability.

RECOMMENDED DC OPERATING CONDITIONS¹⁾

Item	Symbol	Min	Typ	Max	Unit
Supply voltage	V _{CC}	4.5	5.0	5.5	V
Ground	V _{SS}	0	0	0	V
Input high voltage	V _{IH}	2.2	-	V _{CC} +0.5 ²⁾	V
Input low voltage	V _{IL}	-0.5 ³⁾	-	0.8	V

Note

- Commercial Product : T_A=0 to 70°C and Industrial Product : T_A=-40 to 85°C, otherwise specified.
- Overshoot : V_{CC}+3.0V for ≤30ns pulse width.
- Undershoot : -3.0V for ≤30ns pulse width.
- Overshoot and undershoot are sampled, not 100% tested.

CAPACITANCE¹⁾ (f=1MHz, T_A=25°C)

Item	Symbol	Test Condition	Min	Max	Unit
Input capacitance	C _{IN}	V _{IN} =0V	-	6	pF
Input/Output capacitance	C _{IO}	V _{IO} =0V	-	8	pF

- Capacitance is sampled not, 100% tested.

DC AND OPERATING CHARACTERISTICS

Item	Symbol	Test Conditions	Min	Typ	Max	Unit	
Input leakage current	I _{LI}	V _{IN} =V _{SS} to V _{CC}	-1	-	1	μA	
Output leakage current	I _{LO}	$\overline{CS}_1=V_{IH}$ or $\overline{CS}_2=V_{IL}$ or $\overline{OE}=V_{IH}$ or $\overline{WE}=V_{IL}$, V _{IO} =V _{SS} to V _{CC}	-1	-	1	μA	
Operating power supply current	I _{CC}	I _{IO} =0mA, $\overline{CS}_1=V_{IL}$, $\overline{CS}_2=V_{IH}$, V _{IN} =V _{IH} or V _{IL} , Read	-	5	10	mA	
Average operating current	I _{CC1}	Cycle time=1μs, 100% duty, I _{IO} =0mA, $\overline{CS}_1 \leq 0.2V$, $\overline{CS}_2 \geq V_{CC}-0.2V$, V _{IN} ≤ 0.2V or V _{IN} ≥ V _{CC} -0.2V	Read	-	2	5	mA
			Write	-	20	35	
	I _{CC2}	Cycle time=Min, 100% duty, I _{IO} =0mA, $\overline{CS}_1=V_{IL}$, $\overline{CS}_2=V_{IH}$, V _{IN} =V _{IL} or V _{IH}	-	45	60	mA	
Output low voltage	V _{OL}	I _{OL} =2.1mA	-	-	0.4	V	
Output high voltage	V _{OH}	I _{OH} =-1.0mA	2.4	-	-	V	
Standby Current(TTL)	I _{SB}	$\overline{CS}_1=V_{IH}$, $\overline{CS}_2=V_{IL}$, Other input=V _{IL} or V _{IH}	-	-	3	mA	
Standby Current (CMOS)	K6T1008C2C-L	$\overline{CS}_1 \geq V_{CC}-0.2V$, $\overline{CS}_2 \geq V_{CC}-0.2V$ or $\overline{CS}_2 \leq 0.2V$ Other input =0~V _{CC}	Low Power	-	1	50	μA
	K6T1008C2C-B		Low Low Power	-	0.3	10	
	K6T1008C2C-P		Low power	-	1	50	
	K6T1008C2C-F		Low Low Power	-	0.3	15	

AC OPERATING CONDITIONS

TEST CONDITIONS (Test Load and Test Input/Output Reference)

Input pulse level : 0.8 to 2.4V
 Input rising and falling time : 5ns
 Input and output reference voltage : 1.5V
 Output load (See right) : $C_L = 100\text{pF} + 1\text{TTL}$

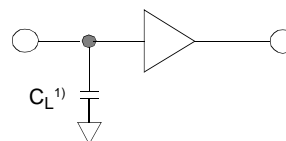

1. Including scope and jig capacitance

AC CHARACTERISTICS

Parameter List		Symbol	Speed Bins				Units
			55ns		70ns		
			Min	Max	Min	Max	
Read	Read cycle time	t _{RC}	55	-	70	-	ns
	Address access time	t _{AA}	-	55	-	70	ns
	Chip select to output	t _{CO1} , t _{CO2}	-	55	-	70	ns
	Output enable to valid output	t _{OE}	-	25	-	35	ns
	Chip select to low-Z output	t _{LZ}	10	-	10	-	ns
	Output enable to low-Z output	t _{OLZ}	5	-	5	-	ns
	Chip disable to high-Z output	t _{HZ}	0	20	0	25	ns
	Output disable to high-Z output	t _{OHZ}	0	20	0	25	ns
	Output hold from address change	t _{OH}	10	-	10	-	ns
Write	Write cycle time	t _{WC}	55	-	70	-	ns
	Chip select to end of write	t _{CW}	45	-	60	-	ns
	Address set-up time	t _{AS}	0	-	0	-	ns
	Address valid to end of write	t _{AW}	45	-	60	-	ns
	Write pulse width	t _{WP}	40	-	50	-	ns
	Write recovery time	t _{WR1} , t _{WR2}	0	-	0	-	ns
	Write to output high-Z	t _{WHZ}	0	20	0	25	ns
	Data to write time overlap	t _{DW}	25	-	30	-	ns
	Data hold from write time	t _{DH}	0	-	0	-	ns
End write to output low-Z	t _{OW}	5	-	5	-	ns	

DATA RETENTION CHARACTERISTICS

Item	Symbol	Test Condition	Min	Typ	Max	Unit	
V _{CC} for data retention	V _{DR}	$\overline{CS}_1 \geq V_{CC} - 0.2V$, $CS_2 \geq V_{CC} - 0.2V$ or $CS_2 \leq 0.2V$	2.0	-	5.5	V	
Data retention current	I _{DR}	$V_{CC} = 3.0V$, $\overline{CS}_1 \geq V_{CC} - 0.2V$, $CS_2 \geq V_{CC} - 0.2V$ or $CS_2 \leq 0.2V$	K6T1008C2C-L	-	1	20	μA
			K6T1008C2C-B	-	1	10	
			K6T1008C2C-P	-	-	25	
			K6T1008C2C-F	-	-	10	
Data retention set-up	t _{SDR}	See data retention waveform	0	-	-	ms	
Recovery time	t _{RDR}		5	-	-		

1. $\overline{CS}_1 \geq V_{CC} - 0.2V$, $CS_2 \geq V_{CC} - 0.2V$ or $CS_2 \leq 0.2V$

TIMMING DIAGRAMS

TIMING WAVEFORM OF READ CYCLE(1) (Address Controlled, $\overline{CS}_1=\overline{OE}=V_{IL}$, $\overline{WE}=V_{IH}$)

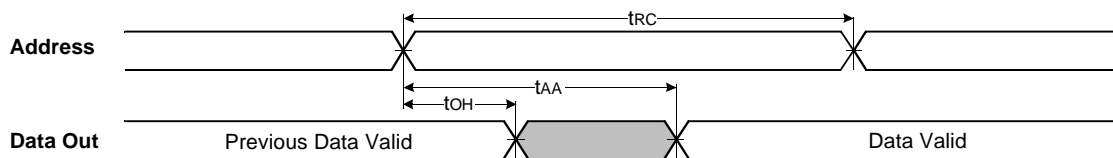

TIMING WAVEFORM OF READ CYCLE(2) ($\overline{WE}=V_{IH}$)

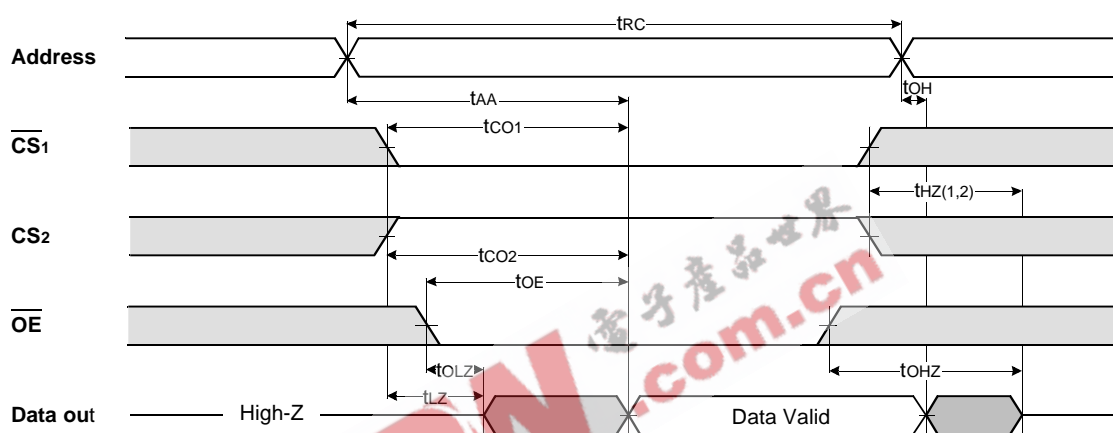

NOTES (READ CYCLE)

1. t_{HZ} and t_{OHZ} are defined as the time at which the outputs achieve the open circuit conditions and are not referenced to output voltage levels.
2. At any given temperature and voltage condition, $t_{HZ}(\text{Max.})$ is less than $t_{LZ}(\text{Min.})$ both for a given device and from device to device interconnection.

TIMING WAVEFORM OF WRITE CYCLE(1) (\overline{WE} Controlled)

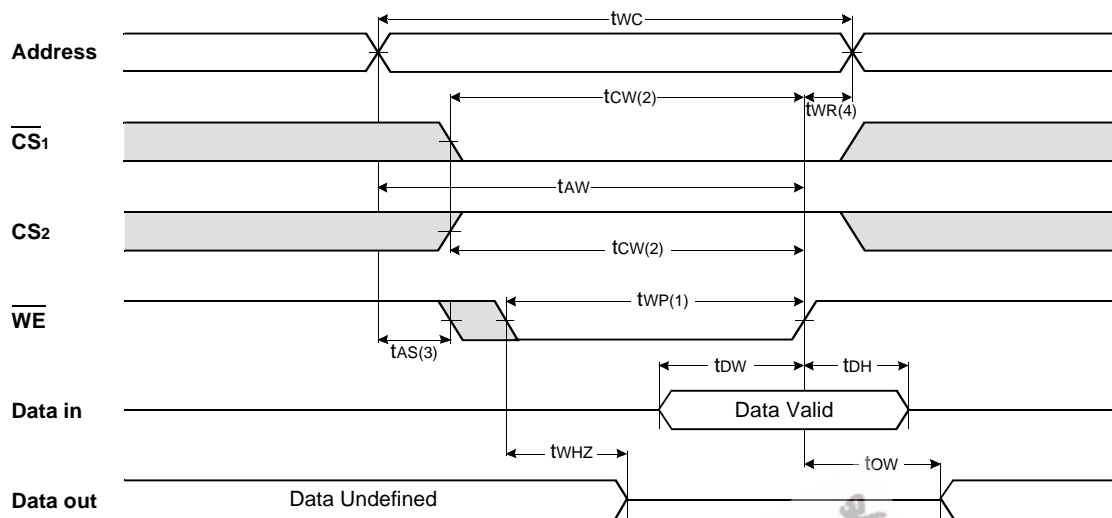

TIMING WAVEFORM OF WRITE CYCLE(2) ($\overline{CS1}$ Controlled)

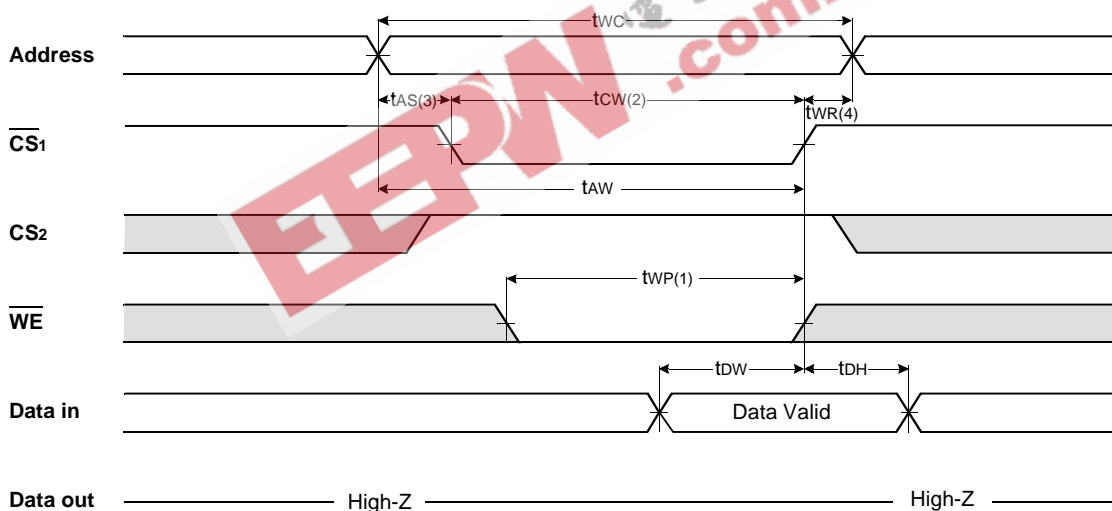

TIMING WAVEFORM OF WRITE CYCLE(3) (CS₂ Controlled)

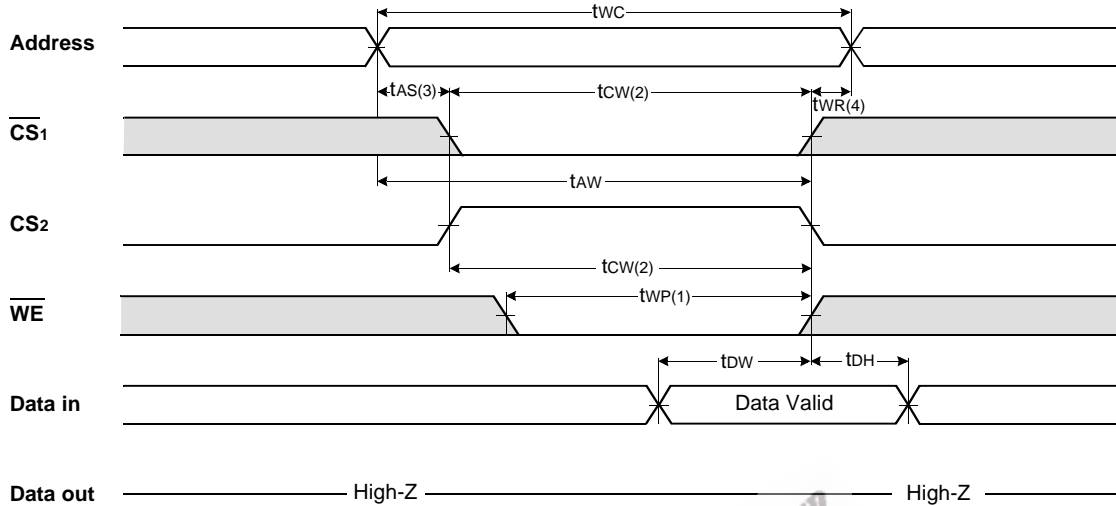

NOTES (WRITE CYCLE)

1. A write occurs during the overlap of a low \overline{CS}_1 , a high CS_2 and a low \overline{WE} . A write begins at the latest transition among \overline{CS}_1 going low, CS_2 going high and \overline{WE} going low : A write end at the earliest transition among \overline{CS}_1 going high, CS_2 going low and \overline{WE} going high, t_{WP} is measured from the beginning of write to the end of write.
2. t_{CW} is measured from the \overline{CS}_1 going low or CS_2 going high to the end of write.
3. t_{AS} is measured from the address valid to the beginning of write.
4. t_{WR} is measured from the end of write to the address change. $t_{WR(1)}$ applied in case a write ends as \overline{CS}_1 or \overline{WE} going high $t_{WR(2)}$ applied in case a write ends as CS_2 going to low.

DATA RETENTION WAVE FORM

\overline{CS}_1 controlled

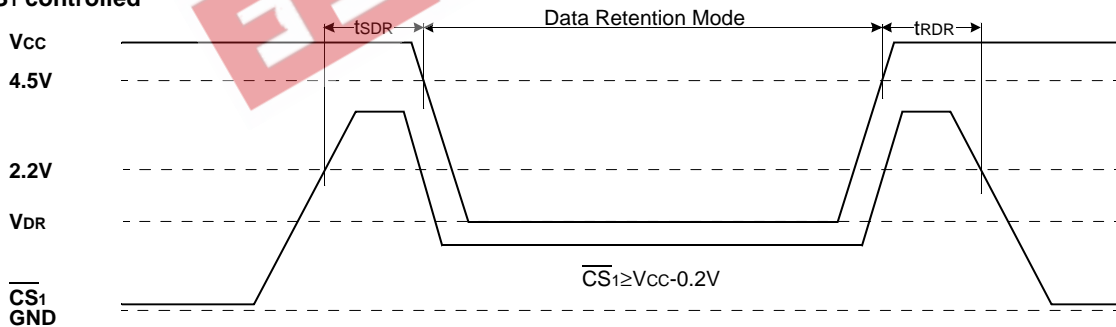

CS₂ controlled

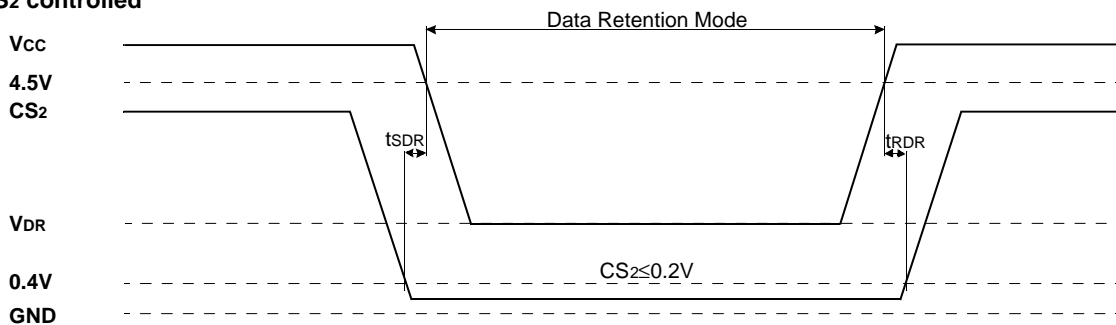

K6T1008C2C Family

CMOS SRAM

PACKAGE DIMENSIONS

Units: millimeter(inch)

32 DUAL INLINE PACKAGE (600mil)

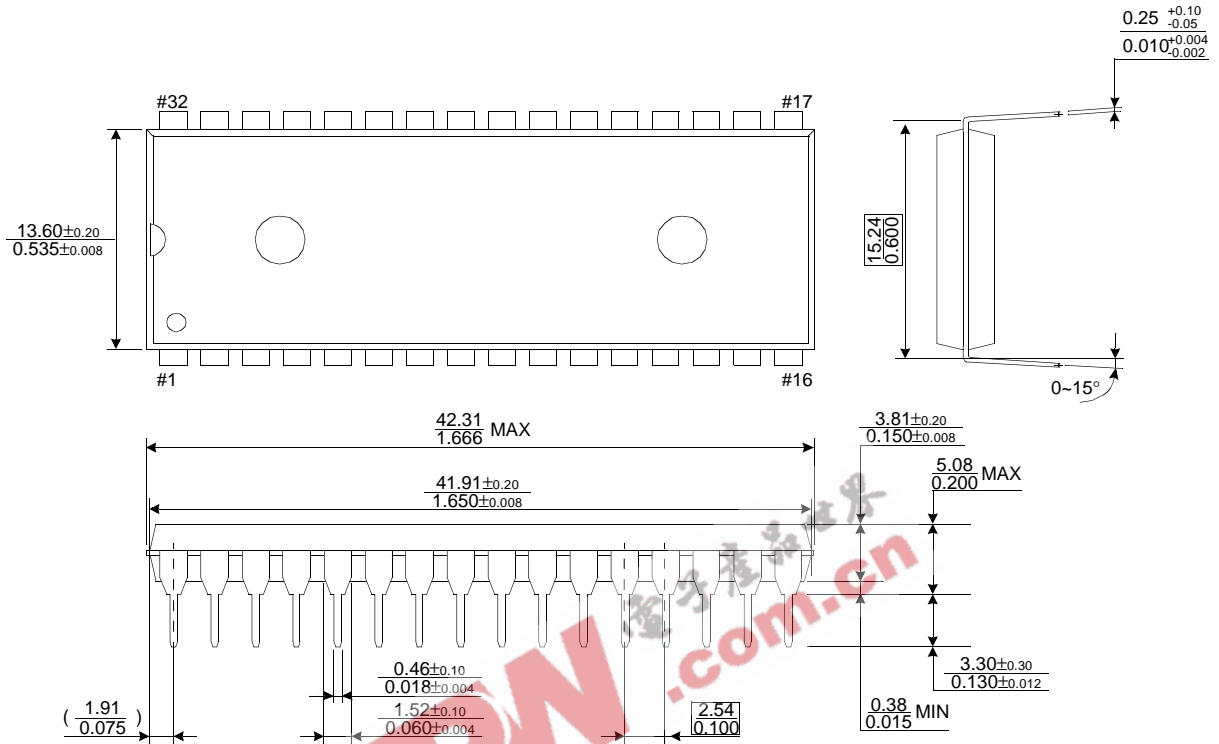

32 PLASTIC SMALL OUTLINE PACKAGE (525mil)

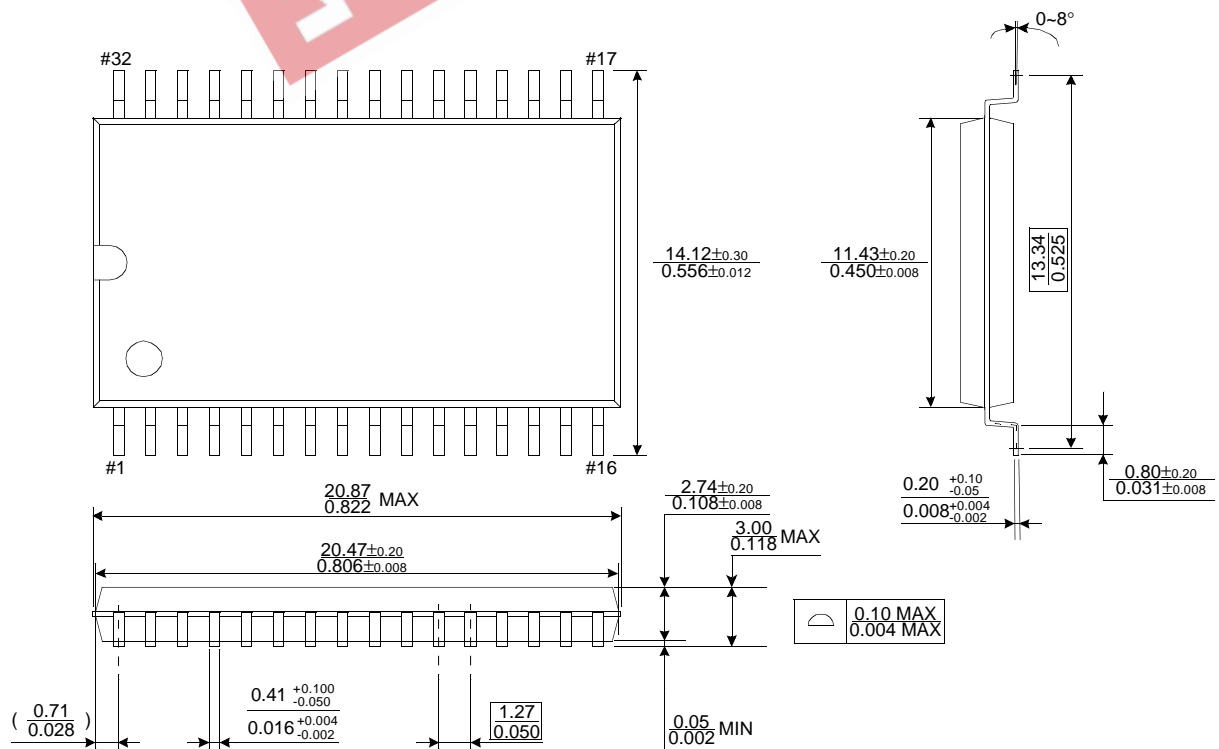

K6T1008C2C Family

CMOS SRAM

PACKAGE DIMENSIONS

Units: millimeter(inch)

32 THIN SMALL OUTLINE PACKAGE TYPE1 (0820F)

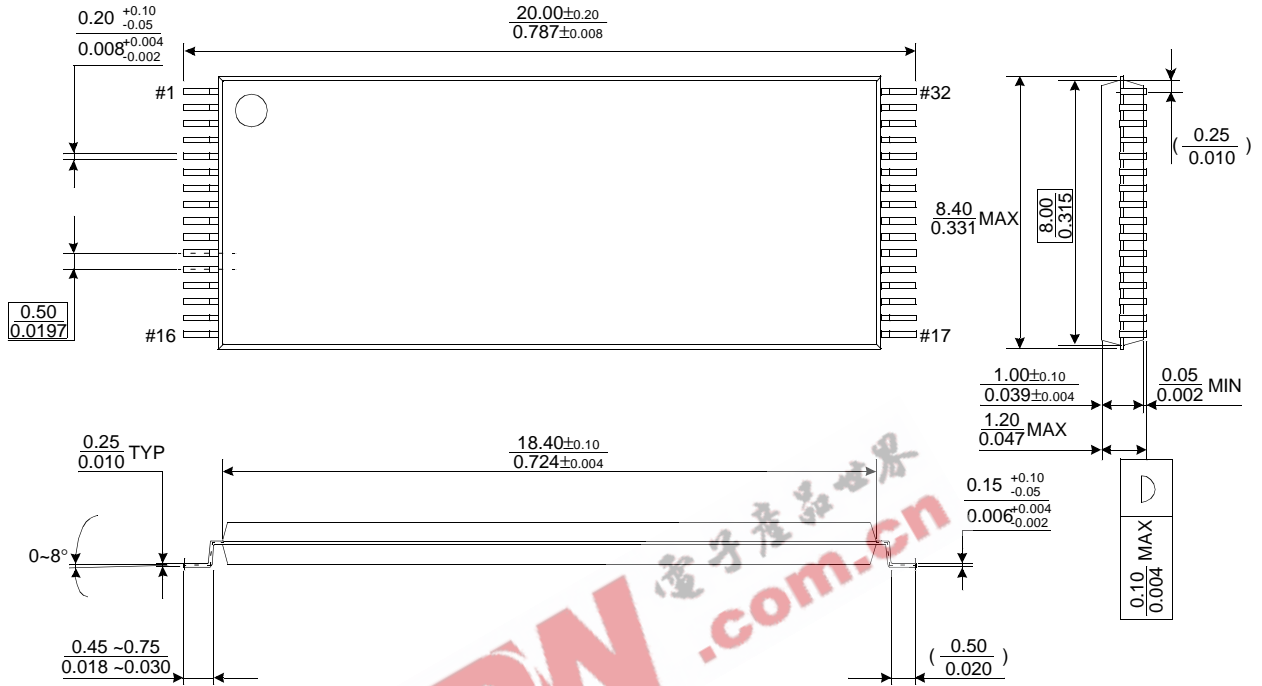

32 THIN SMALL OUTLINE PACKAGE TYPE1 (0820R)

