

Two-color detector K1713/K3413-01, -02

Broad spectral response range from UV through IR

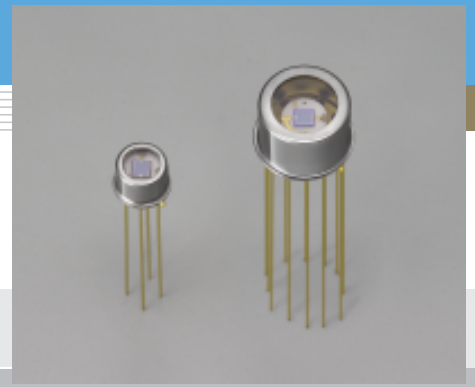

K1713/K3413-01, -02 detectors have a sandwich structure in which an infrared transmitting silicon photodiode is mounted over an infrared detector element. This structure allows you to design instruments using the same optical path from UV through IR.

Features

- Broad spectral response
Suitable for spectrophotometers, flame monitors, etc.
- Noncooled type:
Room temperature operation for easy handling
One-stage thermoelectrically cooled type:
Keeps the detector temperature at a constant level to make high-precision measurements.

Applications

- Spectrophotometers
- Laser monitors
- Flame monitors
- Radiation thermometers

Accessories (Optional)

- Heatsink for thermoelectrically cooled type A3179-03
- Temperature controller for thermoelectrically cooled type C1103-04
- Photosensor amplifier C2719
- Amplifier for PbS and PbSe detectors C3757-02

General ratings / Absolute maximum ratings

Type No.	Dimensional outline/ Window material *1	Package	Cooling	Detector	Active area size (mm)	Absolute maximum ratings									
						Thermistor allowable dissipation (mW)	TE-cooler allowable current (A)	Reverse voltage VR (V)	Operating temperature Topr (°C)	Storage temperature Tstg (°C)					
K1713-01	①/S	TO-5	Non-cooled	Si	2.4 × 2.4	-	-	5	-30 to +50	-55 to +50					
K1713-02				PbS	1.8 × 1.8			100 *2							
K3413-01				②/S	TO-8			One-stage TE-cooled			Si	2.4 × 2.4	0.2	1.5	5
											PbS	1.8 × 1.8			100 *2
K3413-02	Si	2.4 × 2.4	5												
	PbSe	1.8 × 1.8	100 *2												

Electrical and optical characteristics (Typ., unless otherwise noted)

Type No.	Detector	Measurement condition Element temperature T (°C)	Peak sensitivity wavelength λp (μm)	Photo sensitivity S λ=λp (A/W)	Shunt resistance or dark resistance (MΩ)	D* λ=λp (cm · Hz ^{1/2} /W)	Rise time tr VR=0 V RL=1 kΩ 10 to 90 % (μs)
K1713-02	PbS	25	2.2	6 × 10 ⁴ (V/W)	0.2 to 2	5 × 10 ¹⁰ *3	200 Max. *5
	Si		0.94	0.45	300	1.4 × 10 ¹³	0.2 *4
K3413-01	PbSe	25	4.0	5 × 10 ² (V/W)	0.5 to 1.8	5 × 10 ⁸ *3	3 Max. *5
	Si		0.94	0.45	300	1.4 × 10 ¹³	0.2 *4
K3413-02	PbS	-10	2.4	3 × 10 ⁵ (V/W)	0.5 to 10	1 × 10 ¹¹ *3	600 Max. *5
	Si	25	0.94	0.45	300	1.4 × 10 ¹³	0.2 *4
K3413-02	PbSe	-10	4.1	1.5 × 10 ³ (V/W)	1.5 to 5	1 × 10 ⁹ *3	5 Max. *5

*1: Window material S: sapphire glass

*2: Maximum supply voltage

*3: Light source 500 K black body
Chopping frequency: 600 Hz,
Noise bandwidth: 60 Hz

*4: λ=655 nm

*5: 0 to 63 %

Supply voltage: 15 V

Load resistance: nearly equal to element dark resistance

Input energy: 4.8 μW/cm² (PbSe: 16.7 μW/cm²)

SOLID STATE DIVISION

■ Spectral response

Si photodiode

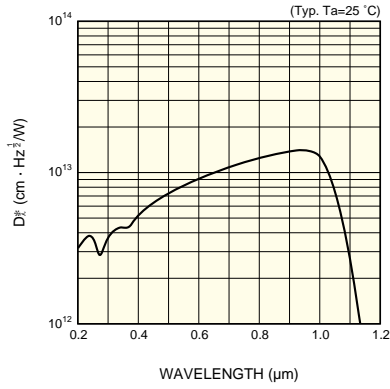

KIRDB0058EE

PbS photoconductive detector

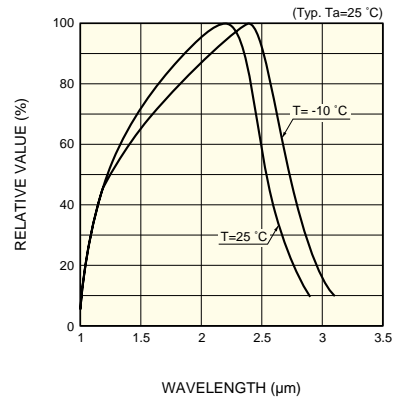

KIRDB0282EA

PbSe photoconductive detector

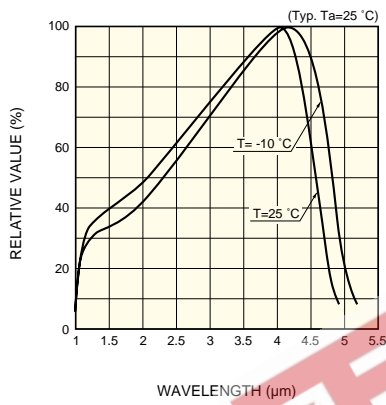

KIRDB0283EA

■ Cooling characteristics of TE-cooler

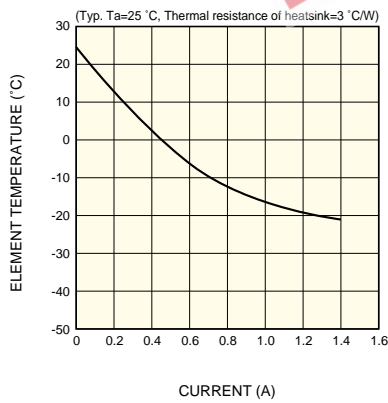

KIRDB0276EA

■ Current vs. voltage characteristics of TE-cooler

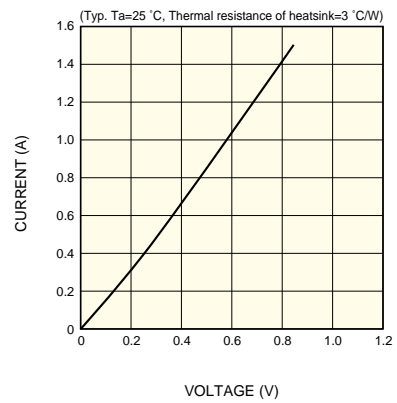

KIRDB0277EA

■ Thermistor temperature characteristic

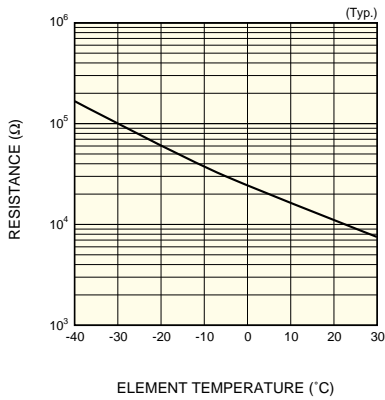

KIRD80278EA

■ Dimensional outline (unit: mm)

① K1713-01, -02

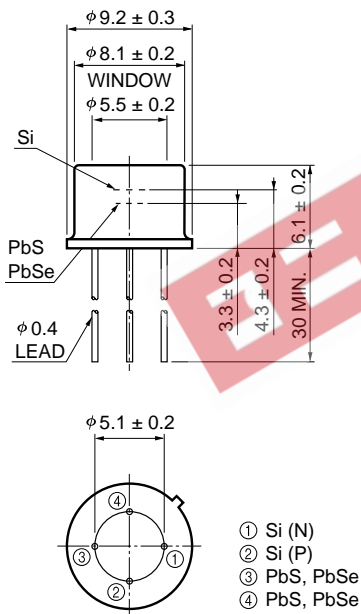

KIRDA0041EE

② K3413-01, -02

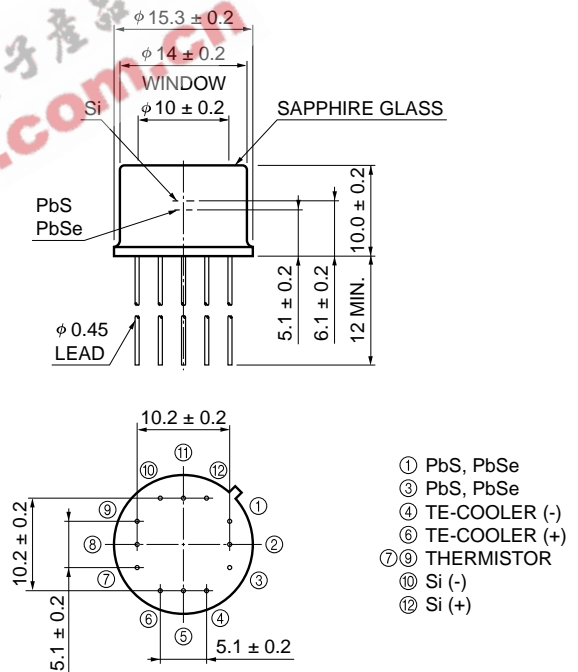

KIRDA0043EE