

SWITCHING APPLICATION.
INTERFACE CIRCUIT AND DRIVER CIRCUIT APPLICATION.

FEATURES

- With Built-in Bias Resistors.
- Simplify Circuit Design.
- Reduce a Quantity of Parts and Manufacturing Process.

EQUIVALENT CIRCUIT

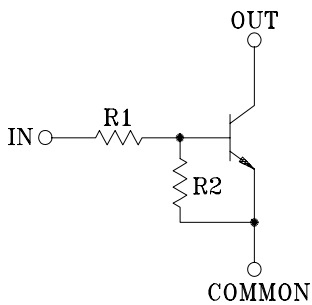

BIAS RESISTOR VALUES

TYPE NO.	R1(kΩ)	R2(kΩ)
KRC107M	10	47
KRC108M	22	47
KRC109M	47	22

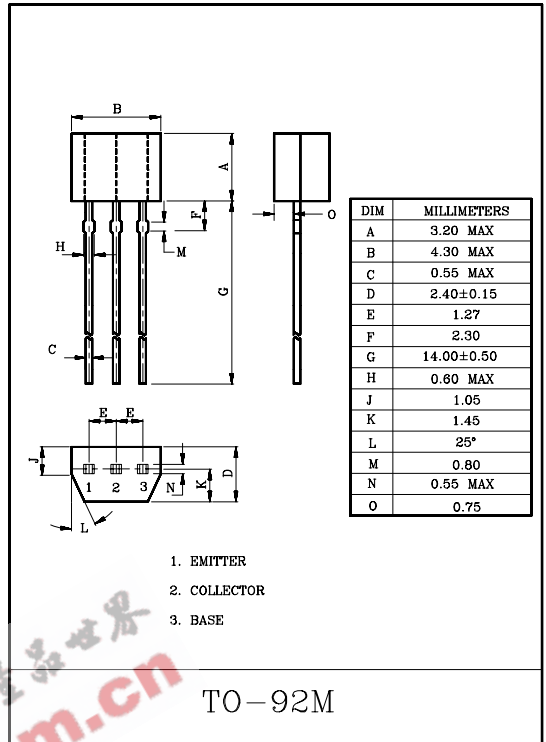

MAXIMUM RATINGS (Ta=25°C)

CHARACTERISTIC	SYMBOL	RATING	UNIT
Output Voltage	KRC107M ~109M V _o	50	V
Input Voltage	KRC107M	30, -6	V
	KRC108M	40, -7	
	KRC109M	40, -15	
Output Current	I _o	100	mA
Power Dissipation	P _D	400	mW
Junction Temperature	T _j	150	°C
Storage Temperature Range	T _{stg}	-55~150	°C

KRC107M~KRC109M

ELECTRICAL CHARACTERISTICS (Ta=25°C)

CHARACTERISTIC		SYMBOL	TEST CONDITION	MIN.	TYP.	MAX.	UNIT	
Output Cut-off Current	KRC107M~109M	$I_{O(OFF)}$	$V_O=50V, V_I=0$	-	-	500	nA	
DC Current Gain	KRC107M	G_I	$V_O=5V, I_O=10mA$	80	150	-		
	KRC108M			80	150	-		
	KRC109M			70	140	-		
Output Voltage	KRC107M~109M	$V_{O(ON)}$	$I_O=10mA, I_f=0.5mA$	-	0.1	0.3	V	
Input Voltage (ON)	KRC107M	$V_{I(ON)}$	$V_O=0.2V, I_O=5mA$	-	1.2	1.8	V	
	KRC108M			-	1.8	2.6		
	KRC109M			-	3.0	5.8		
Input Voltage (OFF)	KRC107M	$V_{I(OFF)}$	$V_O=5V, I_O=0.1mA$	0.5	0.75	-	V	
	KRC108M			0.6	0.88	-		
	KRC109M			1.5	1.82	-		
Transition Frequency	KRC107M~109M	f_T *	$V_O=10V, I_O=5mA$	-	200	-	MHz	
Input Current	KRC107M	I_I	$V_I=5V$	-	-	0.88	mA	
	KRC108M			-	-	0.36		
	KRC109M			-	-	0.16		
Switching Time	Rise Time	KRC107M	$V_O=5V$ $V_{IN}=5V$ $R_L=1k\Omega$	-	0.05	-	μS	
		KRC108M		-	0.12	-		
		KRC109M		-	0.26	-		
	Storage Time	KRC107M		t_{stg}	-	2.0		-
		KRC108M			-	2.4		-
		KRC109M			-	1.5		-
	Fall Time	KRC107M		t_f	-	0.36		-
		KRC108M			-	0.4		-
		KRC109M			-	0.41		-

Note : * Characteristic of Transistor Only

KRC107M~KRC109M

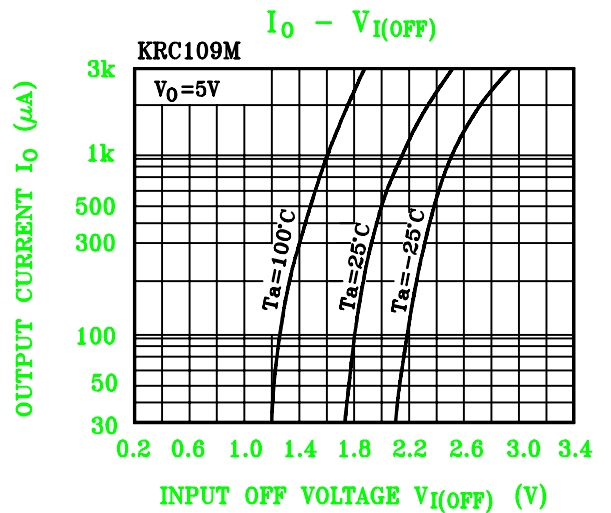
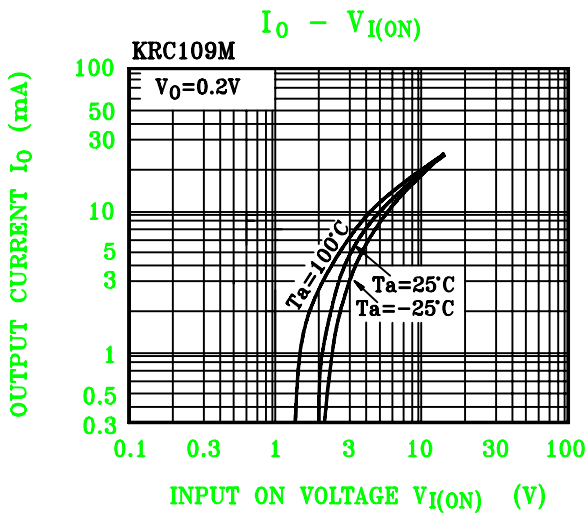
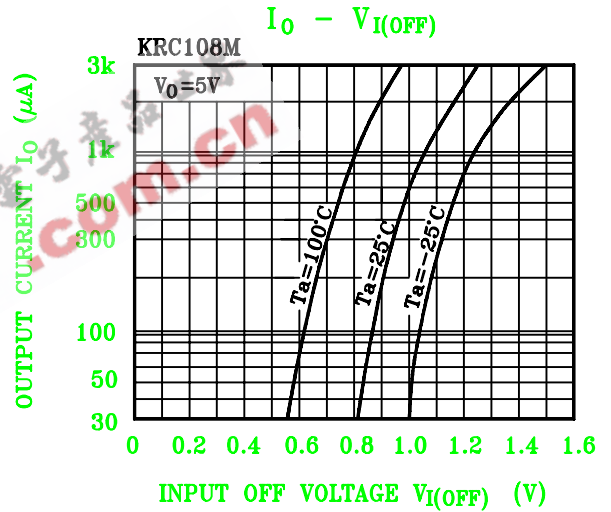
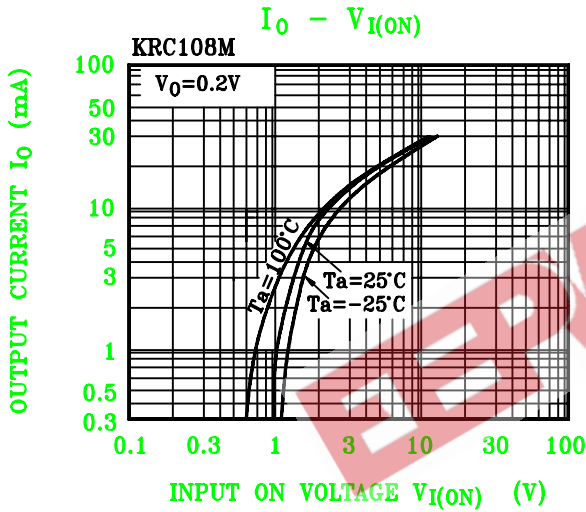
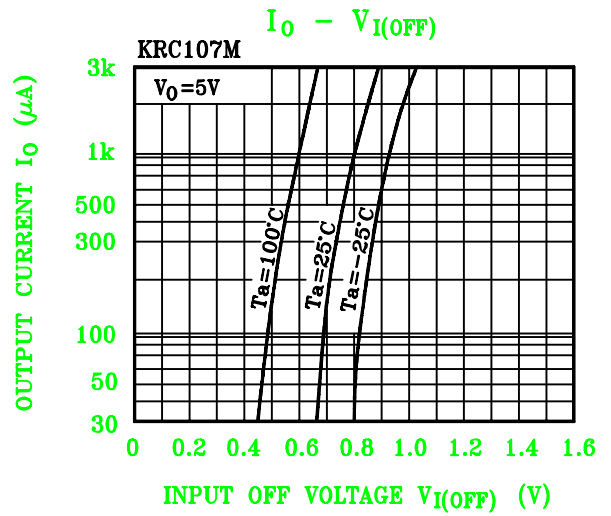
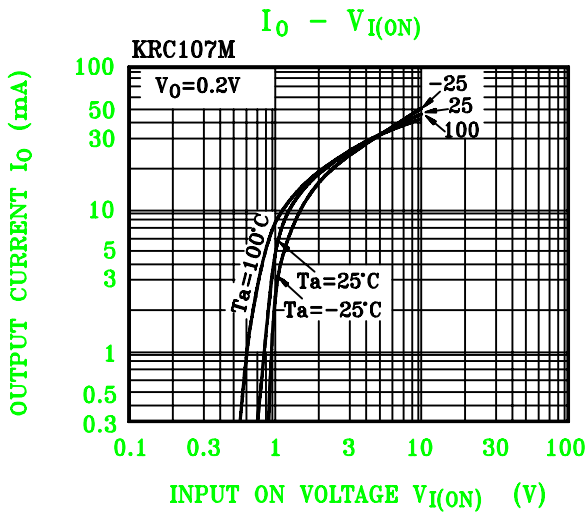

KRC107M ~ KRC109M

