

KA8602B

LOW VOLTAGE AUDIO AMPLIFIER

INTRODUCTION

The KA8602B is the audio power amplifier available for low voltages. KA8602B supplies differential outputs for maximizing output swing at low voltages. KA8602B doesn't need coupling capacitors to the speaker. The gain of this amp is controlled easily by two external resistors.

FEATURES

- | Wide Supply Voltage (2 ~ 16V)
- | Low Quiescent Supply Current ($I_{CC} = 2.7\text{mA}$: Typ)
- | Easy Gain Control
- | Medium Output Power
 $P_O = 250\text{mW}$ at $V_{CC} = 6\text{V}$, $R_L = 32\Omega$, THD = 10%
- | Minimum External Parts
- | Load Impedance Range ($8\Omega \sim 100\Omega$)
- | Low Distortion
- | Mute Function ($I_{CC} = 65\mu\text{A}$: Typ)

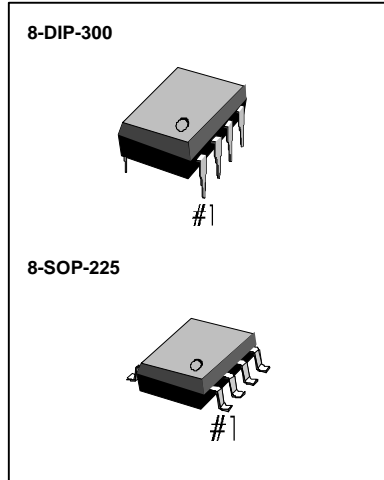

ORDERING INFORMATION

Device	Package	Operating Temperature
KA8602B	8-DIP-300	- 20°C ~ + 70°C
KA8602BD	8-SOP-225	

BLOCK DIAGRAM

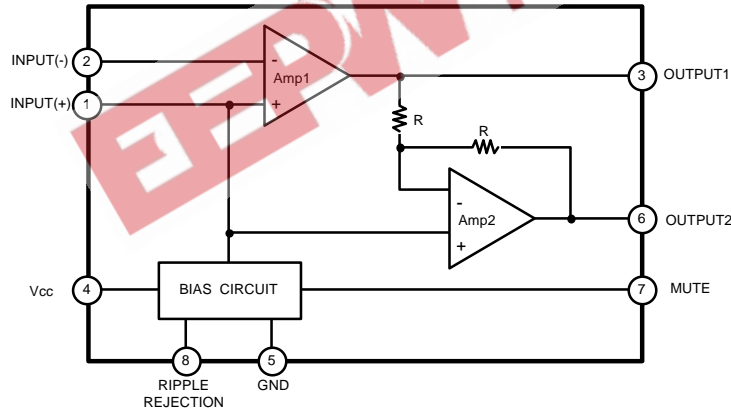

Fig. 1

PIN CONFIGURATION

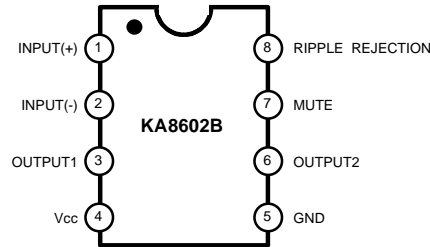

Fig. 2

PIN DESCRIPTION

Pin No	Symbol	Description
1	Input (+)	Analog Ground for the amplifiers. A 1.0 μ F capacitor at this pin (with a 5.0 μ F capacitor at pin 8) provides 52dB (Typ) of power supply rejection. Turn-on time of the circuit is affected by the capacitor on this pin. This pin can be used as an alternative input.
2	Input (-)	Amplifier input. The input capacitor and resistor set low frequency roll-off and input impedance. The feedback resistor is connected between this pin and output1.
3	Output 1	Amplifier 1's output. The DC Level is $\frac{1}{2}(V_{CC} - 0.7V)$.
4	V _{CC}	DC supply voltage (+2.0 ~ + 16V) is applied to this pin.
5	GND	Ground pin.
6	Output 2	Amplifier 2's output. This signal is equal in amplitude, but 180° out of phase with that at output1. The DC level is $\frac{1}{2}(V_{CC} - 0.7V)$.
7	Mute	This pin can be used to power down the IC to conserve power, or for muting, or both. When at a logic "Low" (0 to 0.8 volts), the KA8602B is enabled for normal operation. When at a logic "High" (2.0 to V _{CC} volts), the IC is disabled. If Mute is open, that is equivalent to a logic "Low".
8	Ripple Rejection	A capacitor at this pin increases power supply rejection, and affects turn-on time. This pin can be left open if the capacitor at pin 1 is sufficient.

ABSOLUTE MAXIMUM RATINGS

Characteristic	Symbol	Vale	Unit
Supply Voltage	V _{CC}	- 1.0 ~ + 18	V
Output Current (output pin)	I _O	± 250	mA
Maximum Voltage (input, Ripple rejection, Mute pin)	V _{I(MAX)}	- 1.0 ~ V _{CC} + 1.0	V
Applied Output Voltage (output pin) when disabled	V _O	- 1.0 ~ V _{CC} + 1.0	V
Junction Temperature	T _J	- 55 ~ + 140	°C

RECOMMENDED OPERATING CONDITIONS (Ta = 25°C)

Characteristic	Symbol	Min	Typ	Max	Unit
Supply Voltage	V _{CC}	+2.0		+16	V
Load Impedance	Z _L	8		100	Ω
Peak Load Current	I _{L (PK)}			± 200	mA
Differential Gain (5KHz Bandwidth)	ΔG _V	0		46	dB
Voltage at Mute (Pin 7)	V _{I (MUTE)}	0		V _{CC}	V
Ambient Temperature	Ta	-20		470	°C

ELECTRICAL CHARACTERISTIC

(V_{CC} = 6V, Ta = 25°C, unless otherwise noted)

Characteristic	Symbol	Test Conditions	Min	Typ	Max	Unit	
DC ELECTRICAL CHARACTERISTICS							
Operating Current (R _L = 0)	I _{CC}	V _{CC} = 3.0V, Mute = 0.8V		2.7	4.0	mA	
		V _{CC} = 16.0V, Mute = 0.8V		3.3	5.0	mA	
		V _{CC} = 3.0V, Mute = 2.0V		65	100	μA	
Output Voltage (output pin)	V _O	R _L = 16Ω R ₁ = 75KΩ	V _{CC} = 3.0V V _{CC} = 6.0V V _{CC} = 12.0V	1.0	1.15 2.65 5.65	1.25	V
Output Offset Voltage	V _{OO}	V _{CC} = 6.0V, R _f = 75KΩ, R _L = 32Ω	-30	0	+30	mV	
Output High Level	V _{OH}	2.0V ≤ V _{CC} ≤ 16V, I _{out} = -75mA		V _{CC} -1.0		V	
Output Low Level	V _{OL}	2.0V ≤ V _{CC} ≤ 16V, I _{out} = 75mA		0.16		V	
Input Bias Current (pin 2)	I _{BIAS}			-100	-200	nA	
Equivalent Resistance	R _{EQ}	pin 1	100	150	220	KΩ	
		pin 8	18	25	40	KΩ	
Mute	Input Low Voltage	V _{IL (MUTE)}			0.8	V	
	Input High Voltage	V _{IH (MUTE)}	2.0			V	
	Input Resistance	R _{I (MUTE)}	V _{CC} = Mute = 16V	50	90	175	KΩ
AC ELECTRICAL CHARACTERISTICS							
Open Loop Gain (Amp 1)	G _{V (AMP1)}		80			dB	
Close Loop Gain (Amp 2)	G _{V (AMP2)}	f = 1.0KHz, R _L = 32Ω	-0.35	0	+0.35	dB	
Output Power	P _O	V _{CC} = 3.0V, R _L = 6Ω, THD ≤ 10%	55			mW	
		V _{CC} = 6.0V, R _L = 32Ω, THD ≤ 10%	250			mW	
		V _{CC} = 12V, R _L = 100Ω, THD ≤ 10%	400			mW	
Total Harmonic Distortion (f = 1.0KHz)	THD	V _{CC} = 6.0V, R _L = 32Ω, P _O = 125mW		0.5	1.0	%	
		V _{CC} ≤ 3.0V, R _L = 8Ω, P _O = 20mW		0.5		%	
		V _{CC} ≤ 12V, R _L = 32Ω, P _O = 200mW		0.6		%	
Gain Bandwidth Product	GBW			1.5		MHz	
Power Supply Rejection (V _{CC} = 6.0V, ΔV _{CC} = 3.0V)	PSRR	C ₁ = ∞, C ₂ = 0.01μF	50			dB	
		C ₁ = 0.1μF, C ₂ = 0, f = 1.0KHz		12		dB	
		C ₁ = 1.0μF, C ₂ = 5.0μF, f = 1.0KHz		52		dB	
Muting	G _{V (MUTE)}	Mute = 2.0V, 1.0KHz ≤ f ≤ 20KHz		> 70		dB	

KA8602B

LOW VOLTAGE AUDIO AMPLIFIER

APPLICATION CIRCUIT

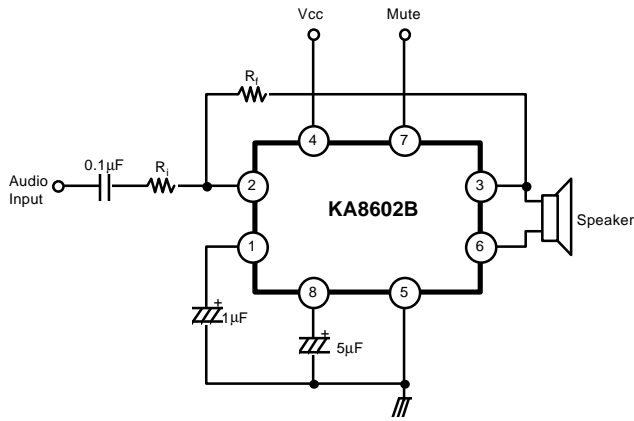

Fig. 3

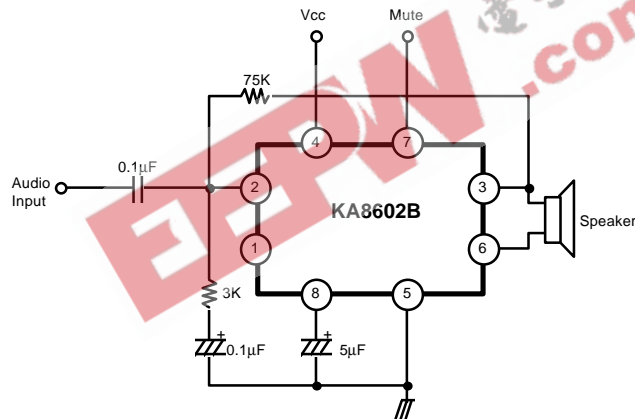

Fig. 4

KA8602B

LOW VOLTAGE AUDIO AMPLIFIER

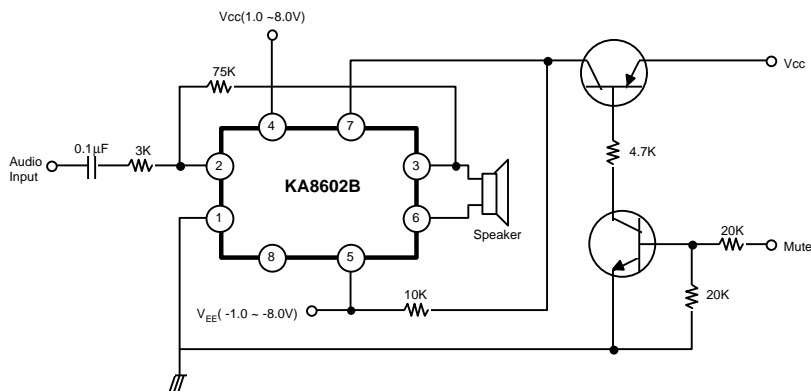

Fig. 5

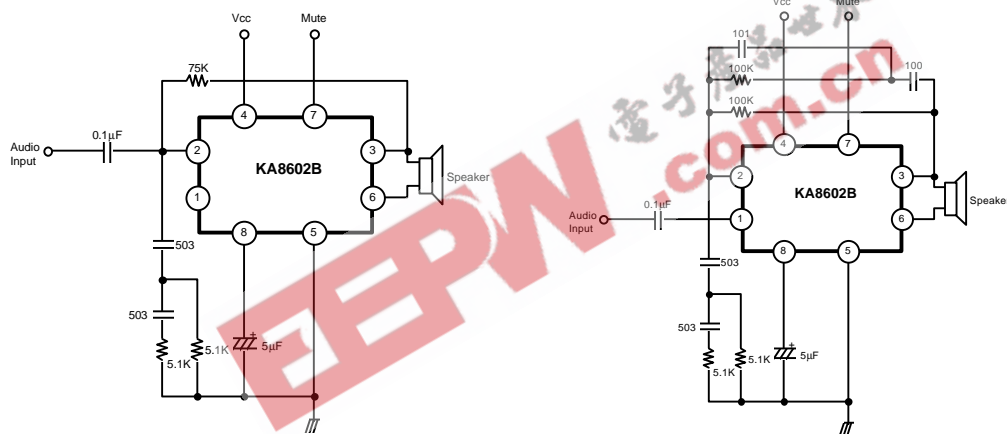

Fig. 6

Fig. 7