

### General Description

The KB3301 is a small, high efficiency, and low voltage step-up DC/DC converter with an Adaptive Current Mode PWM control loop, includes an error amplifier, ramp generator, comparator, switch pass element and driver in which providing a stable and high efficient operation over a wide range of load currents. It operates in stable waveforms without external compensation.

The low start-up input voltage below 0.8V makes KB3301 suitable for 1 to 4 battery cells applications of providing up to 300mA output current. The 500KHz high switching rate minimized the size of external components. Besides, the 14µA low quiescent current together with high efficiency maintains long battery lifetime.

The KB3301 is available in small package SOT-26 and SOT89-5

### Features

- ◆ 90% Efficiency
- ◆ High Supply Capability to Deliver 5.0V 500mA with input 3.6V-4.2V
- ◆ 14µA Quiescent (switch-off) Supply Current
- ◆ 500KHz Fixed Switching Frequency
- ◆ Zero Shutdown Mode Supply Current
- ◆ Providing Flexibility for Using Internal and External Power Switches
- ◆ 1.0V Low Start-up Input Voltage
- ◆ Small SOT-26 & SOT89-5 Package

#### Ordering Information

Item	Package	Shipping
KB3301MR	SOT-26	3000pcs/Reel&Tape
KB3301PR	SOT-89-5	3000pcs/Reel&Tape

### Applications

- ◆ LCD Panel
- ◆ DSC
- ◆ MP3
- ◆ Wireless Equipment
- ◆ Portable Instrument
- ◆ PDA

#### Package Information

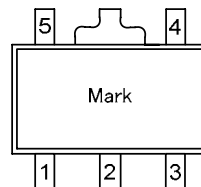

SOT89-5

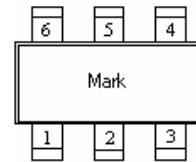

SOT-26

### Typical Application Circuit

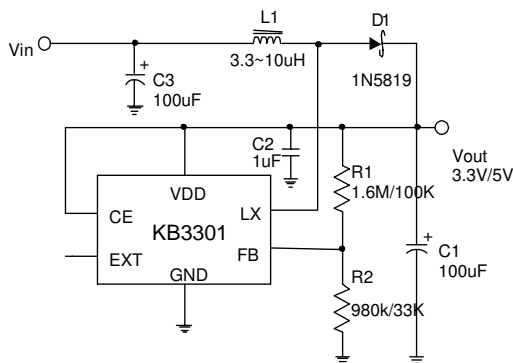

Note: Vin=3.6~4.2V, Vout=5.0V 500mA ( USB host application )

#### Pin Configurations

SOT-26	SOT-89-5	Pin Name	Pin Function
1	1	CE	Chip enable
2		EXT	Output
3	5	GND	Ground
4	4	LX	Switching
5	2	VDD	Input
6	3	FB	Feedback input 1.25V

### Function Block Diagram

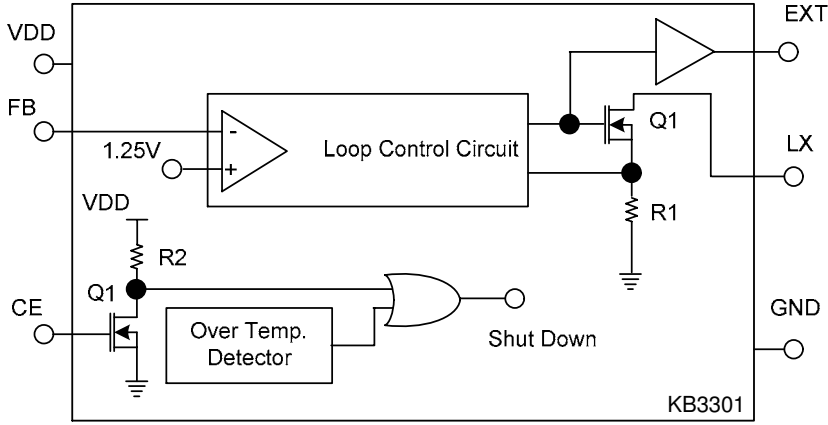

### Marking Information

	Symbol	Description
①	1	Step-up DC-DC Converter
②	3	KB3301
③④	01	Control Code

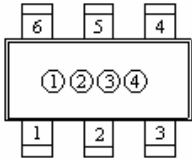

SOT-26

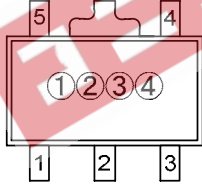

SOT-89-5

### Test Circuit

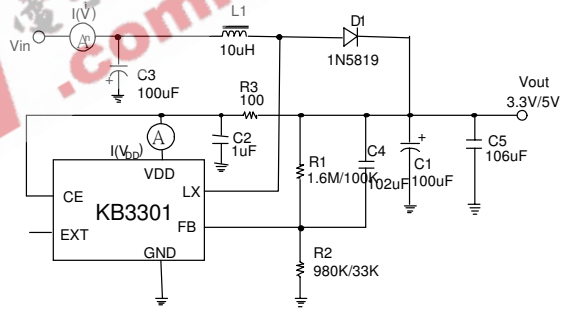

## ABSOLUTE MAXIMUM RATINGS (Ta=25°C)

Parameter	Symbol	Ratings	Unit	
Supply Voltage	V <sub>in</sub>	- 0.3V ~ 7V	V	
LX Pin Switch Voltage	V <sub>Lx</sub>	- 0.3 ~ (VDD + 0.8V)	V	
Other I/O Pin Voltages	V <sub>ss</sub>	- 0.3V ~ (VDD + 0.3V)	V	
Lx Pin Switch Current	I <sub>Lx</sub>	2.5	A	
EXT Pin Driver Current	I <sub>EXT</sub>	200	mA	
Package Thermal Resistance	SOT-26	Pd	145	°C/W
	SOT-89-5		45	°C/W
Operating Junction Temperature	T <sub>j</sub>	125	°C	
Storage Temperature Range	T <sub>stg</sub>	- 65 ~ +150	°C	

## ELECTRICAL CHARACTERISTICS

(V<sub>in</sub> = 1.5V, VDD=3.3V, I<sub>L</sub>=0, Ta = 25°C, unless otherwise spec

Parameter	Symbol	Test Conditions	Min	Typ	Max	Units
Start-UP Voltage	V <sub>ST</sub>	I <sub>L</sub> = 1mA	--	0.80	0.85	V
Operating VDD Range	V <sub>DD</sub>	VDD pin voltage	2	--	6.5	V
No Load Current I (V <sub>IN</sub> )	I <sub>NO LOAD</sub>	V <sub>IN</sub> = 1.5V, V <sub>OUT</sub> = 3.3V	--	75	--	μA
Switch-off Current I (VDD)	I <sub>SWITCH OFF</sub>	V <sub>IN</sub> = 6V	--	14	--	μA
Shutdown Current I (V <sub>IN</sub> )	I <sub>OFF</sub>	CE Pin = 0V, V <sub>IN</sub> = 4.5V	--	0.01	1	μA
Feedback Reference Voltage	V <sub>REF</sub>	Close Loop, VDD = 3.3V	1.225	1.25	1.275	V
Switching Frequency	F <sub>S</sub>	VDD = 3.3V	--	500	--	KHz
Maximum Duty	D <sub>MAX</sub>	VDD = 3.3V	--	95	--	%
LX ON Resistance		VDD = 3.3V	--	0.3	--	Ω
Current Limit Setting	I <sub>LIMIT</sub>	VDD = 3.3V	--	2	--	A
EXT ON Resistance to VDD		VDD = 3.3V	--	5	--	Ω
EXT ON Resistance to GND		VDD = 3.3V	--	5	--	Ω
Line Regulation	ΔV <sub>LINE</sub>	V <sub>IN</sub> = 1.5 ~ 2.5V, I <sub>L</sub> = 1mA	--	10	--	mV/V
Load Regulation	ΔV <sub>LOAD</sub>	V <sub>IN</sub> = 2.5V, I <sub>L</sub> = 1 ~ 100mA	--	0.25	--	mV/mA
CE Pin Trip Level		VDD = 3.3V	0.4	0.8	1.2	V
Temperature Stability for Vout	T <sub>S</sub>		--	50	--	ppm/°C
Thermal Shutdown	T <sub>SD</sub>		--	165	--	°C
Thermal Shutdown Hysterises	ΔT <sub>SD</sub>		--	10	--	°C

\* Note: The CE pin shall be tied to VDD pin and inhibit to act the ON/OFF state whenever the VDD pin voltage may reach to 5.5V or above.



## PACAGE DESCRIPTION

### ● SOT-89-5

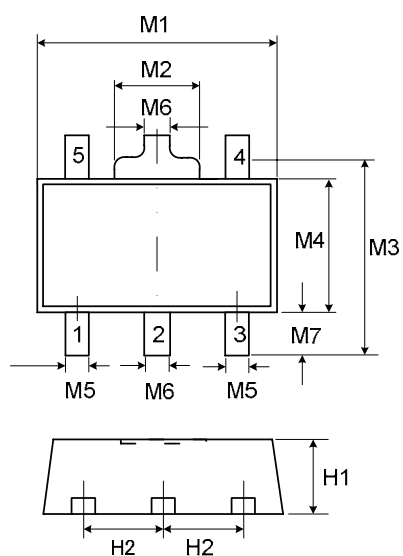

Units: mm

Symbol	Min	Max
A	1.400	1.600
b	0.360	0.520
B	2.400	2.600
b1	0.406	0.533
C	--	4.250
C1	0.800	--
D	4.400	4.600
D1	--	1.700
e	1.400	1.600
H	0.380	0.430

### ● SOT-26

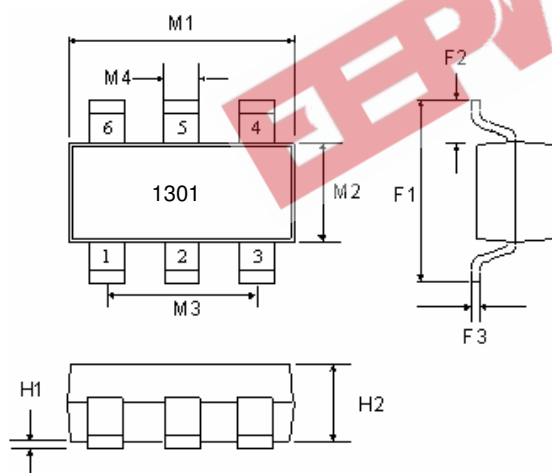

Units: mm

Symbol	Min	Max
A	0.889	1.295
A1	--	0.152
B	1.397	1.803
b	0.356	0.559
C	2.591	2.997
D	2.692	3.099
e	0.838	1.041
H	0.102	0.254
L	0.356	0.610