

AFC APPLICATION FOR FM RECEIVER.

FEATURES

- High Q : Q=70(Min.) (f=50MHz).
- Low Reverse Current : $I_R=100\text{nA(Max.)}$ ($V_R=4\text{V}$).

MAXIMUM RATINGS ($T_a=25^\circ\text{C}$)

CHARACTERISTIC	SYMBOL	RATING	UNIT
Reverse Voltage	V_R	15	V
Junction Temperature	T_j	150	$^\circ\text{C}$
Storage Temperature Range	T_{stg}	-55~150	$^\circ\text{C}$

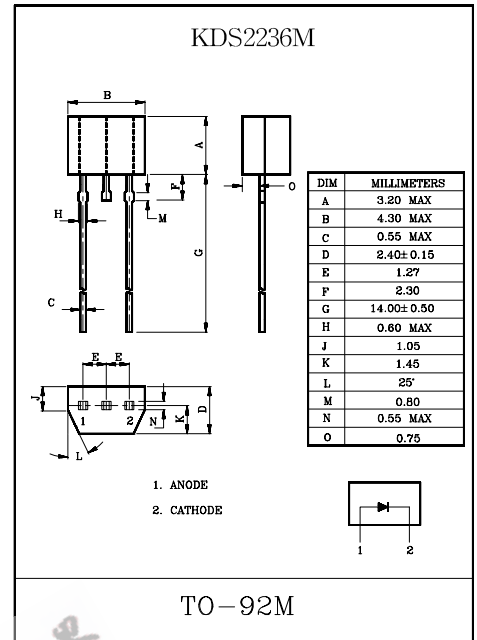

Marking

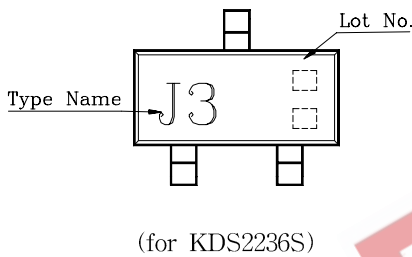

Marking (for KDS2236M)

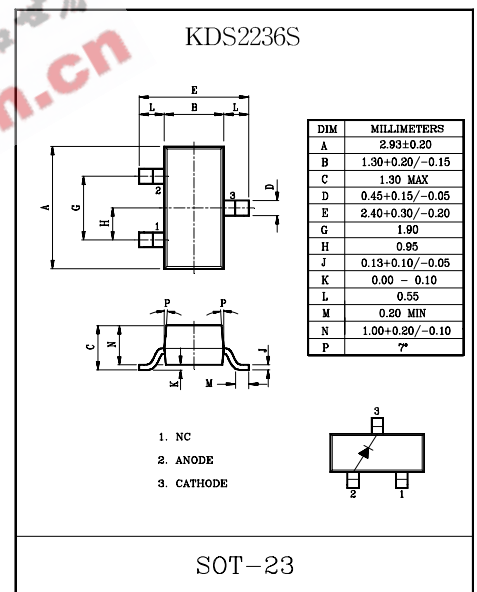
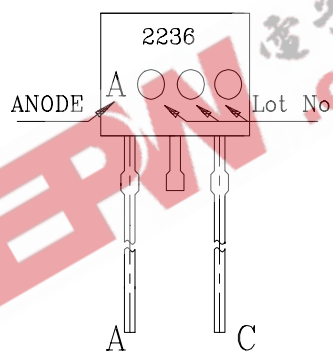

ELECTRICAL CHARACTERISTICS ($T_a=25^\circ\text{C}$)

CHARACTERISTIC	SYMBOL	TEST CONDITION	MIN.	TYP.	MAX.	UNIT
Reverse Current	I_R	$V_R=4\text{V}$	-	-	100	nA
Total Capacitance	C_T	$V_R=4\text{V}, f=1\text{MHz}$	7.0	-	14	pF
Capacitance Ratio	K	(Note)	0.210	-	0.5	
Figure of Merit	Q	$V_R=4\text{V}, f=50\text{MHz}$	70	120	-	

Note) $K = \frac{C_T(@V_R=2\text{V}, f=1\text{MHz}) - C_T(@V_R=4\text{V}, f=1\text{MHz})}{C_T(@V_R=4\text{V}, f=1\text{MHz})}$

KDS2236M/S

