



Step-Up DC-DC Converter

General Description

The KB2301 Series are PFM step-up DC-DC converters with very low ripple noise due to the high operation frequency. The maximum operation frequency is 400KHz.

Only three components are required to realize the conversion from the battery voltage to a selected output voltage.

A driver pin (EXT) is provided for driving external power transistor to extend the output current capability where large current is required.

Enable pin (EN) is also provided so that the circuit can be powered down.

Ordering Information

KB2301 **X** **X** **X** **X**

Package Type:

- T: SOT-23-3
- F: SOT-23-5
- E: SOT-89

Output Voltage:

- 20: 2.0V
- 21: 2.1V
- ...
- 49: 4.9V
- 50: 5.0V

External switch

- E: use external switch
- L: use internal switch

Features

- 400KHz Maximum Operation Frequency
- 2.0V to 5.0V Output Voltage With 0.1V Step
- Low Start-up Voltage: 0.8V at 1mA
- ± 2% Output Voltage Accuracy
- Up to 88% Efficiency
- Output current: 300mA at 2.5V input, 3.3V output
- Low Ripple and Low Noise
- Output Current Extendable by External Switch

Applications

- Power source for applications where a higher voltage than the battery voltage is required
- One to three cell battery devices
- Power source for cameras, camcorders, VCRs, PDAs, pagers and hand held communication instrument

Typical Applications

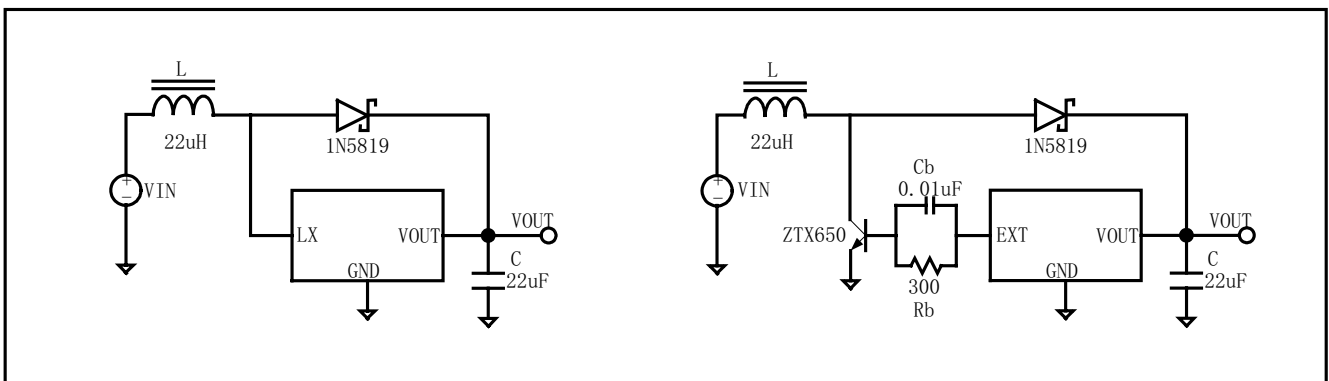



Block Diagram

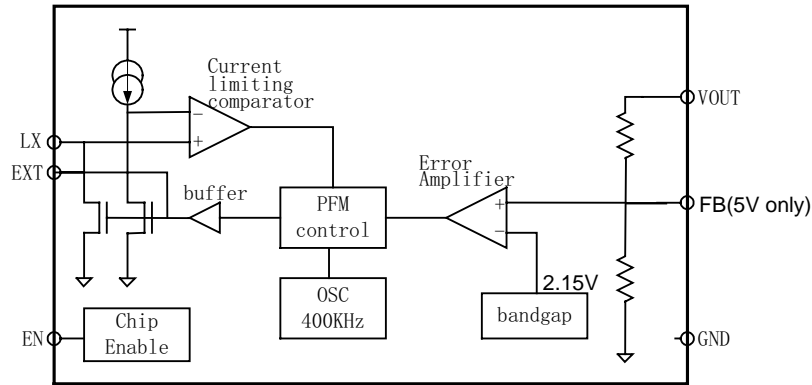

Pin Assignment

Pin Name	Part Marking and Package Type						Description
	KB2301 LXXT SOT-23-3	KB2301 LXXF SOT-23-5	KB2301 LXXE SOT-89	KB2301 EXXT SOT-23-3	KB2301 EXXF SOT-23-5	KB2301 EXXE SOT-89	
LX	2	5	3	-	-	-	Switching pin
EXT	-	-	-	2	5	3	Buffer output for external transistor
VOUT	3	2	2	3	2	2	Output voltage
EN	-	1	-	-	1	-	Chip enable (active high)
GND	1	4	1	1	4	1	Ground
FB	-	3	-	-	3	-	5V only

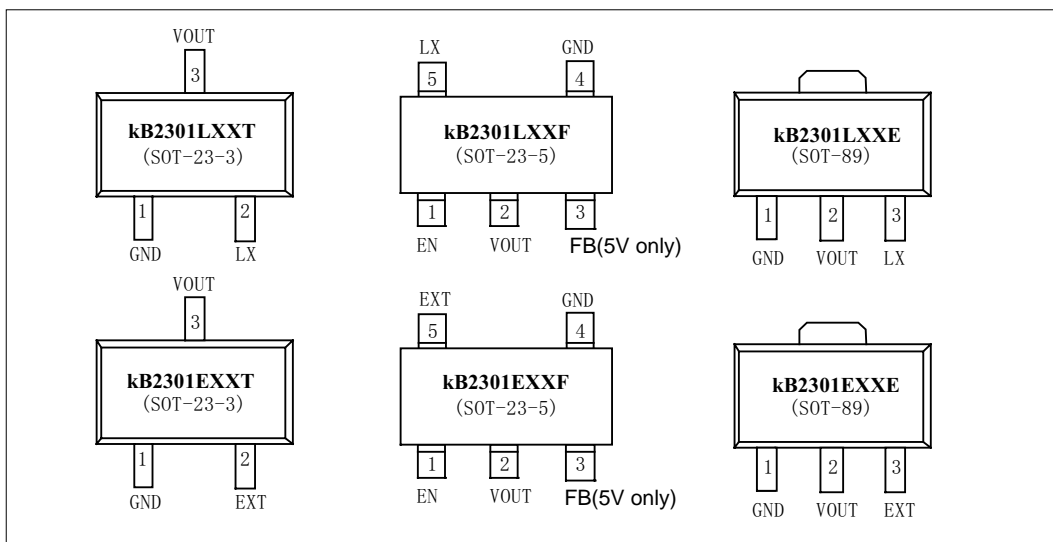



Absolute Maximum Ratings

Type	Symbol	Description	Value	Unit
Voltage	Vmax	Maximum voltage on VOUT and VLX pins	8	V
	Vmin-max	Voltage range on EXT and EN pins	-0.3-VOUT+0.3	V
Current	ILXmax	Maximum current on LX pin	1000	mA
	IEXTmax	Maximum current on EXT pin	100	mA
Power dissipation	P _{sot-23-3}	Maximum Power dissipation for SOT-23-3 package	0.25	W
	P _{sot-23-5}	Maximum Power dissipation for SOT-23-5 package	0.25	W
	P _{sot-89}	Maximum Power dissipation for SOT-89 package	0.5	W
Thermal	Tmin-max	Operation temperature range	-20-85	°C
	Tstorage	Storage temperature range	-40-165	°C
ESD	VESD	ESD voltage for human body mode	2000	V

Electronic Characteristics

Parameter	Symbol	Test Condition	Min	Typ	Max	Unit
Output voltage accuracy	ΔV_{OUT}		-2		2	%
Maximum input voltage	V _{INMAX}		0.7		VOUT	V
Start-up voltage	V _{START}	ILOAD=1mA, VIN:0→2V			0.85	V
Hold-on voltage	V _{HOLD}	ILOAD=1mA, VIN:2→0V	0.6			V
Maximum oscillation frequency	F _{MAX}		350	400	450	KHz
Oscillator duty cycle	DC _{OSC}		75	80	85	%
Efficiency	η			85	88	%
Current limit	I _{LIMIT}		600	800	1000	mA
Input current at no load	I _{IN0}	VIN=1.8V VOUT=3.0V		20		uA
		VIN=1.8V VOUT=5.0V				uA
VOUT pin current at switch off	I _{IOUT0}	Drive VOUT pin with voltage VOUT+0.5V		6	8	uA
Input standby current	I _{INQ}	No load, EN="low"			1	uA



EN “High” voltage level			0.4*VOU T			V
EN “low” level					0.2	V
EN “high” input current					0.1	uA
EN “low” input current			-0.1			uA
EXT output current			-5		5	mA

EEPW 电子產品世界
.com.cn



Typical Characteristics (Using Internal Switch Transistor)

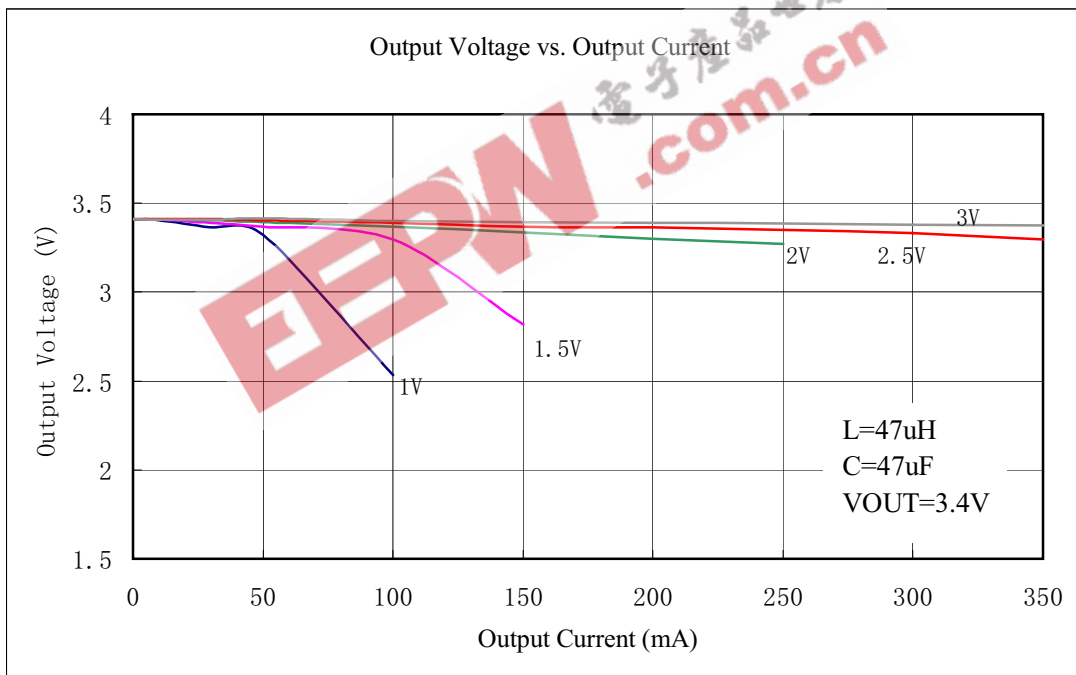
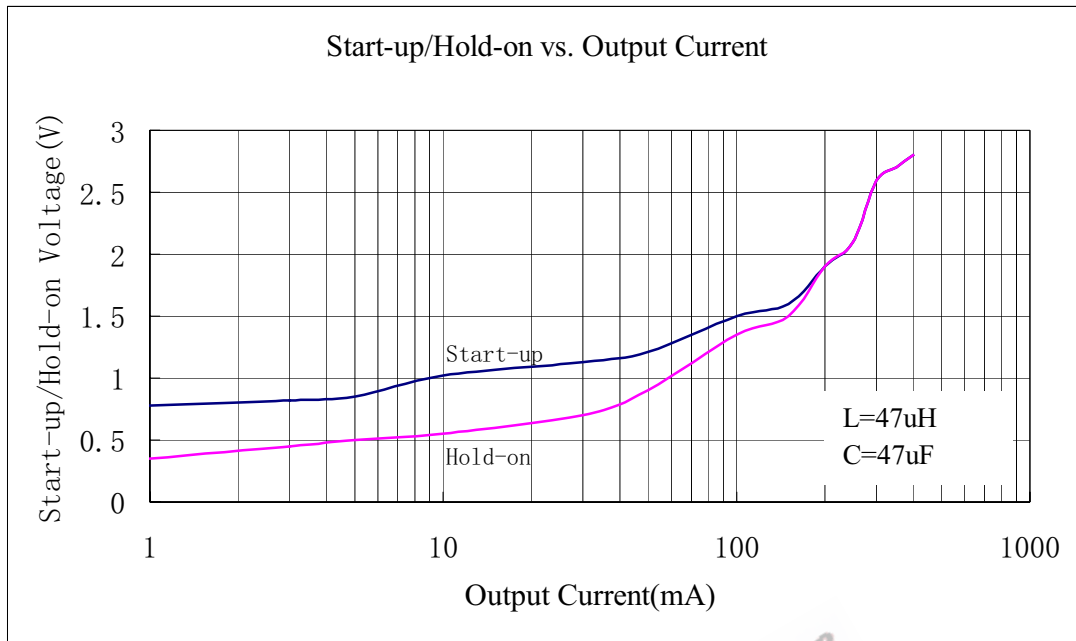

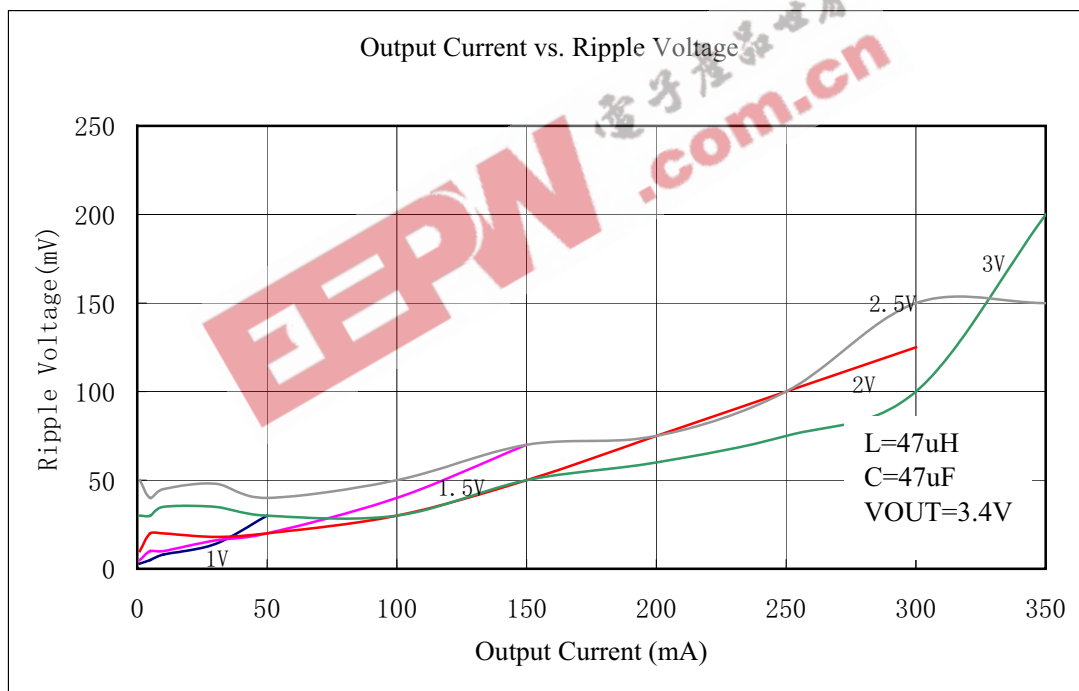
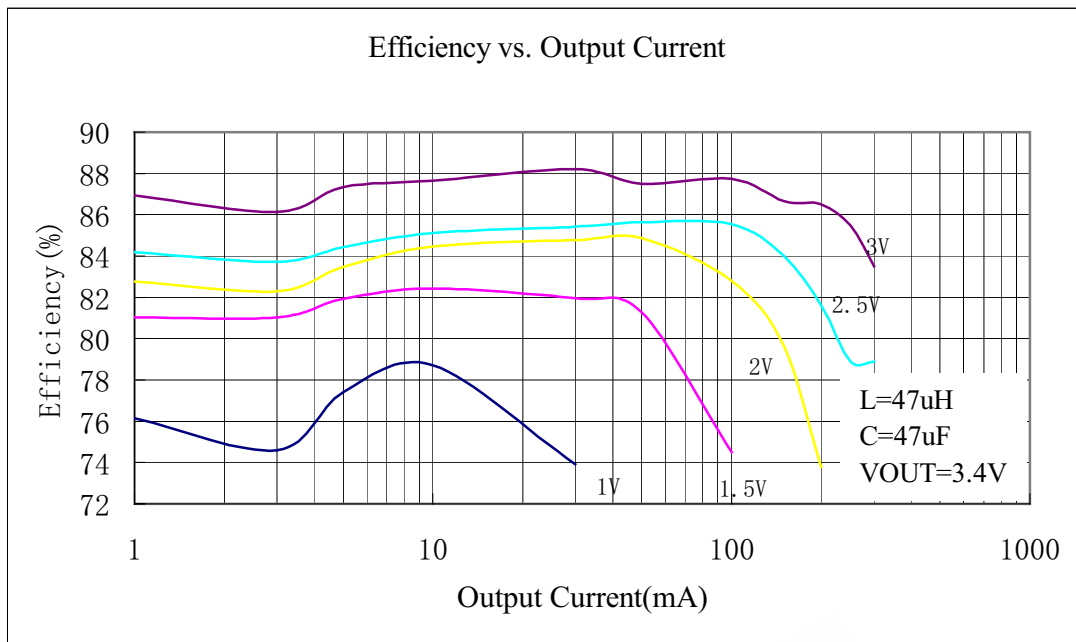

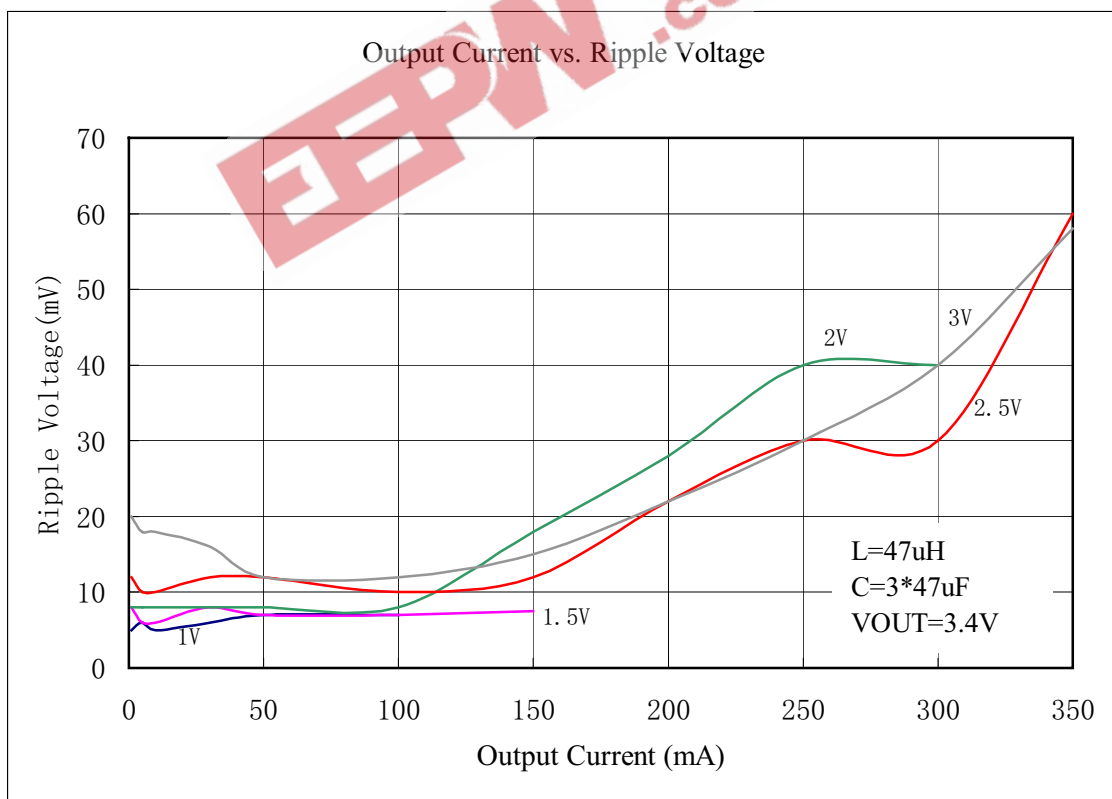
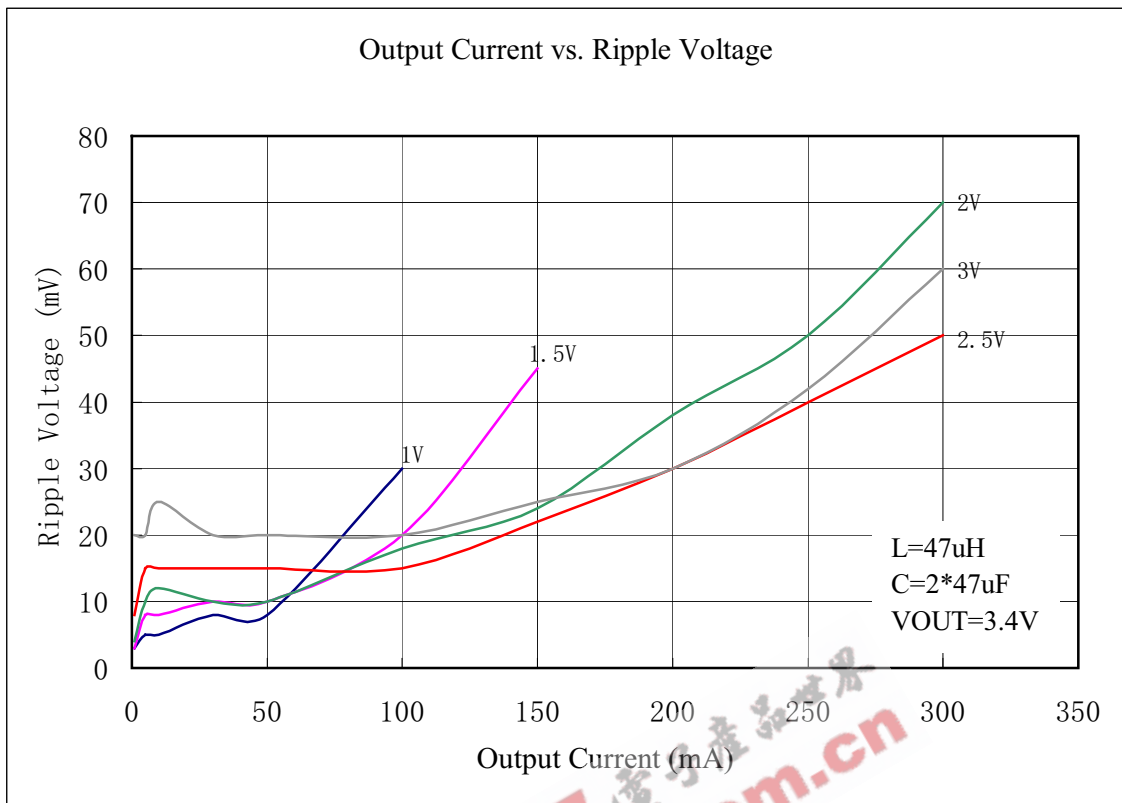



Package Information

SOT-23-3L PACKAGE OUTLINE DIMENSIONS

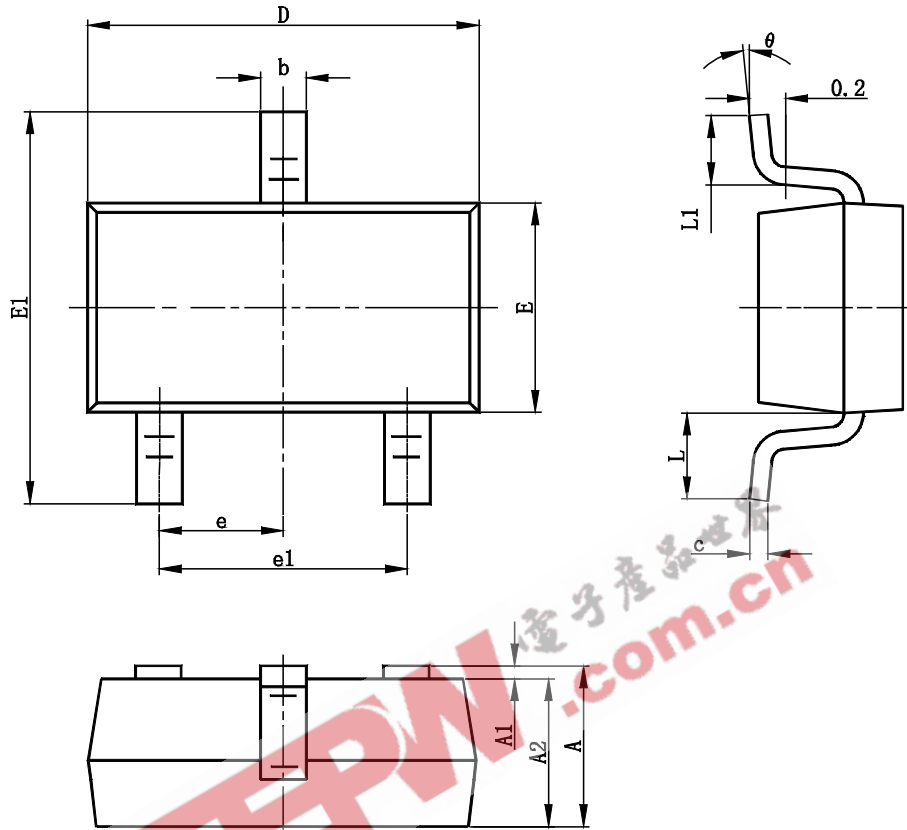

Symbol	Dimensions In Millimeters		Dimensions In Inches	
	Min	Max	Min	Max
A	1.050	1.250	0.041	0.049
A1	0.000	0.100	0.000	0.004
A2	1.050	1.150	0.041	0.045
B	0.300	0.400	0.012	0.016
c	0.100	0.200	0.004	0.008
D	2.820	3.020	0.111	0.119
E	1.500	1.700	0.059	0.067
E1	2.650	2.950	0.104	0.116
e	0.950TYP		0.037TYP	
e1	1.800	2.000	0.071	0.079
L	0.700REF		0.028REF	
L1	0.300	0.600	0.012	0.024
?	08	0	8	



SOT-23-5L PACKAGE OUTLINE DIMENSIONS

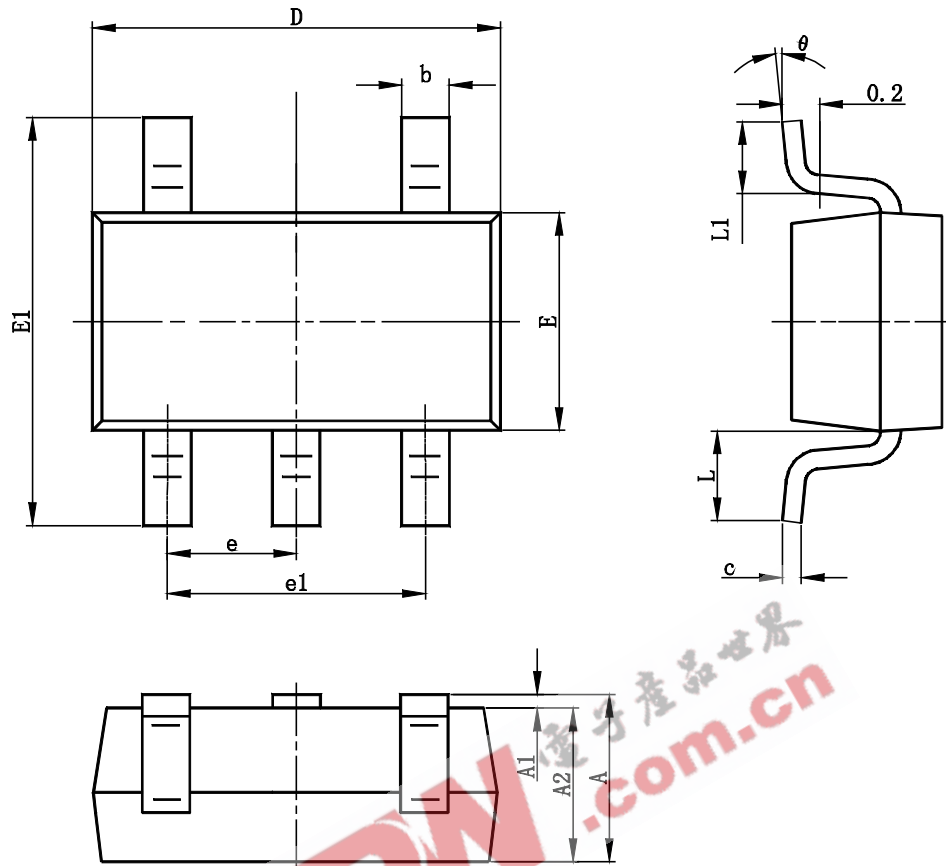

Symbol	Dimensions In Millimeter		Dimensions In Inches	
	Min	Max	Min	Max
A	1.050	1.250	0.041	0.049
A1	0.000	0.100	0.000	0.004
A2	1.050	1.150	0.041	0.045
b	0.300	0.400	0.012	0.016
c	0.100	0.200	0.004	0.008
D	2.820	3.020	0.111	0.119
E	1.500	1.700	0.059	0.067
E1	2.650	2.950	0.104	0.116
e	0.950TYP		0.037TYP	
e1	1.800	2.000	0.071	0.079
L	0.700REF		0.028REF	
L1	0.300	0.600	0.012	0.024
?	08	0	8	



SOT-89-3L PACKAGE OUTLINE DIMENSIONS

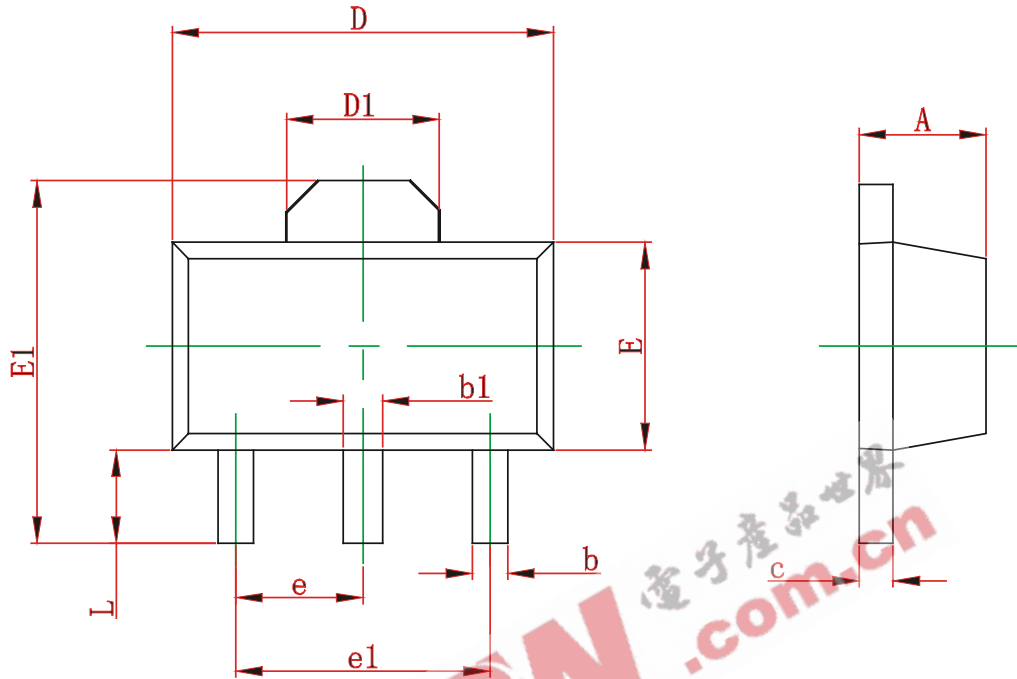

Symbol	Dimensions In Millimeter		Dimensions In Inches	
	Min	Max	Min	Max
A	1.400	1.600	0.055	0.063
b	0.320	0.520	0.013	0.197
b1	0.400	0.580	0.016	0.023
c	0.350	0.440	0.014	0.017
D	4.400	4.600	0.173	0.181
D1	1.550 REF		0.061 REF	
E	2.300	2.600	0.091	0.102
E1	3.940	4.250	0.155	0.167
e	1.500 TYP		0.060TYP	
e1	3.000 TYP		0.118TYP	
L	0.900	1.200	0.035	0.047