

KA9258D

MOTOR DRIVER

INTRODUCTION

The KA9258D is a quad power operational amplifier to drive spindle motor, sled motor, focus actuator and tracking actuator.

FEATURES

- 4-channel BTL driver
- Built in 5V regulator
- Built-in thermal shut down circuit
- Operating supply voltage: 6 ~ 13V

28-SSOPH-375

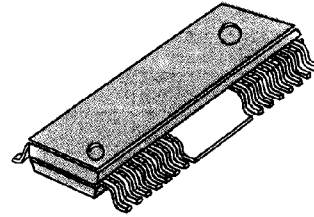

ORDERING INFORMATION

Device	Package	Operating Temperature
KA9258D	28-SSOPH-375	-25°C ~ +75°C

BLOCK DIAGRAM

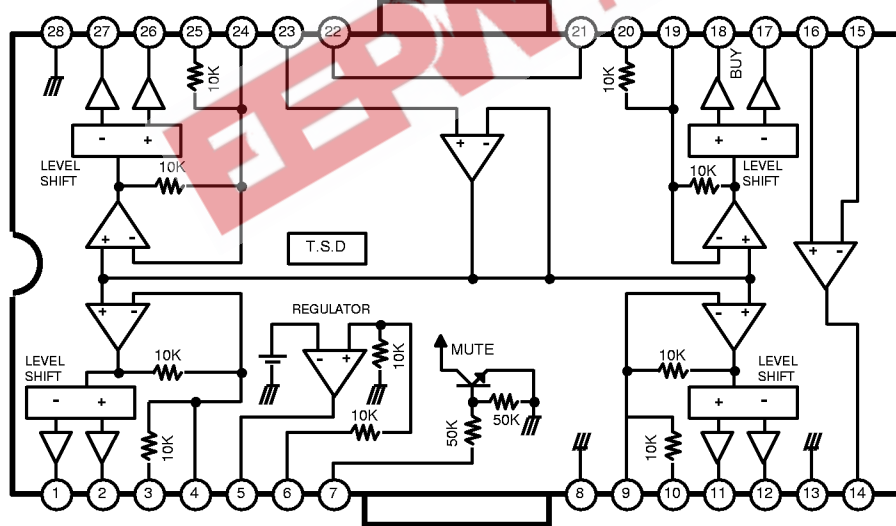

Fig. 1

PIN DESCRIPTION

Pin No.	Symbol	I/O	Description
1	DO1.1	O	DRIVE OUTPUT
2	DO1.2	O	DRIVE OUTPUT
3	DI1.1	I	DRIVE INPUT
4	DI1.2	I	DRIVE INPUT
5	REG		REGULATOR
6	REGO	O	REGULATOR OUTPUT
7	MUTE	I	MUTE
8	GND1	-	GROUND
9	DI2.1	I	DRIVE INPUT
10	DI2.2	I	DRIVE INPUT
11	DO2.1	O	DRIVE OUTPUT
12	DO2.2	O	DRIVE OUTPUT
13	GND2	-	GROUND
14	OPOUT	O	OPAMP OUTPUT
15	OPIN (-)	I	OPAMP INPUT (-)
16	OPIN (+)	I	OPAMP INPUT (+)
17	DO3.1	O	DRIVE OUTPUT
18	DO3.2	O	DRIVE OUTPUT
19	DI3.1	I	DRIVE INPUT
20	DI3.2	I	DRIVE INPUT
21	VCC1	-	SUPPLY VOLTAGE
22	VCC2	-	SUPPLY VOLTAGE
23	VREF	I	2.5V BIAS VOLTAGE
24	DI4.1	I	DRIVE INPUT
25	DI4.2	I	DRIVE INPUT
26	DO4.1	O	DRIVE OUTPUT
27	DO4.2	O	DRIVE OUTPUT
28	GND3	-	GROUND

KA9258D**MOTOR DRIVER****ABSOLUTE MAXIMUM RATINGS (Ta = 25 °C)**

Characteristic	Symbol	Value	Unit
Supply Voltage	V _{CC}	18	V
Power Dissipation	P _D	1.7	W
Operating Temperature	T _{OPR}	-25 ~ + 75	°C
Storage Temperature	T _{STG}	-55 ~ + 150	°C

(NOTE) Power Dissipation value: at V_{CC} = 8V.

ELECTRICAL CHARACTERISTICS

(Ta = 25°C, V_{CC} = 8V, Unless Otherwise Specified)

A. REGULATOR PART

Characteristic	Symbol	Test Conditions	Min	Typ	Max	Unit
Regulator Output Voltage	V _{REG}	I _L = 100mA	4.75	5	5.25	V
Load Regulation	ΔV _{RL}	I _L = 0mA to 200mA	-40.0	0	10.0	mV
Line Regulation	ΔV _{CC}	I _L = 200mA, V _{CC} = 6 to 9V	-10.0	0	20.0	mV

B. DRIVER PART

Characteristic	Symbol	Test Conditions	Min	Typ	Max	Unit
Quiescent Circuit Current	I _{CCQ}	V _I = 0	5.5	9.5	13.5	mA
Input Bias Current	I _{BOP}	V _I = 0			300	nA
Input offset voltage	V _{OFP}		-5.0	0	5.0	mV
Output offset voltage	V _{OO}		-3.0	0	30	
Maximum Sink Current	I _{SINK}	RL = 4ohm, V _{CC}	0.5	0.8		A
Maximum Source Current	I _{SOURCE}	RL = 4ohm, GND	0.5	0.8		
Maximum Output Voltage	V _{MA}	V _I = 2V _{rms} , 1KHz	2.5	3.0		V _{rms}
Closed loop Voltage Gain	A _{VF}	V _I = 0.1V _{rms} , 1KHz	4.5	6.5	7.5	dB
Ripple Rejection Ratio	RR	V _I = -20dB, 120Hz	60.0	80.0		
Slew Rate	SR	100Hz, Squarewave	1.0	2.0		V/us

APPLICATION CIRCUIT

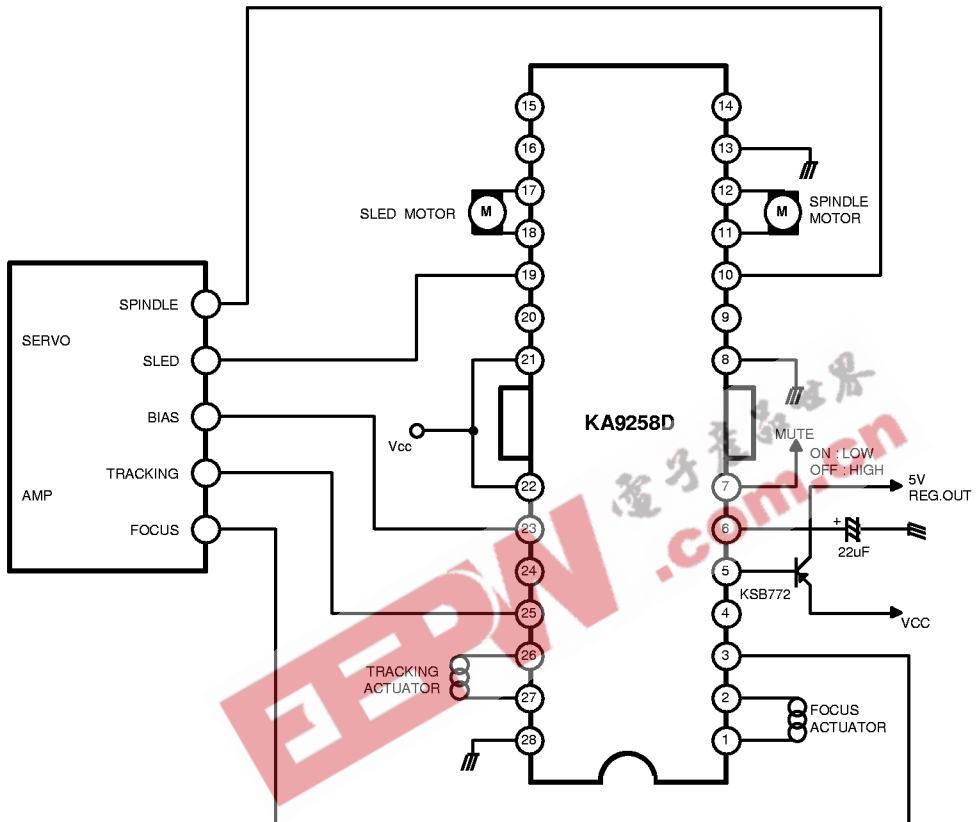

* THERMAL SHUT DOWN CIRCUIT

The IC is broken down by the heat when overload condition continue for a long time. So KA9258D have thermal shut down circuit to prevent this case. At that time the temperature of IC rise over 175 °C, the circuit is operating and protect the IC against breakdown.

28-SSOPH-375

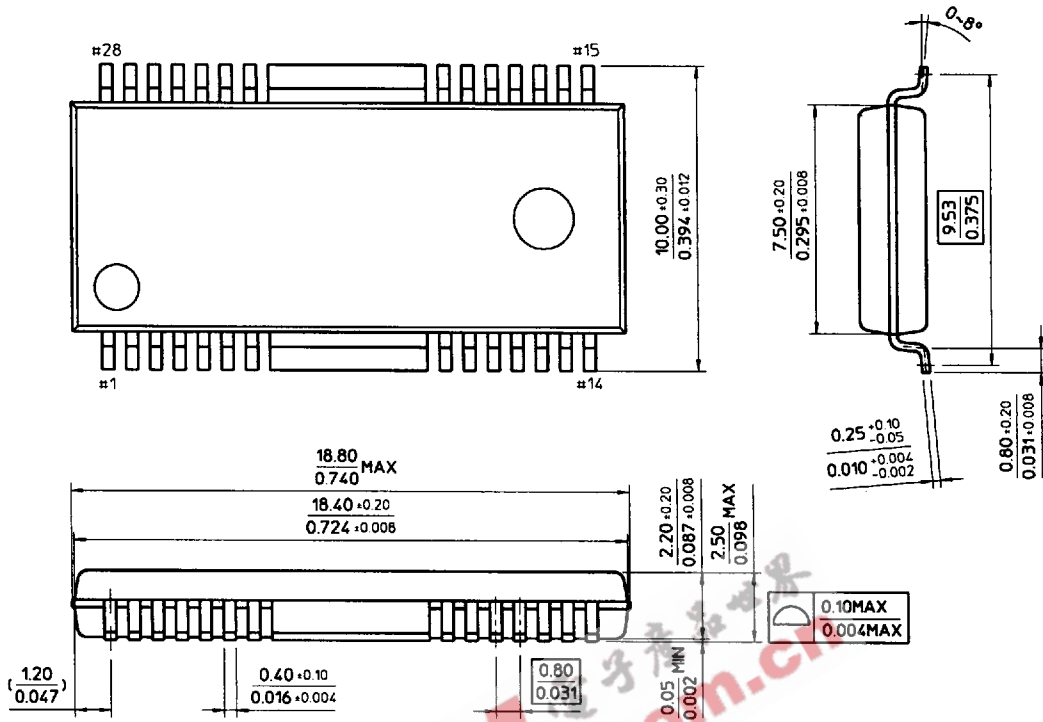

48-TSSOP-BD61

