



OFFLINE FLYBACK CONVERTERS DESIGN
METHODOLOGY WITH THE L6590 FAMILY

by Claudio Adragna

The design of flyback converters is quite a demanding task that requires SMPS engineers to cope with several problem areas such as magnetics, control loop analysis, power devices, as well as regulations concerning safety, EMC and the emerging standby consumption requirements. Lots of variable are involved and complex tradeoffs are necessary to meet the goal.

In this scenario, the high-voltage monolithic switchers of the L6590 family greatly simplify the task and, at the same time, allow to build robust and cost-effective low-power systems.

In this application note, after a review of flyback topology, a step-by-step design procedure of an offline single-output flyback converter will be outlined. As an example, the design of the test board will be carried out in details.

1 FLYBACK BASICS

Flyback operation will be illustrated with reference to the basic circuit and the waveforms of fig. 1. It is a two-step process. During the ON-time of the switch, energy is taken from the input and stored in the primary winding of the flyback transformer (actually, two coupled inductors). At the secondary side, the catch diode is reverse-biased, thus the load is being supplied by the energy stored in the output bulk capacitor.

Figure 1. Flyback Topology and associated waveforms.

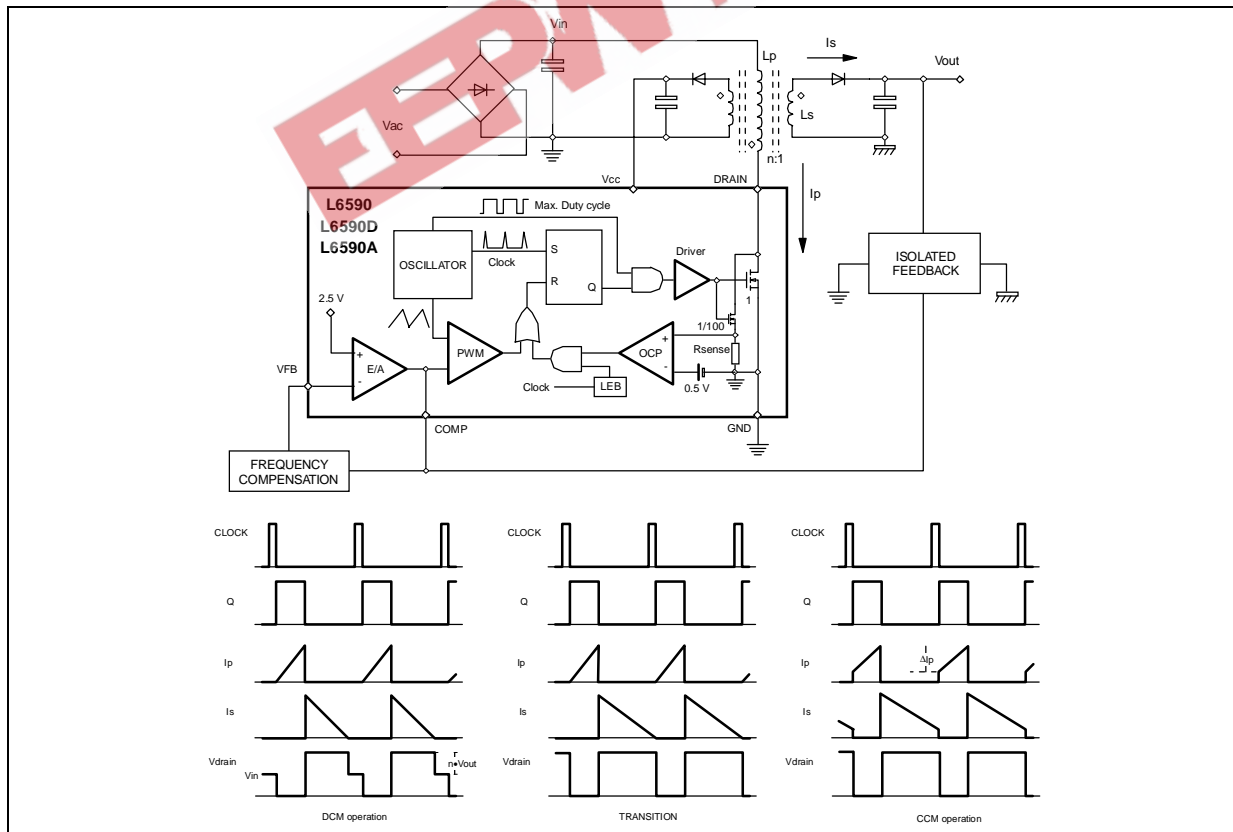

AN1262 APPLICATION NOTE

When the switch turns off, the primary circuit is open and the energy stored in the primary is transferred to the secondary by magnetic coupling. The catch diode is forward-biased, and the stored energy is delivered to the output capacitor and the load. The output voltage V_{out} is reflected back to the primary through the turns ratio n (V_R , reflected voltage) and adds up to the input voltage V_{in} , giving origin to a much higher voltage on the drain of the MOSFET.

Flyback is operated in DCM (Discontinuous Conduction Mode) when the input -or primary - current starts from zero at the beginning of each switching cycle. This happens because the secondary of the transformer has discharged all the energy stored in the previous period. If this energy transfer is not complete, the primary current will start from a value greater than zero at the beginning of each cycle. Then flyback is said to be operated in CCM (Continuous Conduction Mode). DCM is characterized by currents shaped in a triangular fashion, whereas CCM features trapezoidal currents.

The boundary between these two types of operation depends on several parameters. For a given converter, that is, as the switching frequency, inductance of the primary winding, transformer turns ratio and regulated output voltage are defined, it depends on the input voltage and the output load.

At design time, whether the converter will be operated in CCM or in DCM and where the boundary will be located is up to the designer. Usually CCM is selected with the objective of maximizing converter's power capability or minimizing primary RMS current. However, in CCM operation the system's dynamic behavior is considerably worse.

Usually, the converters based on the L6590 family devices are able to deliver the desired output power even with DCM operation, thus CCM will not be considered.

Table 1. Converter specification data and pre-design choices

Converter Electrical Specification	
V_{ACmin}	Minimum mains voltage
V_{ACmax}	Maximum mains voltage
f_L	Mains frequency (@ min. mains)
N_H	Number of holdup cycles
V_{out}	Regulated output voltage
$\Delta V_{out}\%$	Percent output voltage tolerance (\pm)
$V_r\%$	Percent output voltage ripple
P_{outmax}	Maximum output power
η	Expected converter efficiency
T_{amb}	Maximum ambient temperature
Pre-design Choices	
V_R	Reflected voltage
η_T	Transformer efficiency
V_{spike}	Leakage inductance overvoltage
V_{cc}	IC supply voltage
V_F	Secondary diode forward drop
V_{BF}	Bridge Rectifier + EMI filter voltage drop

2 CONVERTER ELECTRICAL SPECIFICATION

The starting point of the design procedure is the properties of the converter as a black-box, that is the set of data listed in the electrical specification table (table 1). Additional requirements, such as efficiency at zero load or line/load regulation or maximum junction temperature, etc., can be added to that list and their impact will be considered where appropriate.

- **Mains Voltage: Range and Frequency.** There are basically the three possible options listed in table 2, where a variation of $\pm 20\%$ is assumed, according to common practice. There are exceptions like some distribution lines rated at 277 V_{AC}, where a $\pm 10\%$ spread can be considered, or other special cases for specific applications. Table 2 shows also the line frequency to be considered in the standard cases at the minimum specified mains voltages. An additional specification may require the converter to be shut down if the mains voltage falls below a "brownout level". This additional specification will be used for setting up the brownout protection on the types where it is available.

Table 2. Mains voltage specifications

Input (V _{AC})	V _{ACmin} (V _{AC})	V _{ACmax} (V _{AC})	f _L (Hz)
110	88	132	60
220	176	264	50
WRM (Wide Range Mains)	88	264	60

- **Number of holdup cycles.** The holdup requirement is the ability of the converter to keep the output voltage in regulation even in case of mains interruption (missing cycles). This is usually specified in terms of number of mains cycles N_H. This feature is not always demanded (in which case, N_H = 0), otherwise the typical requirement is 1 mains cycle, that is N_H = 1. It impacts on the input bulk capacitor selection.
- **Output voltage tolerance.** It can be expressed either in absolute value or as a percentage of the nominal voltage. This requirement, as well as the ones on line and load regulation, if specified, will affect the choice of the feedback technique (primary or secondary).
- **Output voltage ripple.** The ripple superimposed on top of the DC output voltage is specified as the peak-to-peak amplitude and includes both low frequency (at 2·f_L) and high frequency (f_{sw}) component. Switching noise due to parasitics of the printed circuit board and random noise are beyond the scope of this procedure. This requirement, if tight, may require the use of an additional filtering cell at the output.
- **Converter Efficiency.** The efficiency is, by definition, the ratio of the output power to the input power. This figure is strongly dependent on the output voltage, because of the losses on the secondary diode. It should be set based on experience, using numbers of similar converters as a reference. As a rule of thumb, 75% ($\eta = 0.75$) can be used for a low voltage output (3.3 V or 5 V) and 80% ($\eta = 0.8$) for higher output voltages (12 V and above).

3 PRE-DESIGN CHOICES

Before starting the design calculations of the various parts of the converter, some parameters not defined at the "black-box level" need to be fixed. There is some degree of freedom in the selection of these parameters, provided some constraints are taken into account.

- **Reflected Voltage.** In principle, the reflected voltage should be as high as possible. In fact this leads to a greater duty cycle, which minimizes the RMS current through the IC's MOSFET for a given power throughput. There are two possible limitations to the maximum reflected voltage. One is the maximum duty cycle D_{max} allowed by the devices (67% min.); some margin should be considered for load transients, thus the reflected voltage should be such that the maximum duty cycle (at minimum input voltage

and maximum output power) does not exceed 62-64%. The other limitation is that the sum of the maximum input voltage, reflected voltage and overvoltage spike - due to the leakage inductance - must be below the breakdown of the internal MOSFET (700 V min.). Some margin needs also to be considered: at least 50V is recommended to take the forward recovery of the diode of the clamp circuit and parameter spread into account. Figure 2 illustrates schematically how the drain voltage is apportioned. The suggested value of V_R is 130 V: it leads to a maximum drain voltage slightly exceeding 500 V in 220V_{AC} or WRM applications, and about 320 V in 110 V_{AC} application, thus leaving enough room for an efficient leakage inductance demagnetization (see below). The maximum duty cycle will be about 60% in 110V_{AC} and WRM applications, and close to 36% in 220 V_{AC} applications.

Figure 2. Drain voltage composition.

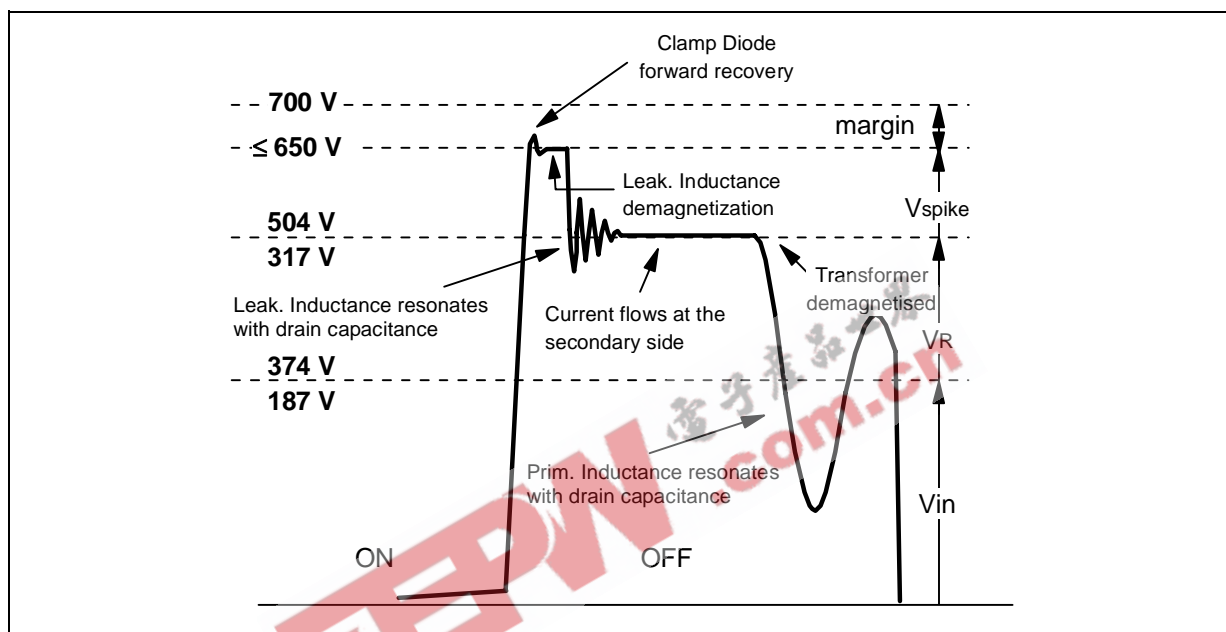

- **Leakage inductance overvoltage.** The energy stored in the mutual inductance of the transformer at the primary side is not completely transferred to the secondary, after MOSFET turn-off, until the leakage inductance is demagnetized. This delays and makes inefficient the energy transfer from primary to secondary. To minimize this noxious effect the voltage across the leakage inductance (the leakage inductance spike) that resets the inductance itself should be as high as possible. Obviously, this is limited by the maximum allowable drain voltage. With the reflected voltage selected as previously discussed, it is possible to allow about 140 V extra voltage in 220 V_{AC} or WRM applications and much more in 110 V_{AC} applications (see fig. 2). This will affect the design of the clamp circuit.
- **Transformer efficiency.** By definition, it is the ratio of the power delivered by the secondary winding to the power entering the primary. The secondary power includes the converter output power and the one dissipated in the secondary rectifier. Besides the secondary one, the primary power includes the one dissipated inside the transformer and that not transferred to the secondary side and dissipated on the leakage inductance. For typical transformers used in converters based on the L6590 family IC's, typical values of efficiency ranges between 88% and 95%, depending on the power level and on the construction technique. Efficiency increases with the power level and by using winding interleaving construction technique. For consistency, check that the input power of the transformer be less than the converter input power.
- **Device supply voltage.** The supply voltage range of the IC spans from 7 to 16.5 V. Such a wide range is envisaged to accommodate the variation that the voltage generated by the self-supply winding may

experience in converters with opto-isolated feedback. This variation is a result of the poor magnetic coupling with the secondary winding. It is then recommended to design the turns ratio of the self-supply winding so as to get a voltage approximately in the middle of this range (e.g. 11-12 V). This will give allowance for increasing at heavy load and dropping at zero load.

- **Secondary diode forward drop.** The type of secondary diode will be selected basically depending on the output voltage. In fact this determines the maximum reverse voltage applied to the diode while the MOSFET is switched on. For low output voltages ≤ 15 V) a Schottky diode can be used and a typical forward drop of 0.5V can be considered; for higher output voltages an ultrafast PN diode will be used, with a typical forward drop of 0.8 V.
- **Bridge Rectifier + EMI filter voltage drop.** This drop is subtracted to the peak of the input AC voltage and affects the peak voltage of the ripple superimposed on top of the DC voltage across the input bulk capacitor. A typical value can be 3 V.

4 PRELIMINARY CALCULATIONS (STEP 1)

There are a few quantities that need to be calculated before starting the individual design of each functional block of the converter. They are summarized in table 3.

Table 3. Preliminary calculations (step 1).

Symbol	Parameter	Definition
P_{in}	Converter Input Power	$P_{in} = \frac{P_{outmax}}{\eta}$
I_{out}	DC Output Current	$I_{out} = \frac{P_{outmax}}{V_{out}}$
V_{PKmin}	Minimum Peak Input Voltage	$V_{PKmin} = V_{ACmin} \cdot \sqrt{2} - V_{BF}$
V_{PKmax}	Maximum Peak Input Voltage	$V_{PKmax} = V_{ACmax} \cdot \sqrt{2}$

5 BRIDGE RECTIFIER SELECTION

Due to the limited power range that the device is able to handle, no special considerations are needed to select the diodes of the bridge rectifier. Any 1A rated standard diodes with 400/600 V reverse voltage are suitable. Some manufacturers make integrated bridge rectifiers housed in small packages. See table 4 for some suggested parts.

Table 4. 1A standard silicon rectifier and bridge selection

Type	Part Number	Rated Voltage	Package	Manufacturer(s)
Diode	1N4004	400	DO41	GI, GS, FAGOR, HTA, ON, TSC
Diode	1N4005	600	DO41	GI, GS, FAGOR, HTA, ON, TSC
Bridge	DF04M	400	DIL4	GI, TSC
Bridge	DF06M	600	DIL4	GI, TSC
Bridge	KBP104G	400	SIL4	TSC
Bridge	KBP105G	600	SIL4	TSC
Bridge	DFS04M	400	DIL4 (SMD)	HTA
Bridge	DFS06M	600	DIL4 (SMD)	HTA

6 INPUT BULK CAPACITOR SELECTION

The input bulk capacitor C_{in} , along with the bridge rectifier, converts the AC mains voltage to an unregulated DC bus, V_{in} , which is the input voltage for the downstream flyback converter. C_{in} must be large enough to have a relatively low ripple superimposed on top of the DC level, as shown in fig. 3. At minimum specified mains voltage, the value of C_{in} determines the absolute minimum, V_{inmin} , of the DC input voltage of the converter. The maximum duty cycle and the maximum peak current allowed by the IC must not be exceeded at this voltage. However, as to thermal consideration, the bus DC voltage (V_{DCmin} @ V_{ACmin}) should be considered.

Figure 3. Input voltage waveforms:
 a) without holdup capability;
 b) with holdup capability.

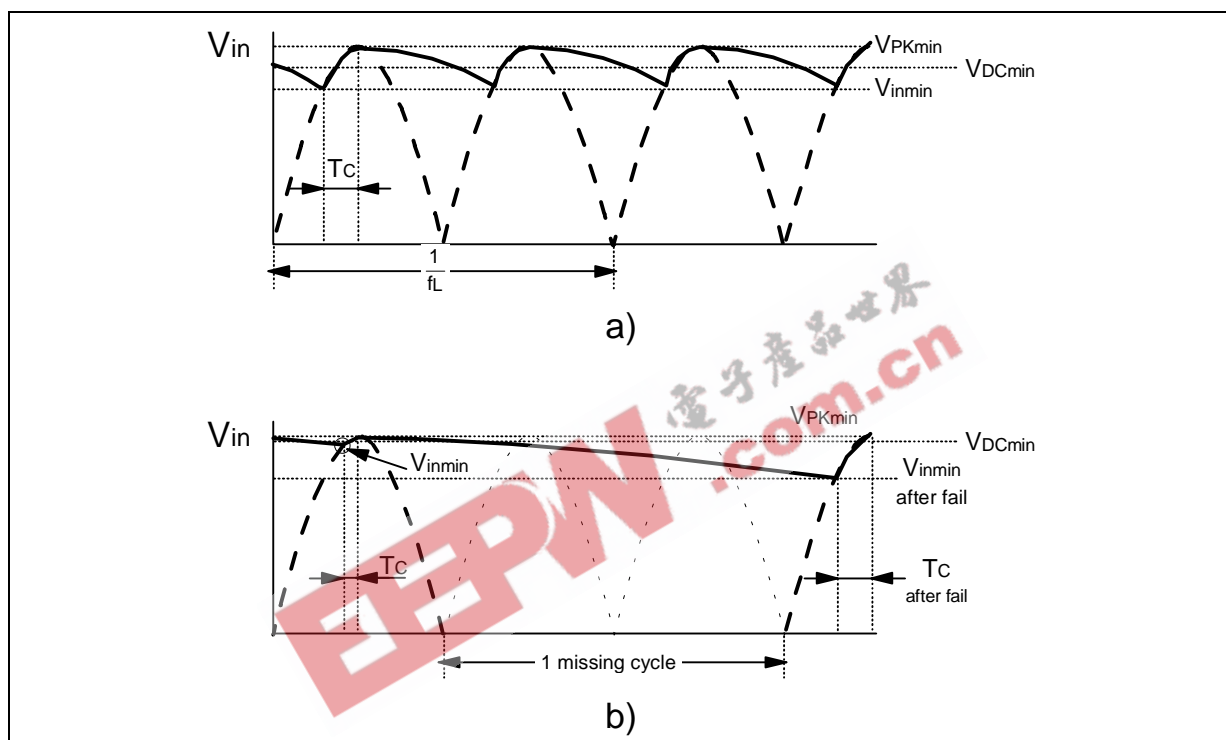

Large values of C_{in} result in higher V_{DCmin} and V_{inmin} , lower peak and RMS current through the power MOSFET (i.e. less power dissipation in the device) and less duty cycle range to achieve regulation but, on the other hand, also in bigger capacitor size, higher peak and RMS current drawn from the mains (i.e. more power dissipation in the bridge rectifier). Small values of C_{in} give origin to the opposite situation.

Experience shows that a good compromise between these contrasting requirements is a C_{in} value that causes the peak-to-peak ripple amplitude to be 25-30% of the peak mains voltage (@ V_{ACmin}), which means that V_{inmin} will be 70-75% of the peak value. Anyway, if holdup capability is required, a much larger capacitance values will be needed: the voltage ripple across C_{in} is expected to be 25-30% of the peak value, after 1 mains cycle missing, which means that in normal operation the ripple will be much less.

Table 5 summarizes the required capacitance per watt of input power for a given value of V_{inmin} , with and without holdup requirement, and shows the resulting values of V_{DCmin} . This allows to calculate the minimum capacitance needed, by multiplying the value taken from the table times P_{in} . Then a standard value will be selected, taking also the tolerance into account.

Table 5. Cin values for 1W input power

	110 VAC or WRM		220 VAC	
N _H =0	2.0 μF/W	3.0 μF/W	0.55 μF/W	0.8 μF/W
	V _{inmin} = 90V V _{DCmin} = 105V	V _{inmin} = 100V V _{DCmin} = 110V	V _{inmin} = 180V V _{DCmin} = 210V	V _{inmin} = 200V V _{DCmin} = 220V
N _H =1	7.2 μF/W	10.4 μF/W	1.8 μF/W	2.8 μF/W
	V _{inmin} = 90V V _{DCmin} = 116V	V _{inmin} = 100V V _{DCmin} = 117V	V _{inmin} = 180V V _{DCmin} = 236V	V _{inmin} = 200V V _{DCmin} = 239V

The actual values of V_{inmin} and V_{DCmin} need to be recalculated with the actual capacitance value. Since the evaluation of V_{inmin} involves an equation having no closed form solution, an iterative cycle needs to be established:

$$V_{inmin} = \sqrt{V_{PKmin}^2 - \frac{P_{in}}{C_{in}} \cdot \left(\frac{1 + 2 \cdot N_H}{f_L} - 2 \cdot T_c \right)}; T_c = \frac{\arccos\left(\frac{V_{inmin}}{V_{PKmin}}\right)}{2 \cdot \pi \cdot f_L} \quad (1)$$

where T_C is the recharging time of C_{in}, that is the time while the bridge diodes are conducting, which can be initially assumed equal to zero. After few iterations both V_{inmin} and T_C will converge to their respective values.

In case of holdup requirement the cycle should be executed twice. The first time with N_H = 1 to find V_{inmin} after one mains cycle missing (which will be used to check for maximum duty cycle and maximum peak current) the second one with N_H = 0 to find V_{inmin} in normal operation (to be used for steady state and thermal calculations).

V_{DCmin} will be simply the average of V_{inmin} (calculated with N_H = 0 anyway) and V_{PKmin}:

$$V_{DCmin} = \frac{1}{2} \cdot (V_{PKmin} + V_{inmin}) \quad (2)$$

The voltage rating of C_{in} is selected depending on V_{PKmax}: it is usually 200 V for 110 VAC applications and 400V for 220 VAC or WRM applications.

7 PRELIMINARY CALCULATIONS (STEP 2)

The next step is to check for not exceeding the limits imposed by the IC. Prior to this, the power processed by the transformer (P_{inT}) and the average voltage drop across the ON-resistance of the internal MOSFET (V_{DS(on)x}) will be evaluated. V_{DS(on)x} is subtracted to V_{inmin} and the resulting value is the voltage actually applied to the primary winding of the transformer. The R_{DS(on)} used must take temperature into account. Use the maximum value defined at 125°C.

The first limit to be checked is the maximum duty cycle D_X. If it exceeds 62-64%, either the reflected voltage V_R should be lowered or the minimum input DC voltage V_{inmin} should be increased by selecting a larger input capacitance.

The second limit to be checked is the maximum drain voltage during the OFF-state of the MOSFET. At least 50V margin should be ensured. The overvoltage spike can be reduced to allow more reflected voltage if necessary, keeping in mind that it cannot be much lower than V_R not to hurt the primary-to-secondary energy transfer.

The last check concerns the peak primary current that must not exceed the minimum guaranteed OCP threshold (0.55A). If this is exceeded, a higher maximum duty cycle D_X should be used, if possible. Also a higher V_{inmin} is beneficial. Some iterations, involving a recheck of the first two points, may be necessary to find the optimum compromise. If no solution can be found, either CCM operation should be considered or the power handled by the converter should be derated.

AN1262 APPLICATION NOTE

All of the above mentioned calculation steps are summarized in table 6.

Table 6. Preliminary Calculations (step 2)

Symbol	Parameter	Definition
P_{inT}	Transformer Input Power	$P_{inT} = \frac{(V_{out} + V_F) \cdot I_{out}}{\eta_T}$
$V_{DS(on)x}$	Max. average drop on $R_{DS(on)}$ in ON-state	$V_{DS(on)} \approx \frac{V_{inmin} + V_R}{1 + \frac{V_{inmin} \cdot V_R}{P_{in} \cdot R_{DS(on)}}}$
D_x	Maximum Duty Cycle	$D_x = \frac{V_R}{(V_{inmin} - V_{DS(on)x}) + V_R}$
V_{DSmax}	Maximum drain Voltage in OFF-state	$V_{DSmax} = V_{PKmax} + V_R + V_{spike}$
$I_{p_{pkx}}$	Max. Peak Primary Current	$I_{p_{pkx}} = \frac{P_{inT}}{V_{inmin} - V_{DS(on)x}} \cdot \frac{2}{D_x}$

8 OPERATING CONDITIONS @ $V_{in} = V_{DCmin}$

From the thermal point of view the heaviest operating conditions for the IC, and for most of the other parts of the converter as well, are usually encountered at minimum input voltage.

That is why the operating conditions @ $V_{in} = V_{DCmin}$ need being evaluated. This will be done with the aid of the relationships in table 7.

Table 7. Relationship useful for calculating converter's operating conditions @ $V_{in} = V_{DCmin}$

Symbol	Description	Definition
D	Duty Cycle (switch ON-time to switching period ratio)	$D = \frac{V_{inmin} - V_{DS(on)x}}{V_{DCmin} - V_{DS(on)x}} \cdot D_x$
$I_{p_{pk}}$	Peak Primary Current	$I_{p_{pk}} = I_{p_{pkx}}$
$I_{p_{DC}}$	DC Primary Current	$I_{p_{DC}} = \frac{D \cdot I_{p_{pk}}}{2}$
$I_{p_{RMS}}$	Total RMS Primary Current	$I_{p_{RMS}} = I_{p_{pk}} \cdot \sqrt{\frac{D}{3}}$
$I_{p_{AC}}$	RMS Primary Current (AC component only)	$I_{p_{AC}} = \sqrt{I_{p_{RMS}}^2 - I_{p_{DC}}^2}$
D'	Secondary diode conduction time to switching period ratio	$D' = \frac{V_{DCmin} - V_{DS(on)x}}{V_R} \cdot D$
$I_{s_{pk}}$	Peak Secondary Current	$I_{s_{pk}} = \frac{2 \cdot I_{out}}{D'}$
$I_{s_{DC}}$	DC Secondary Current	$I_{s_{DC}} = I_{out}$

Table 7. (continued)

Symbol	Description	Definition
I _{RMS}	Total RMS Secondary Current	$I_{RMS} = I_{Spk} \cdot \sqrt{\frac{D'}{3}}$
I _{SAC}	RMS Secondary Current (AC component only)	$I_{SAC} = \sqrt{I_{RMS}^2 - I_{DC}^2}$

Once this information has been found, it is possible to evaluate the power dissipation of the IC and check for thermal limitations. Table 8 summarizes the relationships that can be used for this evaluation. In those formulae:

- T_c is the crossover time of the voltage and current waveforms at MOSFET's turn off;
- C_{drain} is the total capacitance of the drain, composed of the C_{oss} of the MOSFET, the parasitic capacitance of the primary winding and, in case, some external capacitance.

As previously said, the worst-case operating conditions for the IC usually occur at V_{in} = V_{DCmin}, however it is worthwhile checking the losses also at maximum input voltage, that is at V_{in} = V_{PKmax}, especially if an external capacitor is added on the drain.

With the worst-case total losses in the IC it is possible to find the maximum junction-to-ambient thermal resistance allowed for safe operation at maximum ambient temperature.

The operating temperature range of the devices extends to 150 °C, however designing for such high temperature is not recommended. A reasonable target can be to design for 125 °C maximum die temperature:

$$R_{thmax} = \frac{125 - T_{amb}}{P_Q + P_{cond} + P_{sw} + P_{cap}} \quad (3)$$

Table 8. IC's power losses estimate

Symbol	Description	Definition
P _{cond}	Conduction losses	$P_{cond} = I_{pRMS}^2 \cdot R_{DS(on)max}$
P _{sw}	Switching losses	$P_{sw} \approx \frac{1}{3} \cdot (V_{in} + V_R) \cdot I_{pPk} \cdot T_c \cdot f_{sw}$
P _{CAP}	Capacitive losses	$P_{CAP} \approx \frac{1}{2} \cdot C_{drain} \cdot (V_{in} + V_R)^2 \cdot f_{sw}$
P _Q	Quiescent losses	$P_Q = V_{CC} \cdot I_{op}$
Assume: R _{DS(on) max} = 28 Ω (@ T _j = 125 °C) T _c = 50ns f _{sw} = 65kHz C _{drain} = 100pF I _{op} = 7mA		

With the aid of the diagrams shown in fig. 20 it is possible to estimate whether the required thermal resistance is feasible or not and, in the positive case, how large the on-board copper area is supposed to be. Consider that copper areas larger than 4 cm² do not give significant reduction of thermal resistance and may cause PCB layouting to become a serious issue.

If the thermal check does not give positive results, a different heatsinking strategy may be considered, otherwise a higher maximum duty cycle D_x should be used, if possible, to reduce the RMS current. Also a higher V_{inmin}

AN1262 APPLICATION NOTE

(that is a larger input capacitor) is of help. Some iterations, involving a recheck of the points mentioned in "Preliminary Calculations - step 2", may be necessary.

If no solution can be found, either some specification should be relaxed or the power handled by the converter should be derated.

9 FLYBACK TRANSFORMER DESIGN

To complete the set of data needed to design the flyback transformer, the primary inductance value (L_p) and the primary-to-secondary turns ratio (n) are still to be defined.

The primary inductance will be chosen so that the converter is operated on the boundary between DCM and CCM at $V_{in} = V_{inmin}$:

$$L_p = \frac{[(V_{inmin} - V_{DS(on)X}) \cdot D_X]^2}{2 \cdot f_{sw} \cdot P_{inT}} \quad (4)$$

while the primary-to-secondary turns ratio is defined so as to get the desired reflected voltage V_R :

$$n = \frac{V_R}{V_{out} + V_F} \quad (5)$$

With the complete set of specification, the transformer design can start with the selection of the magnetic core material and geometry.

Table 9. Ferrite Materials selection

Grade	Saturation flux density [T]	Specific Power Losses @ 100 °C [W/cm ³]	Manufacturer
B2	0.36	$\bar{P}_{Fe} = 1.15 \cdot 10^{-5} \cdot \Delta B^{2.26} \cdot f_{sw}^{1.11}$	THOMSON
3C85	0.33	$\bar{P}_{Fe} = 1.54 \cdot 10^{-7} \cdot \Delta B^{2.62} \cdot f_{sw}^{1.54}$	PHILIPS
N67	0.38	$\bar{P}_{Fe} = 8.53 \cdot 10^{-7} \cdot \Delta B^{2.54} \cdot f_{sw}^{1.36}$	EPCOS (ex S+M)
PC30	0.39	$\bar{P}_{Fe} = 1.59 \cdot 10^{-6} \cdot \Delta B^{2.58} \cdot f_{sw}^{1.32}$	TDK
F44	0.4	$\bar{P}_{Fe} = 2.39 \cdot 10^{-6} \cdot \Delta B^{2.23} \cdot f_{sw}^{1.26}$	MMG

As to the magnetic material, a standard soft ferrite for power applications (gapped core-set with bobbin) is the usual choice: the switching frequency is not so high thus special grades for high frequency operation are not required. Table 9 shows some suitable materials.

The geometry will be usually a popular E or E-derived type. Other configurations, such as RM or PQ cores, are not recommended because they are inherently high leakage geometries, since they result in narrower and thicker windings. Consider that minimizing leakage inductance is one of the major tasks in the design of a flyback transformer.

Among the various shapes and styles offered by manufacturers the most suitable one will be selected with technical and economic considerations. Table 10 shows some possible choices with the relevant data useful for the design.

The next quantity to be defined is the peak flux density B_{max} which the transformer will be operated at. Being this a DCM design, B_{max} will also equal the maximum flux density swing ΔB_{max} .

Due to the moderate switching frequency, B_{max} will be limited by core saturation and not by core losses. This means that transformer's power losses will be located mostly in the windings.

As shown in table 9, ferrites saturate above 0.3 T thus a value of B_{max} equal to 0.28-0.30 T may be selected to maximize core utilization, or $B_{max} = 0.25$ T can be chosen for a more conservative design.

This maximum peak flux density will occur when the peak primary current is maximum. However, it is not sufficient to consider the peak current I_{pk} resulting from table 6. To guarantee that the transformer does not saturate even under short circuit conditions, the maximum peak primary current to be considered is the maximum value of the OCP threshold ($I_{lim} = 0.7A$, from the datasheet).

Now a step-by-step procedure for the design of the transformer will be given.

Table 10. Core list and significant design data

Core	Ve [cm ³]	Ae [cm ²]	Aw [cm ²]	AP [cm ⁴]	K1	K2	Lt [cm]	WB [cm]	Rth [°C/W]
THOMSON (B2)									
EF1505A	0.51	0.15	0.15	0.022	29.7	-0.68	2.63	0.92	75
EF2007A	1.46	0.31	0.26	0.081	61.1	-0.7	3.65	1.32	45
EF2509A	3.3	0.58	0.4	0.232	103	-0.73	4.64	1.64	30
E2006A	1.5	0.32	0.35	0.112	62.2	-0.7	3.9	1.18	46
E2507A	3.2	0.55	0.6	0.33	90	-0.73	5.2	1.54	40
PHILIPS (3C85)									
E16/8/5	0.75	0.201	0.216	0.043	42.2	-0.7	3.3	0.94	65
E20/10/6	1.49	0.32	0.35	0.112	62.2	-0.69	3.9	1.18	46
E25/13/7	2.99	0.52	0.56	0.291	90	-0.73	4.9	1.56	40
EPCOS (ex S+M) (N67)									
E16/8/5	0.76	0.2	0.22	0.044	42.2	-0.7	3.4	1	65
E20/10/6	1.49	0.32	0.34	0.109	62.2	-0.69	4.12	1.25	46
E25/13/7	3.02	0.52	0.61	0.317	90	-0.73	5	1.56	40
TDK (PC30)									
EI16-Z	0.67	0.198	0.267	0.053	66	-0.57	3.31	0.86	44
EI22-Z	1.63	0.42	0.2	0.084	85.4	-0.71	3.86	0.845	33
EI25-Z	1.93	0.41	0.425	0.174	119	-0.57	4.94	0.98	31
MMG - NEOSID (F44)									
EF16	0.754	0.225	0.216	0.049	42.2	-0.7	3.3	1	65
EF20	1.5	0.314	0.348	0.109	62.2	-0.69	3.9	1.2	46
EF25	3.02	0.515	0.564	0.29	90	-0.73	4.8	1.6	40

1) *Choose core size.* Transformer's core must be able to handle the power throughput P_{inT} without saturating and with acceptable power losses, with the minimum size. Determining its optimum size is a trial-and-error process and a proper starting point may reduce considerably the number of iterations needed.

A most common way of describing core size is the so-called Area Product (AP), which is the product of the effective cross-sectional area of the core times the window area available to accommodate the windings. It is possible to define the minimum AP required by a specific application.

The following equation can be useful to estimate the minimum AP (in cm⁴) required:

AN1262 APPLICATION NOTE

$$AP_{\min} = 10^3 \cdot \left(\frac{L_p \cdot I_{pRMS}}{\Delta T^2 \cdot K_u \cdot B_{\max}} \right)^{1.316} \quad [\text{cm}^4] \quad (6)$$

In this equation ΔT is the hot-spot temperature rise (located in the core center leg, where heat can be removed more difficultly), defined as $\Delta T = T_{\max} - T_{\text{amb}}$. For reliability reasons T_{\max} is usually limited at 100°C where, by the way, ferrites usually feature minimum losses. K_u is the window utilization factor, that is the portion of the total core window area occupied by the windings, which can be estimated equal to 0.4 for margin wound construction and to 0.7 for triple insulated wire construction.

The smallest core with an AP greater than AP_{\min} will be chosen from the catalog data (the core list of table 10 can be used as a reference). If there is a core with an $AP < AP_{\min}$ but very close to, it might be worthwhile trying to design with this smaller core before trying the larger one.

2) Calculate the required minimum number of primary turns of the primary winding. It will be given by:

$$N_{p_{\min}} = \frac{L_p \cdot 0.7}{B_{\max} \cdot A_e} \cdot 10^4$$

3) Define primary and secondary windings' turns number. In the case of single-output under consideration, the secondary winding turns number N_s will be simply:

$$N_s = \left[\frac{N_p}{n} + 1 \right],$$

that is, the result of the division will be rounded up to the next larger integer. The actual primary turns will then be calculated, rounding the result to the closest integer.

$$N_p = [N_s \cdot n + 0.5].$$

It can be convenient to round to the next even number when interleaved winding technique is to be used for transformer construction, so as to split the primary in two equal halves.

4) Calculate the air gap length. The gap length (l_g) needed to get the desired inductance L_p will be calculated with the following empirical formula:

$$l_g = \left(\frac{L_p}{N_p^2} \cdot \frac{10^9}{kT} \right)^{\frac{1}{k2}} \quad [\text{mm}] \quad (7)$$

If the calculated value is not available as a standard part, if possible, the primary turns number can be adjusted a little bit to get an off-the-shelf part.

The air gap should be located on the core center leg only, to minimize radiated fields. In prototyping, center leg grinding to get nonstandard gap values can be avoided by keeping the two half-cores apart by about half the calculated value with spacers.

5) Calculate transformer total losses. The allowed total transformer losses (P_{tot}) can be calculated by dividing the hot-spot temperature rise ΔT by the thermal resistance of the wound core $R_{\text{th(core)}}$:

$$P_{\text{tot}} = \frac{\Delta T}{R_{\text{th(core)}}} \quad [\text{W}]$$

If the manufacturer does not provide thermal data, $R_{\text{th(core)}}$ can be estimated. It has been shown [1] that there is a good correlation between core's area product and thermal resistance, regardless of its shape:

$$R_{\text{th(core)}} \approx 23 \cdot AP^{-0.37} \quad [^\circ\text{C/W}];$$

this best-fit equation refers to natural convection cooling.

- 6) Calculate the actual flux swing, the actual core losses and the allowed copper losses. The flux swing will be given by:

$$\Delta B = \frac{L_p \cdot I_{p_{pk}}}{N_p \cdot A_e} \cdot 10^4 \quad [\text{T}] \quad (8)$$

and the corresponding core losses can be calculated with the formulae in table 9:

$$P_{Fe} = V_e \cdot k \cdot \Delta B^p \cdot f_{sw}^q \quad [\text{W}] \quad (9)$$

The allowed copper losses will obviously be:

$$P_{Cu} = P_{tot} - P_{Fe} \quad [\text{W}] \quad (10)$$

- 7) *Design windings.* The goal is to find the right wire size so that copper losses are within the limit stated by (10). At this moment, losses due to skin and proximity effect will not be accounted for. The construction technique of the transformer will be such that these effects will be minimized.

Copper losses will be equally apportioned to the primary and the secondary winding (the power handled by the auxiliary one is negligible). Therefore the maximum primary and secondary winding resistance will be respectively:

$$R_p = \frac{P_{Cu}}{2 \cdot I_{p_{RMS}}^2} \quad [\Omega]; \quad R_s = \frac{P_{Cu}}{2 \cdot I_{s_{RMS}}^2} \quad [\Omega] \quad (11)$$

The primary and secondary conductor copper cross-section area will be obtained considering the resistivity of copper at 100°C ($\rho_{100} = 2.303 \cdot 10^{-6} \Omega \cdot \text{cm}$) and the average length-per-turn (4) of the bobbin associated to the selected core:

$$A_{p_{Cu_{min}}} = \frac{\rho_{100} \cdot N_p \cdot L_t}{R_p} \quad [\text{cm}^2] \quad (12)$$

$$A_{s_{Cu_{min}}} = \frac{\rho_{100} \cdot N_s \cdot L_t}{R_s} \quad [\text{cm}^2] \quad (13)$$

A wire table (like the sample one shown in table 11) will be looked up and a wire with a copper area ($A_{p_{Cu}}$, $A_{s_{Cu}}$) equal or greater than the minimum above calculated will be selected. Anyway, to minimize skin effect, the selected wire diameter should not exceed $2 \cdot \delta$, where δ is the skin depth of copper (about 0.3 mm at 65 kHz and 100°C). In practice, the maximum wire size for minimum skin effect is AWG23 ($\varnothing 0.57 \text{ mm}$, $A_{Cu} = 0.2573 \text{ mm}^2$). If $A_{p_{Cu}}$ is larger, a number (N_{wp} , N_{ws}) of such (or smaller) wires will be paralleled so as to achieve the desired total area:

$$N_{wp} = \frac{A_{p_{Cu_{min}}}}{A_{p_{Cu}}}$$

$$N_{ws} = \frac{A_{s_{Cu_{min}}}}{A_{s_{Cu}}}$$

where the results will be rounded up to the next larger integer.

Table 11. Wire Table (RS-214). Copper wire. Heavy insulation.

AWG	Diameter Copper [cm]	Diameter Insulated [cm]	Area Copper [cm ²]	Area Insulated [cm ²]
22	0.064	0.071	0.003255	0.004013
23	0.057	0.064	0.002582	0.003221
24	0.051	0.057	0.002047	0.002586
25	0.045	0.051	0.001624	0.002078
26	0.040	0.046	0.001287	0.001671
27	0.036	0.041	0.001021	0.001344
28	0.032	0.037	0.000810	0.001083
29	0.029	0.033	0.000642	0.000872
30	0.025	0.030	0.000509	0.000704
31	0.023	0.027	0.000404	0.000568
32	0.020	0.024	0.000320	0.000459
33	0.018	0.022	0.000254	0.000371

Finally the total winding area must be checked to make sure they fit the bobbin window A_w :

$$A_{pi} \cdot N_{wp} \cdot N_p + A_{si} \cdot N_{ws} \cdot N_s \leq K_u \cdot A_w \tag{14}$$

where A_{pi} and A_{si} are the individual wire cross-section, primary and secondary respectively, including isolation. If the above inequality is not verified there are the following options:

- a) if N_p is quite larger than N_{pmin} , try decreasing N_p and go back to step 3;
- b) choose a smaller wire, recalculate N_{wp} and N_{ws} and recheck window fitting;
- c) use fewer wires in a strand accepting a likely larger temperature rise;
- d) use the next size core and restart from step 2.

Finally, the auxiliary winding will be defined. It has not been considered before because it handles a very low power, thus it will be made with a single thin wire (e.g. AWG32 or AWG33) which gives a negligible contribution to winding build and losses. Just the turns number needs to be defined:

$$N_{aux} = N_s \cdot \frac{V_{CC} + 0.7}{V_{out} + V_F} \tag{15}$$

where 0.7 V is the typical forward drop on the auxiliary (small signal) diode.

8) Calculate actual power dissipation and hot-spot temperature rise. The actual resistance of the primary and secondary windings has to be calculated first:

$$R_p = \rho_{100} \cdot \frac{N_p \cdot L_t}{N_{wp} \cdot A_{pCu}} ; \quad R_s = \rho_{100} \cdot \frac{N_s \cdot L_t}{N_{ws} \cdot A_{sCu}} ,$$



then the total power dissipation and the hot spot temperature rise will be respectively:

$$P_{\text{tot}} = P_{\text{Fe}} + R_p \cdot I_{p_{\text{RMS}}}^2 + R_s \cdot I_{s_{\text{RMS}}}^2$$

$$\Delta T = P_{\text{tot}} \cdot R_{\text{th}}$$

Finally, some suggestions on the transformer construction techniques. When building a transformer, the general rule is to minimize parasitics, basically leakage inductance and winding capacitance.

In order for a transformer to meet isolation and safety norms, primary and secondary windings must be separated by isolation layers, thus their coupling cannot be intimate. Moreover, in a margin wound construction the entire window breadth cannot be used (2.5 to 3 mm margin on each side must be considered to achieve sufficient creepage distance) thus the winding becomes shorter and thicker, which hurts coupling. This is why triple insulation construction is recommended.

Figure 4. Interleaved winding technique

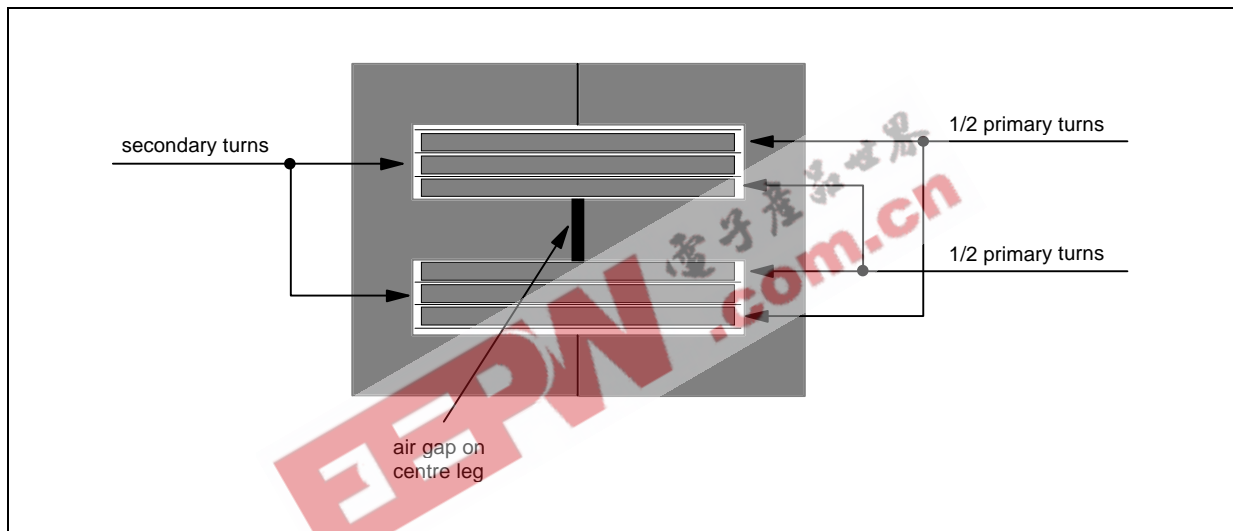

As a result, it is not possible to reduce leakage inductance below a certain extent. Practically, for a well assembled transformer, leakage inductance will be about 1 to 3% of the primary inductance.

Interleaved windings technique (putting on half the primary turns first, then the secondary and finally the other half of the primary, see fig. 4) may considerably reduce leakage inductance (theoretically almost four times). The two primary halves must be series connected, never paralleled. Other tricks, such as spacing windings evenly across a layer (when they do not completely fill it), or using multiple strands of wire, or keeping isolation between windings to a minimum are also effective. Besides, the use of split bobbins is not recommended.

Primary winding capacitance is the major component of the C_{drain} capacitance earlier mentioned. Besides contributing to internal MOSFET power losses, it causes ringing and noise problems that may force the use of additional damping networks to comply with EMC requirements.

To achieve a low capacitance, always wind first the primary winding and, in particular, the half whose end is to be connected to the drain of the MOSFET. In this way the second half primary has a shielding effect that reduces the capacitive coupling. In case of multiple layer windings, which exhibit higher capacitance, it is useful to embed one layer of isolation between two adjacent winding layers. This, however, tends to increase leakage inductance and therefore should be done with care.

10 CLAMP CIRCUIT DESIGN

The drain pin of the IC needs to be properly clamped to prevent the spike due to the transformer leakage inductance from exceeding the breakdown voltage (700V minimum). An RCD clamp (see fig. 5a) is a popular cheap solution, however it dissipates power even under no-load conditions: there is at least the reflected voltage V_R across the clamp resistor at all times. If minimizing the light load losses is a must, the use of a zener or transil clamp (see fig. 5b) is recommended whenever possible. Such circuit gives also a better defined clamping level but dissipates more power at full load.

Figure 5. Suggested clamp circuit topologies

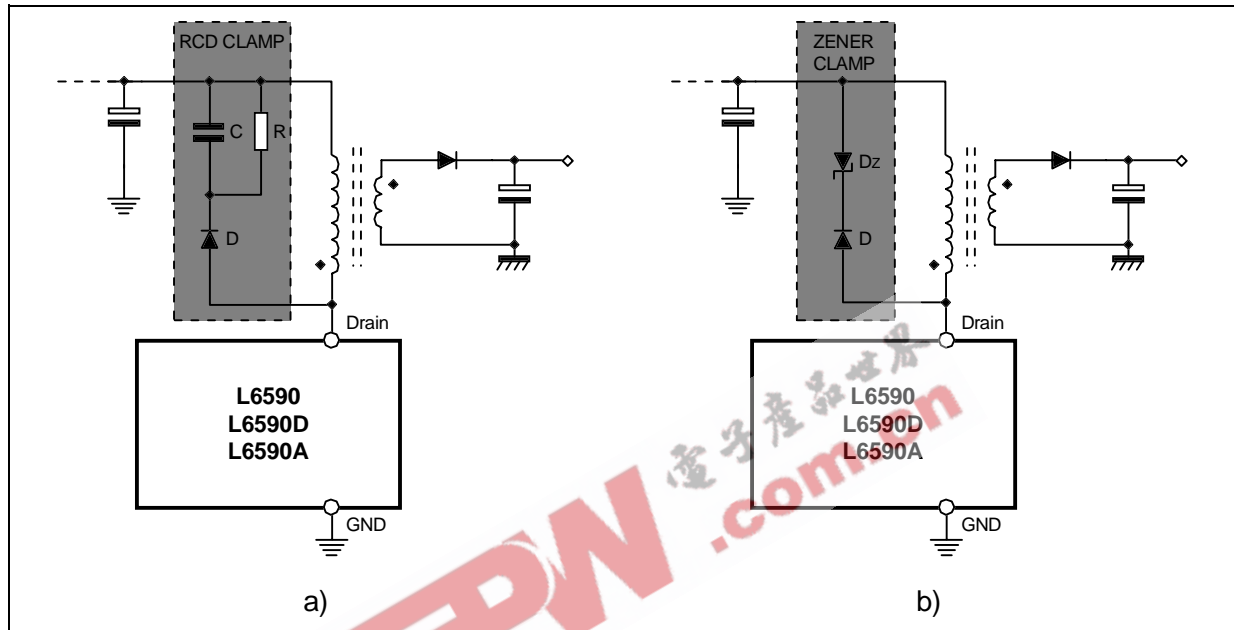

The clamp may not be necessary in a 110V_{AC} operated converter but, before giving up this circuit, it is important to check carefully the spike under overload and start-up conditions to make sure that the voltage rating of the MOSFET is never exceeded.

RCD clamp. The clamp capacitor is charged by the energy stored in the leakage inductance and must ensure that the maximum allowed overvoltage V_{spike} is never exceeded, even under short circuit conditions (when the peak primary current is $I_{lim} = 0.7$ A). Its minimum value will be then:

$$C_{min} = \frac{L_{LK} \cdot I_{lim}^2}{(V_R + V_{spike})^2 - V_R^2}$$

The capacitor must be low-loss type (with polypropylene or polystyrene film dielectric) to reduce power dissipation and prevent overheating due to the high peak currents it experiences.

The minimum value of the clamp resistance is:

$$R_{min} = \frac{1}{f_{sw} \cdot C_{min} \cdot \ln\left(1 + \frac{V_{spike}}{V_R}\right)}$$

and its power rating has to be:

$$P_R = \frac{V_R^2}{R_{min}} + \frac{1}{2} \cdot L_{LK} \cdot I_{lim}^2 \cdot f_{sw}$$

Usually the resistor value will be selected much higher than the minimum to reduce losses. The clamp capacitor will then be quite larger than the minimum as well.

The blocking diode must be not only very fast-recovery but also very fast-turn-on type to avoid additional drain overvoltage. A 1A rated diode with a breakdown voltage at least $V_{PKmax} + V_R$ is needed. Table 12 shows the suggested ST parts.

Table 12. Recommended ST parts for blocking diode.

110 V _{AC}			220 V _{AC} or WRM		
Diode	V _{RRM}	Package	Diode	V _{RRM}	Package
BYT01-400	400	F126	STTA106	600	F126
SMBYT01-400	400	SMB	STTA106U	600	SMB

Zener clamp. The Transil (or zener) clamp voltage should be equal to:

$$V_{CL} = V_R + V_{spike} \tag{16}$$

Usually Transils are rated by their stand-off Voltage V_{RM} at 25°C temperature, which is defined at low current, whereas the desired clamp voltage is to be considered at operating junction temperature and I_{lim} current.

To take this into consideration, as a rule of thumb the stand-off voltage can be selected as high as 70% of the desired clamp level. Please refer to [2] and [3] to see how these problems are handled.

The Transil or zener must have an adequate power handling capability in steady state operation:

$$P_z = \frac{1}{2} \cdot \frac{V_{CL}}{V_{CL} - V_R} \cdot L_{LK} \cdot I_{lim}^2 \cdot f_{sw}$$

Table 13 lists some recommended devices available from ST.

The same recommendations as in the RCD clamp case apply to the blocking diode in series to the Transil. Only the breakdown voltage could be derated to V_{PKmax} .

Table 13. Recommended ST parts for clamping.

V _R	P _z ≤ 0.75 W	P _z = 1W	P _z = 1.5W
≤100 V	BZW04-154 BZW06-154 SMAJ154A-TR	BZW04-154 BZW06-154 SMBJ154A-TR	P6KE180A 1.5KE180A SMCJ154A-TR
130 V	BZW04-188 BZW06-188 SMAJ188A-TR	BZW04-188 BZW06-188 SMBJ188A-TR	P6KE200A 1.5KE200A SMCJ188A-TR

11 SECONDARY RECTIFIER SELECTION

Although the converter is operated in DCM, it is recommended to use an ultrafast p-n diode or, whenever allowed by the reverse voltage, a Schottky type. The latter, besides optimizing the reverse recovery, minimizes conduction losses as well.

The voltage rating will be higher than the maximum reverse voltage it experiences:

$$V_{REV} = V_{out} \cdot \left(1 + \frac{V_{PKmax}}{V_R} \right), \tag{17}$$

with a suitable safety margin (usually 20-25%). As to its current rating, it is a common design practice to choose a diode rated for 2-3 times the DC output current I_{out} . Table 14 lists some recommended devices available from ST assuming $V_R = 130$ V. In each cell of the table there are two recommended devices, the first one is an axial or through-hole diode and the second one is in SMD package. The sale types in italic are p-n diodes, the others are Schottky type.

Table 14. Recommended ST parts for secondary rectification.

V _{out} (V)	110 VAC			220 VAC or WRM		
	P _{out} ≤5W	P _{out} =7.5W	P _{out} =10W	P _{out} ≤5W	P _{out} =7.5W	P _{out} =10W
3.3	1N5820 STPS5L25B	STPS5L25B-1 STPS5L25B	STPS10L25D STPS10L25G	1N58210 STPS3L25S	STPS5L25B-1 STPS5L25B	STPS10L25D STPS10L25G
5	1N5820 STPS5L25B	1N5820 STPS5L25B	STPS10L25D STPS10L25G	1N5821 STPS340C	1N5822 STPS340B	STPS640CT STPS640CB
9	1N5821 STPS2L30A	1N5821 STPS340B	1N5822 STPS340B	– STPS160U	– STPS3L60S	STPS5H100-1 STPS3L60S
12	1N5819 STPS1L40A	1N5822 STPS3L60S	– STPS3L60S	– STPS1H100U	– STPS2H100U	STPS5H100B-1 STPS2H100U
15	BYV10-60 STPS160A	BYV10-60 STPS160A	– STPS3L60S	– STPS1H100U	– STPS2H100U	STPS5H100B-1 STPS2H100U
18	BYV10-60 STPS160A	BYV10-60 STPS1H100U	BYW98-100 STPS2H100U	– STPS1H100U	– STPS2H100U	STPS5H100B-1 STPS2H100U
24	BAT49 STPS1H100A	– STPS1H100U	– STPS1H100U	BYW100-200 STPR120A	BYW100-200 STPR120A	BYW100-200 SMBYW02-200

12 OUTPUT CAPACITOR SELECTION AND POST FILTER

Large, low-ESR electrolytic capacitors usually do the filtering work. The parameters to be considered for their selection are the working voltage, RMS ripple rating and ESR, the actual capacitance value is of secondary importance.

Obviously, the DC working voltage must be greater than V_{out} . A margin of 25% is recommended for the sake of reliability.

The AC current the output capacitor undergoes causes power dissipation on its ESR and a resulting temperature rise. This is the major responsible for capacitor degrading. Thus it is important not to operate the capacitor beyond its AC current ripple rating, otherwise its lifetime will be considerably shortened. This parameter is usually specified at 85°C or 105°C ambient temperature, depending on capacitor's quality. The value could be derated considering the actual maximum ambient temperature (T_{amb}) and the capacitor's target lifetime. For a conservative design no derating will be applied. The AC current capability must then be larger than I_{sAC} and

may be achieved by using paralleled capacitors.

ESR, besides being responsible for capacitor heating, is what basically determines the switching frequency voltage ripple superimposed on top of the DC value. This is true as long as the capacitive contribution to the ripple is negligible, that is if:

$$C_{out} \gg 100 \cdot \frac{I_{out} \cdot D_x}{V_{r\%} \cdot V_{out} \cdot f_{sw}} \quad (18)$$

The specification on the maximum allowed output ripple is then translated into a requirement on the maximum ESR of the capacitor:

$$ESR_x = \frac{V_{r\%}}{100} \cdot \frac{V_{out}}{I_{S_{pk}}} \quad (19)$$

Anyway, once the specification on either the AC ripple current or the ESR is fulfilled, the resulting capacitance value definitely meets condition (18).

If the requirement on ESR is very tight, there is an alternative to using a large number of output capacitors: it is possible to tolerate a higher ripple on C_{out} (provided the AC ripple requirement is met) and add an LC post filter, like the one shown in fig. 6, that attenuates the ripple to the desired level.

Figure 6. Output post filter for ripple reduction

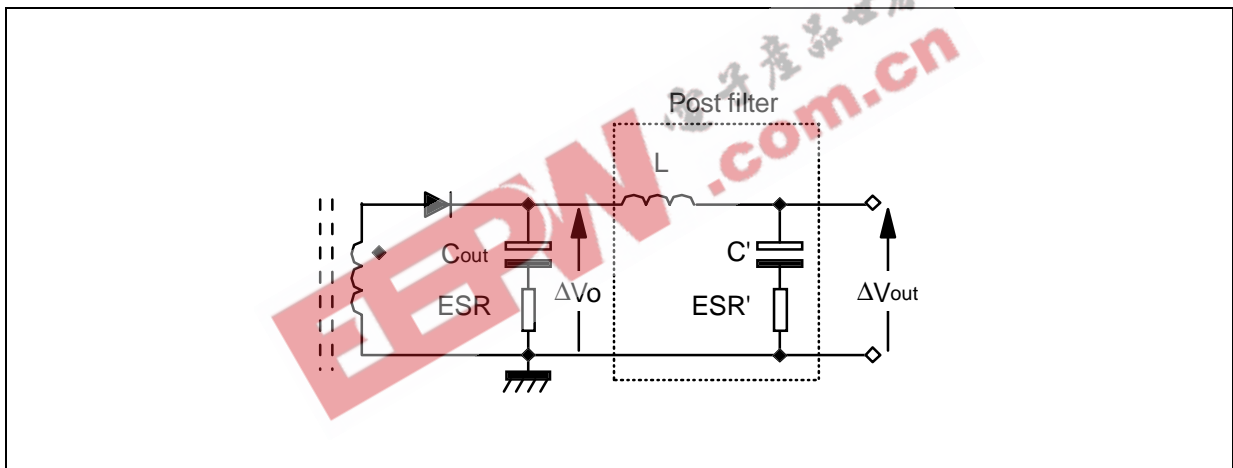

The attenuation factor of such filter is approximately given by:

$$K_a = \frac{\Delta V_{out\ p-p}}{\Delta V_{O\ p-p}} \approx D \cdot (1 - D) \cdot \frac{ESR'}{f_{sw} \cdot L}$$

which is the same for complementary duty cycles and minimum for $D=0.5$. Thus, to get the desired attenuation factor the following design equations can be applied:

$$K_a = \frac{ESR'}{4 \cdot f_{sw} \cdot L} \quad \text{for } D_x > 0.5 \quad K_a = D_x \cdot (1 - D_x) \cdot \frac{ESR'}{f_{sw} \cdot L} \quad \text{for } D_x < 0.5$$

It is convenient to choose an off-the-shelf choke and then select a capacitor with an ESR low enough to get the desired attenuation level. For low output current (less than 1 A) ferrite beads may be used. At any rate, the DC current rating of the choke should be oversized to minimize DC voltage drop. In fact, the feedback should be connected upstream the post filter to avoid stability problems (see "Control loop compensation" section).

13 SELF-SUPPLY CIRCUIT DESIGN

To define the self-supply circuit it is necessary to select the bias rectifier and the supply capacitor (see fig. 7) since the turns number of the auxiliary winding has been defined already.

The bias rectifier has to withstand a reverse voltage equal to:

$$V_{REV} = V_{CC} \cdot \left(1 + \frac{V_{PKmax}}{V_R}\right)$$

with an appropriate safety margin of 20-25%. The current rating is of little concern since the diode has to carry few mA. A popular 1N4148 (75V rating) or an UF4003 (200V rating) may be suitable choices.

The supply capacitor has to be large enough to keep the device running during the time needed for the auxiliary winding to develop its correct voltage at start-up. A minimum value of 10 μF is recommended and any low cost electrolytic capacitor will do the job. The resistor Rs in series to D filters the voltage spike appearing on the positive-going edge of the voltage generated by the self-supply winding that causes the voltage Vcc to increase with the converter's output load. The optimum value depends on the transformer's stray parameters (mainly the coupling between the auxiliary and the secondary winding) and can be found empirically once the transformer spec and construction have been frozen. A small and inexpensive axial inductor in the range of 1 to 10μH may be used instead of Rs, with even better results.

Figure 7. Self-supply circuit

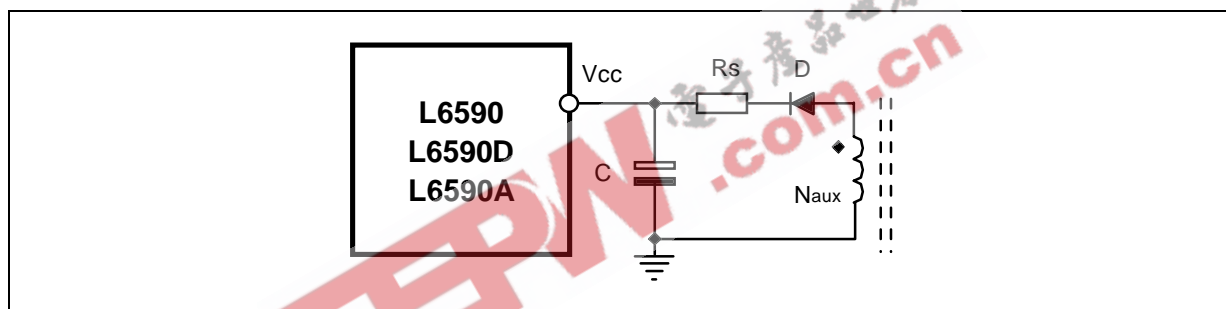

14 BROWNOUT PROTECTION DESIGN (L6590A AND L6590D ONLY)

With reference to the schematic of fig. 8, the following relationships can be established for the ON (VinON) and OFF (VinOFF) thresholds of the input voltage:

$$V_{inON} \cdot \frac{R2}{R1 + R2} = 2.5,$$

$$\frac{V_{inOFF} - 2.5}{R1} + 50 \cdot 10^{-6} = \frac{2.5}{R2}.$$

Solving for R1 and R2:

$$R1 = \frac{V_{inON} - V_{inOFF}}{50 \cdot 10^{-6}}$$

$$R2 = R1 \cdot \frac{2.5}{V_{inON} - 2.5}$$

For a proper operation of this function, VinON must be less than VPKmin and VinOFF less than Vinmin (see the timing diagram of figure 8).

Figure 8. Brownout protection circuit and timing diagram

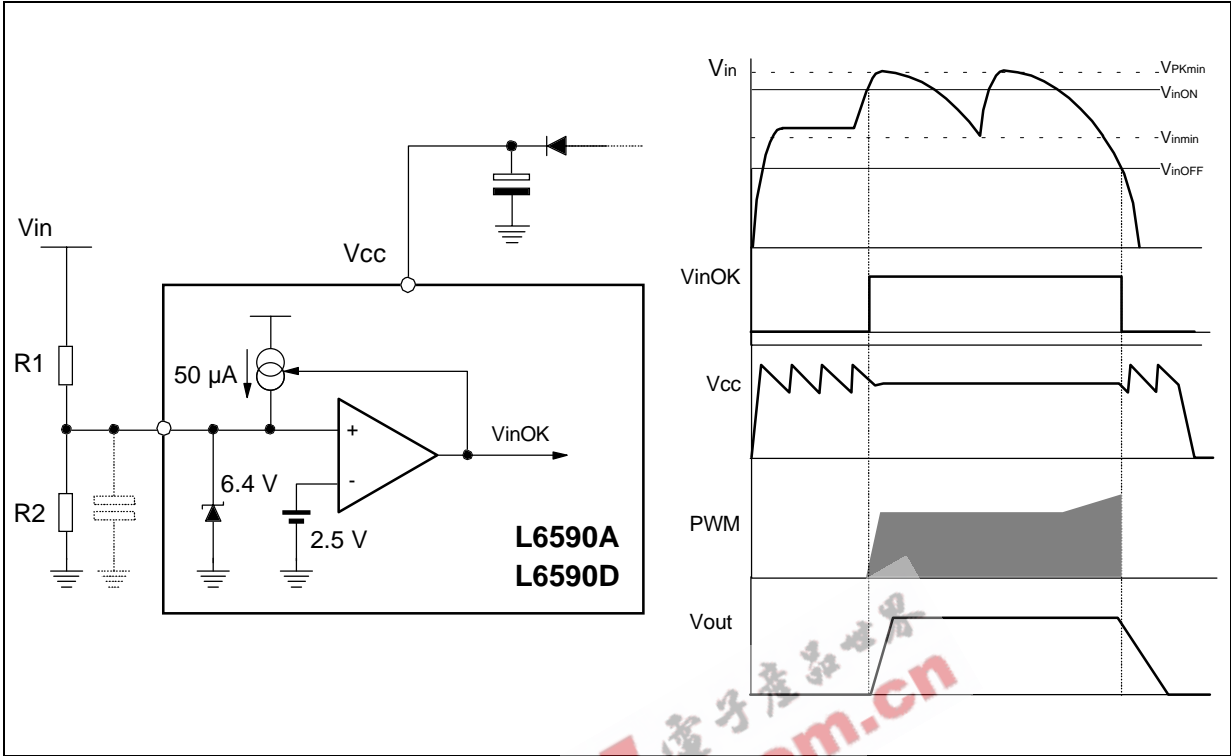

15 CONTROL LOOP DESIGN

The control loop can be summarized as shown in figure 9, where each block is described by its transfer function in the complex frequency domain represented by means of a Bode plot.

Figure 9. Control loop Block Diagram

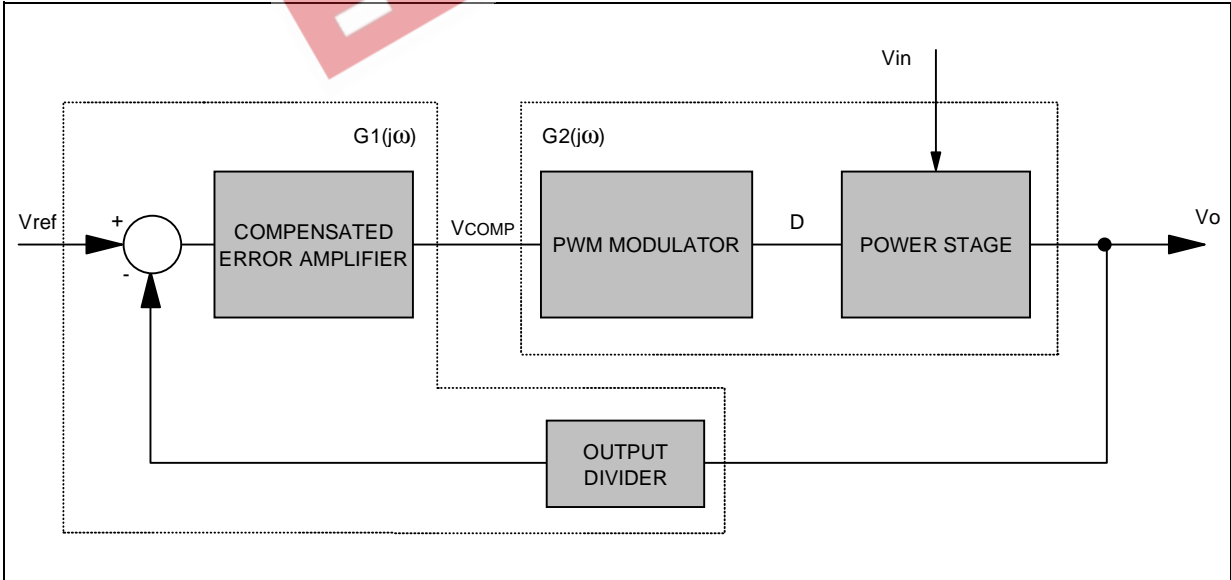

The set PWM modulator + Power stage is what, in control theory terminology, is called the "plant", while the compensated error amplifier is the "controller".

The transfer function $G2(j\omega)$ of the plant is defined by the control method (voltage mode), the topology of the converter (flyback) and its operating mode (DCM in the specific case). The task of the control loop design is then to determine the transfer function $G1(j\omega)$ of the error amplifier and define the relevant frequency compensation network. The objective of the design is to ensure that the resulting closed-loop system will be stable and well performing in terms of dynamic response, line and load regulation.

The characteristics of the closed-loop system can be inferred from its open-loop properties. Provided the open-loop gain crosses the 0 dB axis only once at $f = f_c$ (crossover frequency), stability will be ensured if the gain phase shift (besides the 180° due to negative feedback) is less than 180° at $f = f_c$. This is the well-known Nyquist's stability criterion.

Anyway, adequate margin to this boundary condition must be provided to prevent instability due to parameter variations and to optimize the dynamic response that would be severely underdamped otherwise. Under worst case condition this "phase margin" Φ_m should never go below 20° or 30° . Typically, $\Phi_m = 45^\circ$ in nominal conditions is used as a design guideline: this ensures fast transient response with very little ringing. Sometimes a higher margin (up to 60° or 75°) is required to account for very large spreads in line, load and temperature changes as well as manufacturing tolerances.

Although Nyquist's criterion allows the phase shift to be over 180° at a frequency below f_c , this is not recommended because it would result in a conditionally stable system. A reduction of the gain (which may temporarily happen during large load transients) would cause the system to oscillate, therefore the phase shift should not get close to 180° at any frequency below f_c .

Optimum dynamic performance requires a large gain bandwidth, that is the crossover frequency f_c to be pushed as high as possible ($\leq f_{sw}/4$). When optimum dynamic performance is not a concern, f_c will be typically chosen equal to $f_{sw}/10$.

Good load and line regulation implies a high DC gain, thus the open loop gain should have a pole at the origin. In this way the theoretical DC gain would tend to infinity, whereas the real-world one will be limited by the low-frequency gain of the Error Amplifier. Since voltage mode control has poor open-loop line regulation, the overall gain should be still high also at frequencies around 100-120 Hz to maximize rejection of the input voltage ripple. This is related to phase margin: a higher phase margin leads to a lower low-frequency gain.

Once the goal of the design has been established in terms of crossover frequency and phase margin, the next step is to determine the transfer function of the plant $G2(j\omega)$ in order to select an appropriate structure for $G1(j\omega)$.

The transfer function $G2(j\omega)$ of the plant is described in Tab. 15, while its asymptotic Bode plot is illustrated in Fig.10.

In $G2_0$ definition the ratio D_{max}/V_s is the PWM modulator gain, while $D_{max} = 0.7$ is the maximum duty cycle and $V_s = (3.5-1.5) = 2$ V is the oscillator peak-to-valley swing (see the relevant section). $R_{out} = V_{out}/I_{out}$ is the equivalent load resistor.

This kind of plant will be stabilized in closed-loop operation by what is commonly known as a Type 2 amplifier. Its transfer function $G1(j\omega)$, which comprises a pole at the origin and a zero-pole pair, is defined as:

$$G1(j\omega) = \frac{G1_0}{j\omega} \cdot \frac{1 + \frac{j\omega}{\omega_z}}{1 + \frac{j\omega}{\omega_p}}$$

Its asymptotic Bode plot is illustrated in Fig. 11.

The main task of this correction is to boost the phase of the overall loop (actually, to reduce the phase lag of $G2(j\omega)$) in the neighborhood of the crossover frequency.

Figure 10. Plant transfer function G2(jω) of DCM Flyback (Bode Plots)

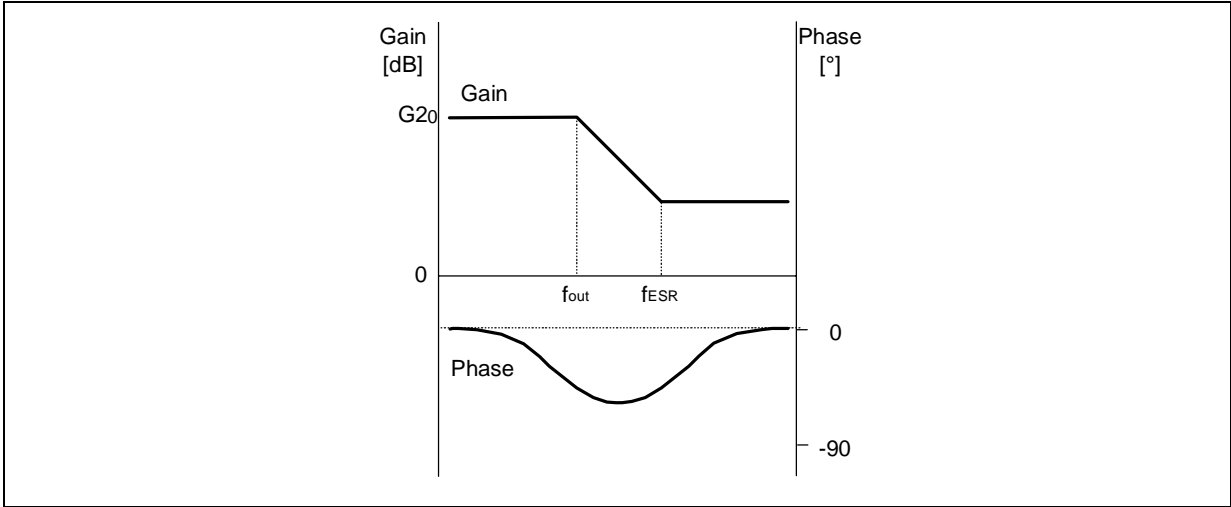
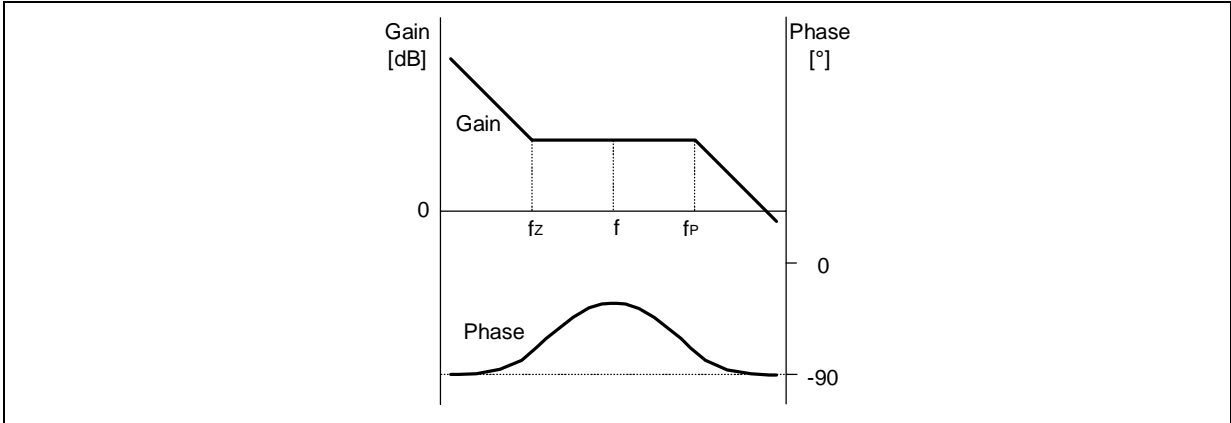

Table 15. Plant Transfer Function and its Main Quantities

Symbol	Definition
$G2(j\omega)$	$G2(j\omega) = G2_0 \cdot \frac{1 + \frac{j\omega}{\omega_{ESR}}}{1 + \frac{j\omega}{\omega_{out}}}$
$G2_0$	$G2_0 = \frac{D_{max}}{V_s} \cdot V_{in} \cdot \frac{R_{out}}{\sqrt{2 \cdot L_p \cdot f_{sw}}}$
f_{ESR}	$f_{ESR} = \frac{\omega_{ESR}}{2 \cdot \pi} = \frac{1}{2 \cdot \pi \cdot ESR \cdot C_{out}}$
f_{out}	$f_{out} = \frac{\omega_{out}}{2 \cdot \pi} = \frac{1}{\pi \cdot R_{out} \cdot C_{out}}$

Figure 11. Controller Transfer Function G1(jω) (Bode Plots)



AN1262 APPLICATION NOTE

The synthesis of $G1(j\omega)$ can be done by following the following step-by-step procedure:

a) Calculate gain and phase of $G2(j\omega)$ at the desired crossover frequency (f_c). That is:

$$G2_c = |G2(2 \cdot \pi \cdot f_c)|$$

$$\Phi2_c = \frac{180}{\pi} \cdot \arg[G2(2 \cdot \pi \cdot f_c)];$$

$G2(j\omega)$ will be calculated at maximum input voltage and maximum load, where the gain-bandwidth product is maximum.

b) Calculate gain and phase of $G1(j\omega)$ at $f = f_c$ in order for the overall open-loop gain to cross the 0 dB axis at $f = f_c$ with the phase margin Φ_m :

$$G1_c = |G1(2 \cdot \pi \cdot f_c)| = \frac{1}{G2_c};$$

$$\Phi1_c = \frac{180}{\pi} \cdot \arg[G1(2 \cdot \pi \cdot f_c)] = -180 + \Phi_m - \Phi2_c,$$

c) Cancel the pole of $G2(j\omega)$ by placing the zero of $G1(j\omega)$ in the neighborhood:

$$f_z = \frac{\omega_z}{2 \cdot \pi} = \alpha \cdot \frac{\omega_{out}}{2 \cdot \pi} \quad (\alpha = 1 \text{ to } 5)$$

d) Place the pole of $G1(j\omega)$ so as to get the desired phase margin:

$$f_p = \frac{\omega_p}{2 \cdot \pi} \approx \frac{f_c}{\left| \tan\left(\frac{\pi}{180} \cdot \Phi1_c\right) \right|}$$

e) Calculate the unity gain frequency $G1_0$:

$$G1_0 \approx 2 \cdot \pi \cdot G1_c \cdot \frac{f_c \cdot f_z}{f_p}$$

The synthesis of $G1(j\omega)$ is completed. The following step will concern the practical implementation of such function, that is the realization of a Type 2 amplifier. This will be done considering two cases, the secondary and the primary sensing feedback.

16 SECONDARY FEEDBACK IMPLEMENTATION

This kind of feedback, shown in fig. 12, uses a popular arrangement with a TL431 as secondary reference/error amplifier and an optocoupler to transfer the control signal to the primary side. The error amplifier of the IC is then used as a current source whose characteristic is shown in fig. 12 as well: the voltage V_{COMP} is changed (and the duty cycle is controlled) by modulating the current I_C sunk from the pin. A change of I_C causes a change of V_{COMP} corresponding to a resistance $R_{COMP} = 9 \text{ k}\Omega$. The resulting transfer function is:

$$G1(j\omega) = \frac{\Delta V_{COMP}}{\Delta V_{out}} = \frac{\Delta V_{COMP}}{\Delta I_C} \cdot \frac{\Delta I_C}{\Delta I_F} \cdot \frac{\Delta I_F}{\Delta V_K} \cdot \frac{\Delta V_K}{\Delta V_{out}} = \frac{CTR_{max} \cdot R_{COMP}}{R_B \cdot R_H \cdot C_F} \cdot \frac{1}{j\omega} \cdot \frac{1 + j\omega \cdot (R_H + R_F) \cdot C_F}{1 + j\omega \cdot R_{COMP} \cdot C_{COMP}}$$

and table 16 shows how its quantities are defined

Figure 12. Secondary feedback: TL431 + optocoupler circuit (I)

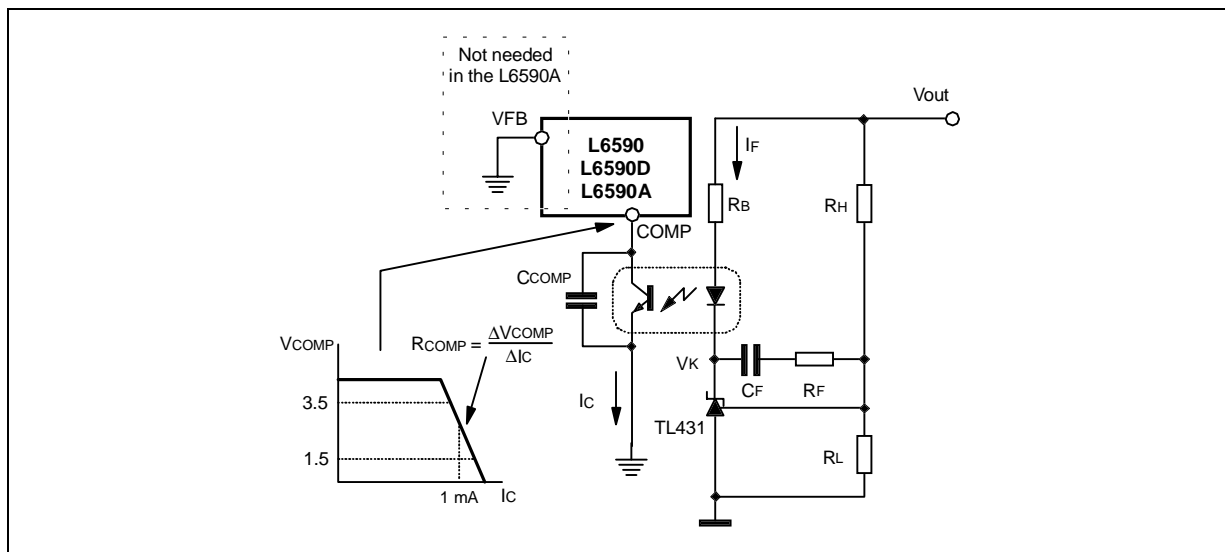

Table 16. G1(jω) Implementation: secondary feedback (I)

Symbol	Definition
R_L	$R_L \approx 0.27 \text{ to } 2.7 \text{ [k}\Omega\text{]}$
R_H	$R_H = \frac{V_{out} - 2.5}{2.5} \cdot R_L$
R_B	$R_B < CTR_{min} \cdot \frac{V_{out} - 3.5}{I_{Cmax}}$
C_F	$C_F = \frac{CTR_{max} \cdot R_{COMP}}{R_B \cdot R_H \cdot G1_0}$
R_F	$R_F = \frac{1}{2 \cdot \pi \cdot f_Z \cdot C_F} - R_H$
C_{COMP}	$C_{COMP} = \frac{1}{2 \cdot \pi \cdot f_P \cdot R_{COMP}}$

This technique provides very good regulation of the output voltage and galvanic isolation from the primary side at the same time.

In Table 16 it is possible to find the design relationships useful to derive the part values. I_{Cmax} is specified in the Datasheet (2.5mA).

The following condition should be met:

$$\frac{CTR_{max}}{CTR_{min}} \leq G1_c \cdot \frac{\left| \tan\left(\frac{\pi}{180} \cdot \Phi1_c\right) \right|}{R_{COMP}} \cdot \frac{V_{out} - 3.5}{I_{Cmax}}, \quad (20)$$

otherwise it will not be possible to find a positive value for R_F . If the condition (20) is not met, an optocoupler with a narrower $CTR_{min} - CTR_{max}$ spread should be selected. If that is not possible, either a higher f_c or a lower Φ_m should be selected and the calculations from step a) to step e) redone.

Figure 13. PWM gain reduction by R_C (secondary feedback II).

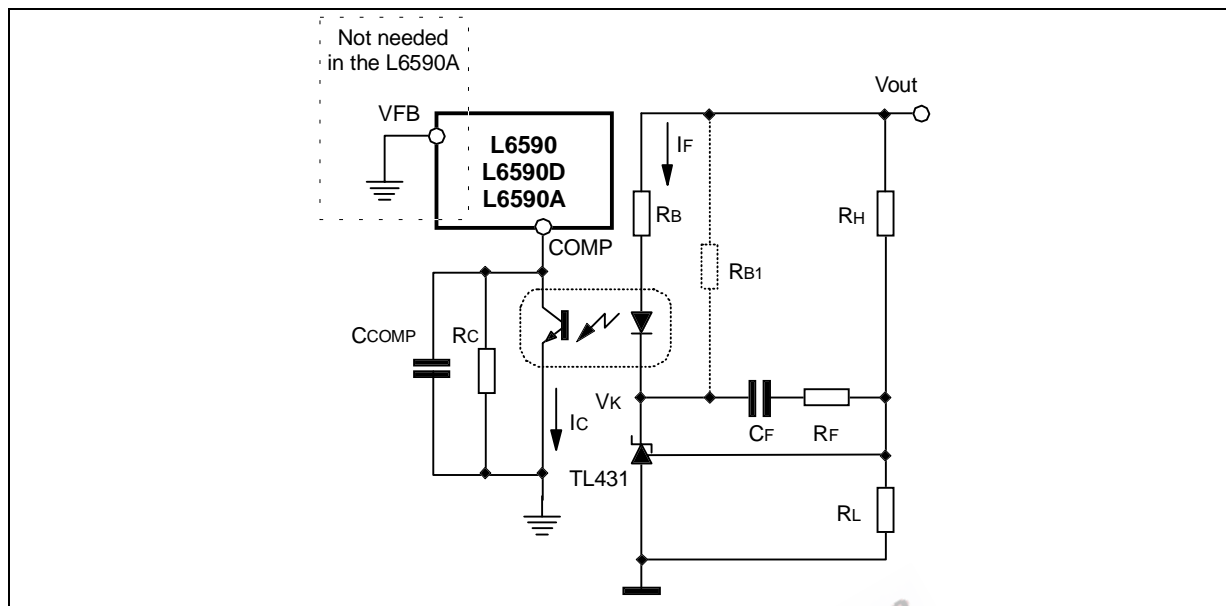

A resistor R_C in parallel to C_{COMP} , as shown in fig. 13, is useful to reduce the PWM gain $\Delta V_{COMP}/\Delta I_C$. In fact, the resistor comes dynamically in parallel to R_{COMP} , thus reducing the equivalent value appearing at the numerator of the gain. Moreover, since it diverts part of the current sourced by the pin COMP, the opto's transistor carries less current and a slightly higher bias resistor R_B can be used, thus giving some extra gain reduction. An additional resistor, R_{B1} , of some $k\Omega$ could be needed to guarantee sufficient bias to the TL431.

To be able to exploit the full dynamics of the error amplifier under worst case conditions, R_C must not be lower than $7\text{ k}\Omega$, which reduces the gain by a $1/0.35 \approx 2.86$ factor. R_C values lower than $7\text{ k}\Omega$ will reduce the gain further on but will reduce also the maximum duty cycle allowed (worst case). Depending on the maximum duty cycle specified for a given application, this can be acceptable.

Table 17 summarizes the situation for different values of R_C .

Table 17. PWM gain reduction for different R_C values

R_C (k Ω)	$R_C // R_{COMP}$ (k Ω)	D_{max}	PWM Gain Reduction	K_B (R_B multiplier)	Total Gain Reduction
7.5	4.09	0.7	2.2	1.24	2.73
7	3.94	0.7	2.29	1.25	2.86
6.8	3.87	0.68	2.32	1.25	2.91
6.2	3.67	0.62	2.45	1.27	3.11
5.6	3.45	0.55	2.61	1.28	3.34
5.1	3.26	0.49	2.76	1.29	3.58
4.7	3.09	0.44	2.91	1.31	3.8
4.3	2.91	0.38	3.09	1.32	4.07
3.9	2.72	0.32	3.31	1.33	4.4
3.6	2.57	0.28	3.5	1.34	4.69

In this case the design procedure outlined in table 16 should be slightly modified as shown in table 18.

Table 19. G1(jω) Implementation: secondary feedback (III)

Symbol	Definition
R _{F2} ; R _C	R _{F2} > 2kΩ ; R _C < 2.5 · R _{F2}
R _E	R _E > 1kΩ
R _L	R _L ≈ 0.27 to 2.7 [kΩ]
R _H	$R_H = \frac{V_{out} - 2.5}{2.5} \cdot R_L$
R _B	$R_B < CTR_{min} \cdot \frac{V_{out} - 3.5}{2.5} \cdot R_E$
C _{F1}	$C_{F1} = \frac{CTR_{max} \cdot R_E \cdot R_{F2}}{(R_E + R_C) \cdot R_B \cdot R_H \cdot G1_0}$
R _{F1}	$R_{F1} = \frac{1}{2 \cdot \pi \cdot f_Z \cdot C_{F1}} - R_H$
C _{F2}	$C_{F2} = \frac{1}{2 \cdot \pi \cdot f_P \cdot R_{F2}}$

Figure 15 shows a special configuration, with the optocoupler connected in series to the supply pin of the IC that provides the following benefits:

- a) a large range of the voltage generated by the auxiliary winding can be allowed since the changes are "damped" by the phototransistor and V_{CC} is stabilized by the error amplifier; this is useful with a poor quality transformer or when the output voltage (tracked by the auxiliary voltage) may decrease because of constant current regulation (e.g. battery chargers, see fig.40 on L6590's datasheet).
- b) during overload and short circuit the power throughput is automatically reduced because the operation of the device becomes intermittent. In fact, the phototransistor carries the quiescent current I_Q of the IC and, if the output voltage is too low, there will not be enough current through the photodiode at the secondary side to maintain I_Q. The device will be switched off as it goes into UVLO.
- c) despite the IC's OVP protection is bypassed by such configuration, the system is still protected against optocoupler's failures: if that happens, the phototransistor will no longer be able to supply the IC, which will go into UVLO just like in case of overload or short circuit.

The transfer function of the schematic of Fig. 15 is:

$$G1(j\omega) = \frac{\Delta V_{COMP}}{\Delta V_{out}} = \frac{\Delta V_{COMP}}{\Delta V_{CC}} \cdot \frac{\Delta V_{CC}}{\Delta I_C} \cdot \frac{\Delta I_C}{\Delta I_F} \cdot \frac{\Delta I_F}{\Delta V_K} \cdot \frac{\Delta V_K}{\Delta V_{out}} =$$

$$= CTR_{max} \cdot \frac{R_{F2}}{R_B} \cdot \frac{1}{j\omega \cdot R_{H1} \cdot C_{F1}} \cdot \frac{(1 + j\omega \cdot R_C \cdot C_s) \cdot [1 + j\omega \cdot (R_{H1} + R_{F1}) \cdot C_{F1}]}{[1 + j\omega \cdot (R_{H2} + R_C) \cdot C_s] \cdot (1 + j\omega \cdot R_{F2} \cdot C_{F2})}$$

The V_{CC} capacitor has a significant effect on the frequency characteristic of this circuit: in particular, it introduces a low-frequency pole that causes a phase lag noxious for the phase margin. This pole needs to be compensated by a zero, which requires an additional resistor (R_C) in series to the capacitor.

The zero (R_{H1}+ R_{F1}) · C_{F1} will be placed close to the pole due to the V_{CC} capacitor, (R_{H2}+R_C)·C_s so as to compensate it. The pole at the origin and the other zero-pole pair realize a type 2 amplifier (see Table 20 to see how

Figure 15. Secondary feedback: TL431 + optocoupler circuit (IV)

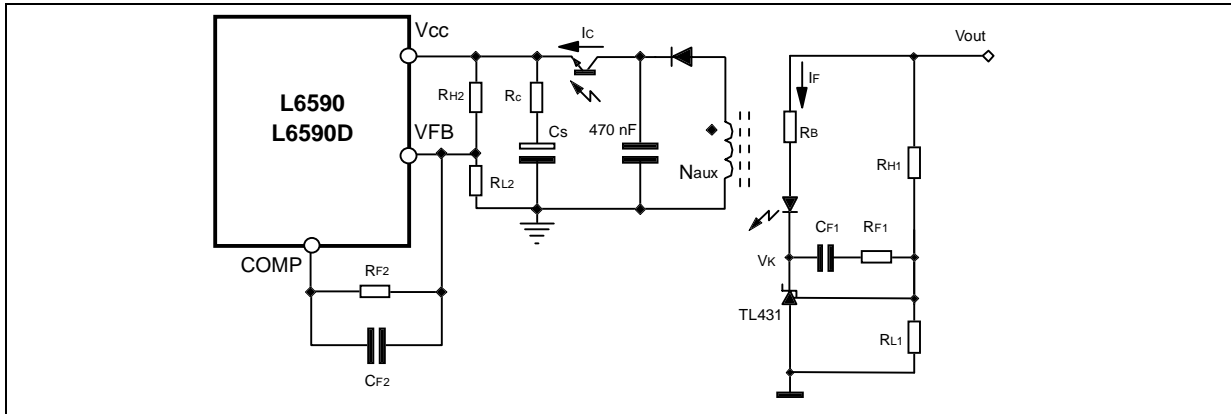

Table 20. G1(jω) Implementation: secondary feedback (IV)

Symbol	Definition
$R_{L2}; R_{H2}$	$R_{L2} > \frac{15V}{V_{CC}}$ [kΩ] ; $R_{H2} = \frac{V_{CC} - 2.5}{2.5} \cdot R_{L2}$
R_{F2}	$R_{F2} > 0.4 \cdot R_{H2}$
R_{L1}	$R_{L1} \approx 0.27$ to 2.7 [kΩ]; $R_{H1} = \frac{V_{out} - 2.5}{2.5} \cdot R_{L1}$
R_B	$R_B < CTR_{min} \cdot \frac{V_{out} - 3.5}{I_Q + \frac{2.5}{R_{L2}}}$
R_C	$R_C = \frac{1}{2 \cdot \pi \cdot f_z \cdot C_S}$
C_{F1}	$C_{F1} = \frac{CTR_{max} \cdot R_{F2}}{R_B \cdot R_{H1} \cdot G_{10}}$
R_{F1}	$R_{F1} = \frac{(R_{H2} + R_C) \cdot C_S}{C_{F1}} - R_{H1}$
C_{F2}	$C_{F2} = \frac{1}{2 \cdot \pi \cdot R_{F2} \cdot f_P}$

this network can be designed). The bias resistor of the photodiode will be selected so as to sustain the quiescent current of the L6590 and the current through the divider $R_{H2}+R_{L2}$. Please note that the steady state supply voltage V_{CC} (used in table 20 to choose R_{L2} and R_{H2}) has to be sufficiently higher than the UVLO threshold (say 3-4 V, depending on C_S). In fact, the PWM starts only when the V_{CC} voltage has decayed from the start-up threshold to the neighborhood of the steady state value. During this time the PWM is inhibited by the error amplifier, saturated low because the voltage at the pin V_{FB} is higher than 2.5V.

The turn number of the auxiliary winding will be such that the V_{CE} across the phototransistor never falls below 1-2 V, to let it work in its active region. In case of constant current regulation, the variation of the output voltage

AN1262 APPLICATION NOTE

must be accounted for as well (the minimum specified value will be considered) and the turn number may result quite high.

17 PRIMARY FEEDBACK IMPLEMENTATION

In this approach, which will be considered with regards to the L6590 and the L6590D only, the voltage generated by the self-supply winding is sensed and regulated. This solution, shown in fig. 16, is cheap because no optocoupler is needed, but provides poor regulation, especially as a result of load changes.

Ideally, the voltage generated by the self supply winding and the output voltage should be related by the N_{aux}/N_s turn ratio only. Actually, numerous non-idealities, mainly transformer's parasitics, cause the actual ratio to deviate from the ideal one. Line regulation is quite good, in the range of $\pm 2\%$, whereas load regulation is about $\pm 5\%$. Output voltage tolerance is instead in the range of $\pm 10\%$. The resulting transfer function is:

$$G1(j\omega) = \frac{\Delta V_{COMP}}{\Delta V_{out}} = \frac{N_{aux}}{N_s} \cdot \frac{\Delta V_{COMP}}{\Delta V_{CC}} = \frac{N_{aux}}{N_s} \cdot \frac{1}{R_H \cdot (C_{Fs} + C_{Fp})} \cdot \frac{1}{j\omega} \cdot \frac{1 + j\omega \cdot R_F \cdot C_{Fs}}{1 + j\omega \cdot R_F \cdot \frac{C_{Fs} \cdot C_{Fp}}{C_{Fs} + C_{Fp}}}$$

Table 21 shows how its quantities are defined. As to the selection of V_{cc} , the same considerations concerning the circuit of fig. 15 apply to the circuit in fig. 16a. Such limitation is not in the circuit of fig. 16b.

Figure 16. Primary feedback: circuits

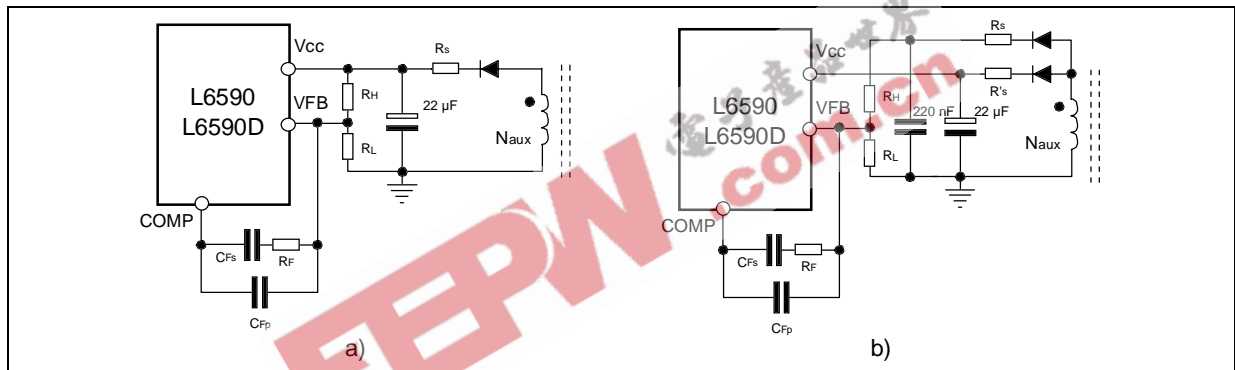

Table 21. $G1(j\omega)$ Implementation: Primary Feedback

Symbol	Definition
R_L	$R_L > \frac{15V}{V_{CC}} \quad [k\Omega]$
R_H	$R_H = \frac{V_{CC} - 2.5}{2.5} \cdot R_L$
C_{Fp}	$C_{Fp} = \frac{N_{aux}}{N_s} \cdot \frac{f_z}{f_p} \cdot \frac{1}{G1_0 \cdot R_H}$
C_{Fs}	$C_{Fs} = C_{Fp} \cdot \left(\frac{f_p}{f_z} - 1 \right)$
R_F	$R_F = \frac{1}{2 \cdot \pi \cdot f_z \cdot C_{Fs}}$

The value of the resistor R_s ($R's$ for the circuit of fig. 16b) in series to the bias diode will be selected to achieve minimum load regulation and its value may range from few units to some hundred ohm.

The optimum value will be found empirically once the transformer construction has been frozen. Also the divider R_H , R_L that sets the V_{CC} voltage (and as a consequence, the output voltage) is likely to need adjustment after bench verification. Some improvement in terms of load regulation can be achieved by using an inductor (typically, between 1 and $10\mu\text{H}$) instead of a resistor. Any inexpensive axial inductor able to carry few mA will serve the purpose.

Figure 17. Leading Edge Blanking (LEB) circuit for leakage inductance spikes filtering

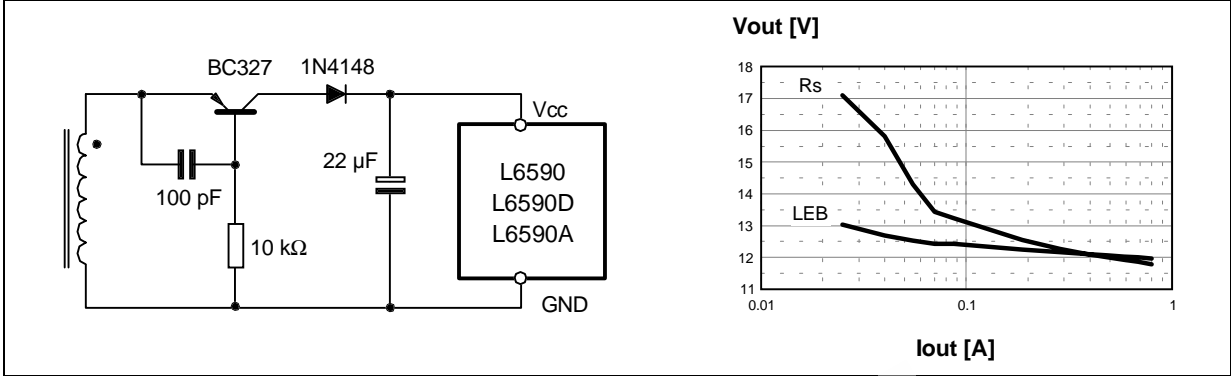

However, the most effective way to improve regulation is to use the circuit shown in figure 17, which blanks the spike appearing at the leading edges of the voltage generated by the self-supply winding. This spike, due to the transformer's leakage inductance, is the major responsible for the poor load regulation.

18 LAYOUT RECOMMENDATIONS

A proper printed circuit board (PCB) layout is essential for correct operation of any switch-mode converter and this is true for the devices of the L6590 family as well. Careful component placing, correct traces routing, appropriate traces widths and compliance with isolation distances are the major issues.

Figure 18. Suggested ground routing for converters with secondary feedback.

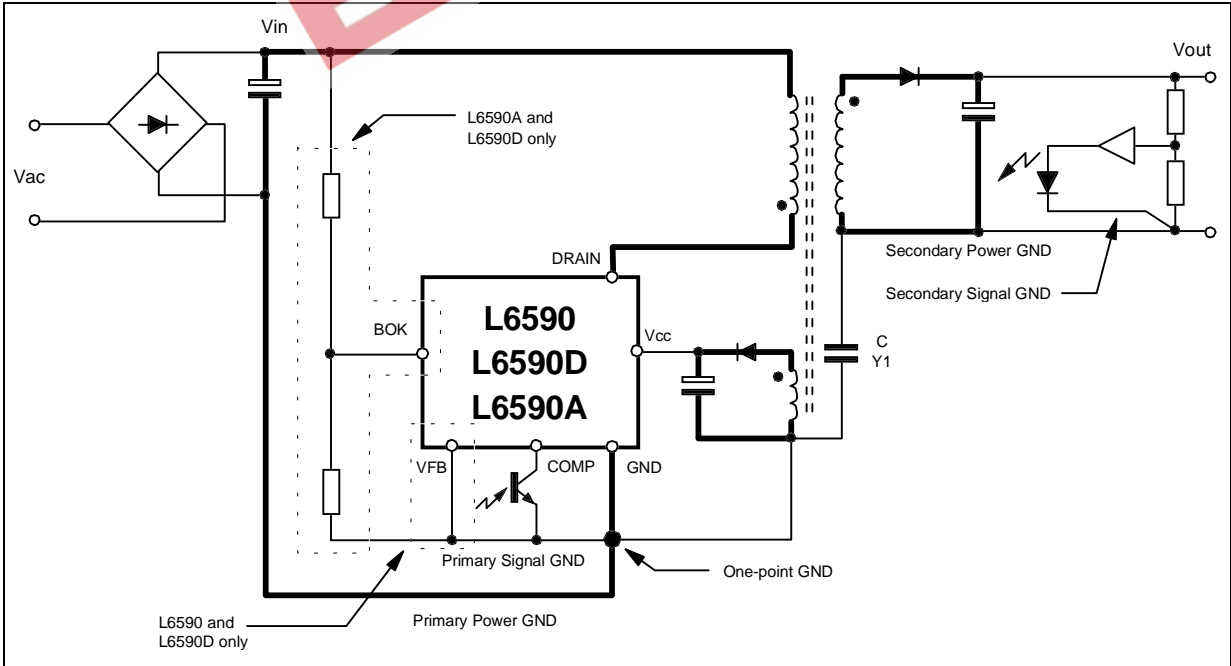

AN1262 APPLICATION NOTE

Some fundamental rules will be given to enable the designer to successfully produce a good layout.

All of traces carrying high currents, especially if pulsed (the bold ones in figures 18 and 19), should be as short and fat as possible. This will keep both resistive and inductive effects to a minimum, in favor of efficiency as well as radiated RFI. If a two layer PCB is used, some of these traces could be routed parallel on both sides.

Noise coupling and radiation will also be reduced by minimizing the area circumscribed by current loops where high pulsed currents flow, that is the bolded ones in figures 18 and 19. The most critical loop is that including the input bulk capacitor, the transformer and the L6590, thus these components should be next to one other. In figure 20 an example of possible component placement is given.

Figure 19. Suggested ground routing for converters with primary feedback

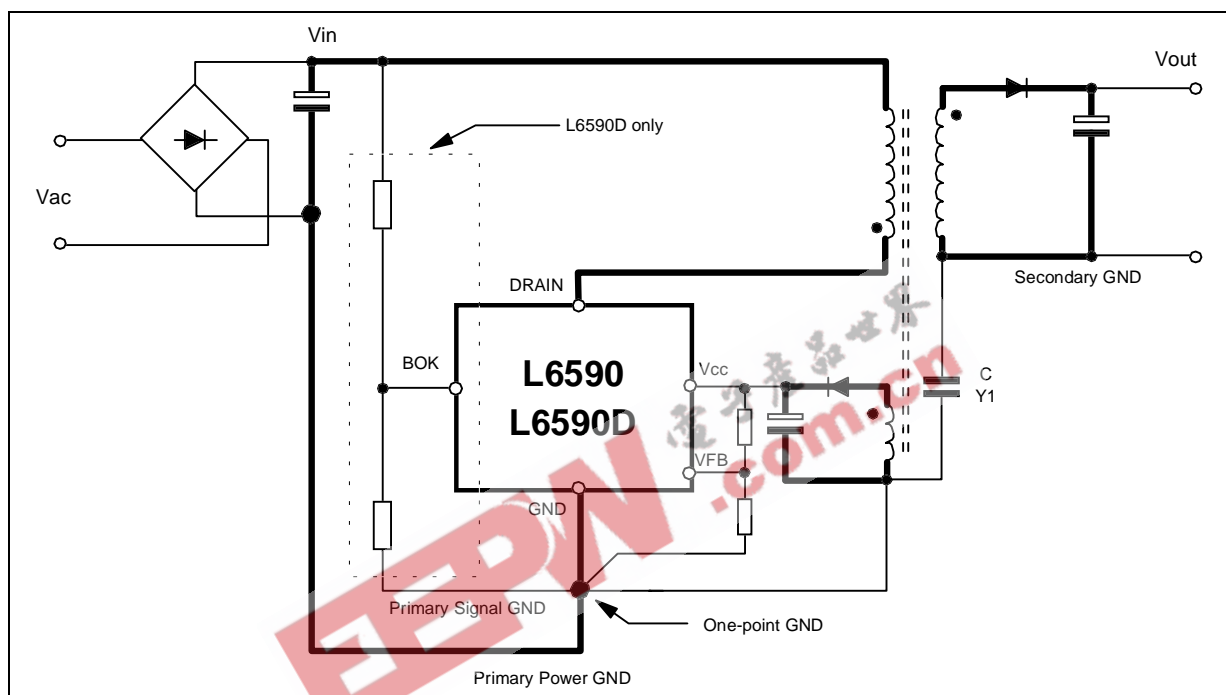

Current returns (or ground) routing is also very important. All of them (signal ground, power ground, shielding, etc.) should be routed separately and should be connected only at a single ground point, as suggested in figures 18 and 19.

Generally, traces carrying signal currents should run far from others carrying pulsed currents or with quickly swinging voltages like the bolded ones of figures 18 and 19. From this viewpoint, particular care should be taken of the feedback path. In case of two layer PCB, it is a good practice to route signal traces on one PCB side and power traces on the other side.

Some crucial points of the circuit need or may need filtering, such as the V_{CC} pin or the BOK pin. In case, high-frequency filter capacitors (with plastic film or ceramic dielectric) should be placed between these pins and the "signal ground" route, as close to the IC as possible.

Reduction of common mode emissions requires a Y1 class capacitor (or two series connected Y2 class ones) connected between the primary and secondary ground. This decoupling capacitor should be connected as close to the transformer as possible.

Another important point is related to creepage distance: this must be observed between primary and secondary ground (8mm), between the phases of the input voltage (4 mm) and the opposite ends of the primary winding of the transformer (4mm). Concerning the primary-to-secondary ground separation, no component or traces

must be placed in this region, except the above mentioned common mode suppression capacitor and any optocoupler for secondary feedback.

Filling any unused space in the PCB with a ground plane helps reduce noise emission, but does not exempt from using the above mentioned care in component placing and traces routing. For instance, if a signal ground is connected to a ground plane along a pulsed current path between two components, (it is usually the most direct one) noise will be injected into the signal circuitry.

Figure 20. Possible component placement.

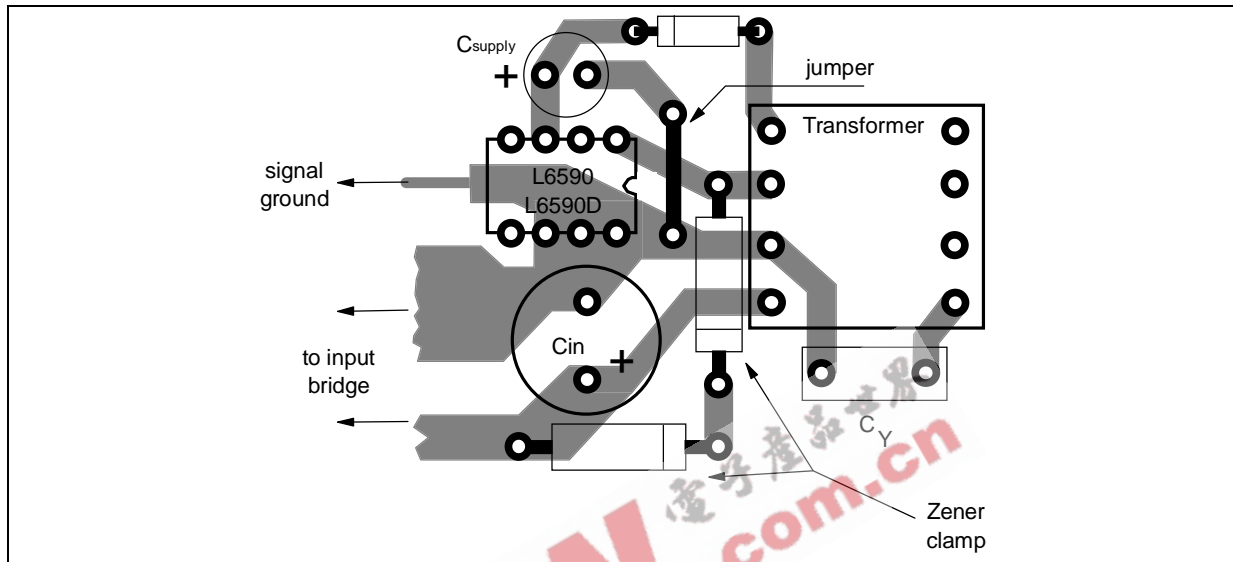

19 TEST BOARD: DESIGN AND EVALUATION

In order to show how to proceed with the design of an application based on the L6590 family, the design of the test board, used to evaluate the device's performance, will be illustrated in details. Finally, the resulting electrical schematic and a bench evaluation of the test board will be presented. The electrical specifications of the test board and some preliminary choices are listed in table 22. Table 23a) shows the results of some preliminary calculations needed to go further with the design steps.

Table 22. Test board's electrical specification and pre-design choices

Electrical Specification		
V_{ACmin}	88 V	Minimum mains voltage
V_{ACmax}	264 V	Maximum mains voltage
f_L	60 Hz	Mains frequency (@ min. mains)
N_H	0	Number of holdup cycles
V_{out}	5 V	Regulated output voltage
$\Delta V_{out\%}$	2 %	Percent output voltage tolerance (\pm)
$V_r\%$	1 %	Percent output voltage ripple
P_{outmax}	10 W	Maximum output power
η	0,75	Expected converter efficiency
T_{amb}	40 °	Maximum ambient temperature

AN1262 APPLICATION NOTE

Table 22. (continued)

Pre-design Choices		
V_R	120 V	Reflected voltage
η_T	0,9	Transformer efficiency
V_{spike}	80 V	Leakage inductance overvoltage
V_{CC}	12 V	L6590 supply voltage
V_F	0.6 V	Secondary diode forward drop
V_{BF}	3 V	Bridge Rectifier + EMI filter voltage drop

Bridge rectifier selection.

An integrated bridge (DF06M, 4x1A/600V, GI) has been selected.

Input Bulk Capacitor.

From table 5, in order for the valley voltage on the input cap to be around 90 V, a minimum capacitance of about 27 μF should be used. A standard 22 $\mu\text{F}/400\text{V}$ electrolytic capacitor will be chosen. After few iterations, the (1) cycle converges at $V_{inmin} = 84.9\text{V}$, $T_C = 2.11 \text{ ms}$. From eqn. 2, $V_{DCmin} = 103.2 \text{ V}$.

Table 23b) shows the results of a second step of calculations, aimed at checking that no limit of the device is violated. The result is OK.

Operating conditions @ $V_{in} = V_{DCmin}$ and thermal check.

The results are listed in table 23c). With these data the power dissipated by the L6590 is calculated and the result is shown in table 23d).

From eqn. 3, the maximum junction-to-ambient thermal resistance needed for reaching thermal balance at $T_j = 125 \text{ }^\circ\text{C}$ is $51.2 \text{ }^\circ\text{C/W}$. From the diagrams of fig. 21 it is possible to see that this can be obtained with about 1 cm^2 copper area on the PCB.

Figure 21. L6590 Family Packages Junction-to-Ambient Thermal Resistance

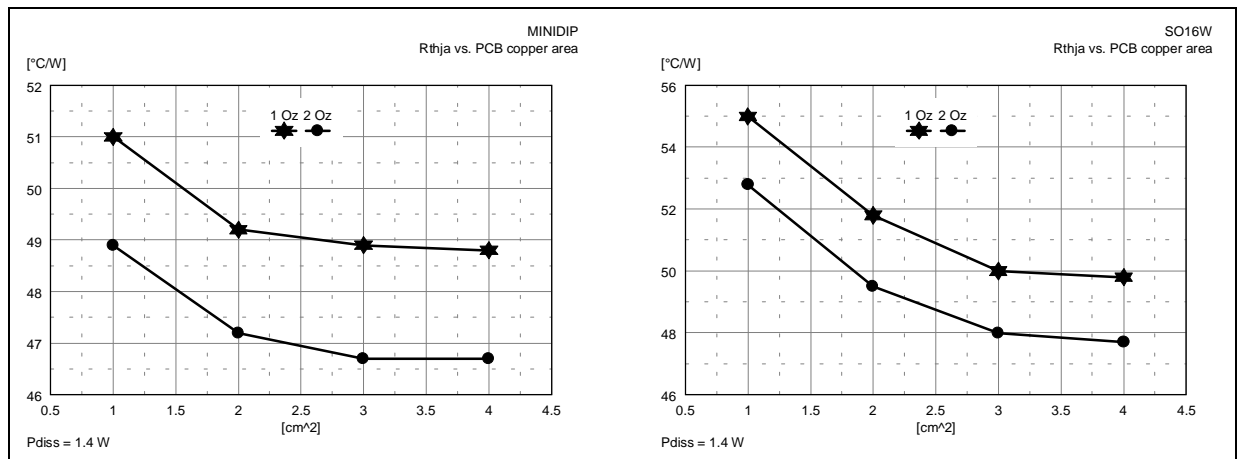

Table 23. Test Board design calculations results.

a) Preliminary Calculations results (step 1)		
Symbol	Parameter	Value
P_{in}	Converter Input Power	13.33 W
I_{out}	DC Output Current	2 A
V_{PKmin}	Minimum Peak Input Voltage	121.5 V
V_{PKmax}	Maximum Peak Input Voltage	373.4 V
b) Preliminary Calculations results (step 2)		
V_{inmin}	Absolute minimum Input DC Voltage	84.9 V
V_{DCmin}	Minimum Input DC bus Voltage	103.2 V
P_{inT}	Transformer Input Power	12.44 W
$V_{DS(on)x}$	Max. average drop on $R_{DS(on)}$ in ON-state	7.24 V
D_x	Maximum Duty Cycle	0.607
V_{DSmax}	Maximum drain Voltage in OFF-state	573.4 V
I_{ppkx}	Max. Peak Primary Current	0.528 A
c) Operating Conditions @ $V_{in} = V_{DCmin}$		
$V_{DS(on)}$	Average drop on $R_{DS(on)}$ in ON-state	7.24 V
D	Duty Cycle (switch ON-time to switching period ratio)	0.496
I_{ppk}	Peak Primary Current	0.528 A
I_{pDC}	DC Primary Current	0.131 A
I_{PRMS}	Total RMS Primary Current	0.215 A
I_{pAC}	RMS Primary Current (AC component only)	0.170 A
D'	Secondary diode conduction time to switching period ratio	0.397
I_{Spk}	Peak Secondary Current	10.08 A
I_{SDC}	DC Secondary Current	2 A
I_{SRMS}	Total RMS Secondary Current	3.67 A
I_{sAC}	RMS Secondary Current (AC component only)	3.08 A
d) Device power dissipation @ $V_{in} = V_{DCmin}$		
P_{cond}	Conduction losses	1.29 W
P_{sw}	Switching losses	0.13 W
P_{cap}	Capacitive losses	0.16 W
P_q	Quiescent losses	0.08 W
P_{tot}	Total losses	1.66 W
$R_{thj-amb}$	Maximum junction-ambient thermal resistance	51.2 °C/W

Flyback transformer design

Eqn. 4 gives the primary inductance ($L_p = 1.37$ mH, rounded up to 1.4 mH), while eqn. (5) gives the primary-to-secondary turns ratio ($n = 21.4$). The design will be done considering Philip's E-cores in 3C85 ferrite and assuming a maximum peak flux of 0.25T, a temperature rise of 40 °C and 40% window utilization factor. Going step-by-step:

- 1) Eqn. 6 provides a minimum AP of 0.042 cm⁴. Table 10 shows that an E20/10/6 core could fit the design.
- 2) The primary turns number will be $N_{pmin} = 122.5$.
- 3) The resulting secondary turn number will be $122.5/21.4=5.7$ which will rounded up to 6. The primary turns number will then become $6 \cdot 21.4=128.4$. Finally, the choice will be $N_p=128$ turns and $N_s=6$ turns, which yields an actual turns ratio of $128/6 = 21.33$, very close to the target.
- 4) From eqn. 7, the air gap needed to get the desired value of L_p will be 0.63 mm.
- 5) Table 10 shows that the thermal resistance of the finished core is 46 °C/W, thus the maximum power dissipation inside the transformer shall not exceed $40/46 = 0.87$ W.
- 6) Equations 8, 9 and 10 will provide the actual flux swing (which will be lower than 0.25 T because $N_p > N_{pmin}$), the actual core losses and the allowed copper losses respectively. The resulting flux swing is $\Delta B=180$ mT: the relevant core losses amount at 66 mW, thus it is possible to dissipate up to 0.8 W in the windings.
- 7) The required primary and secondary winding resistance will be 8.65 Ω and 30 m Ω respectively (resulting from eqns. 11). The resulting primary resistance is quite high and the drop across it reduces significantly the actual voltage applied at the primary inductance. The target primary resistance is then reduced at 4 Ω and the secondary will be increased at 46m Ω to maintain the same total copper losses.

The required primary and secondary copper area will be $2.87 \cdot 10^{-4}$ cm² and $1.2 \cdot 10^{-3}$ cm² respectively (eqns. 12, 13). Table 11 shows that this can be done with one AWG32 wire at the primary and four paralleled (twisted) AWG32 wires at the secondary. This will both minimize high frequency effects and simplify the BOM. The total occupied area will be 7 mm² (eqn. 14), 20% of the total available area, thus the windings will fit.

On top of the primary and secondary winding, 14 turns of AWG32 wire will be wound to make the auxiliary winding (eqn. 15).

- 8) The actual resistance of the primary and secondary windings will be 3.6 Ω and 42 m Ω respectively, for total copper losses of 0.73 W. The total losses will be about 0.8 W and the resulting temperature rise 36.8 °C.

Zener clamp

To optimize losses at light load a zener clamp will be used. The clamp voltage should be around 200 V (eqn. 16), thus a BZW06-154 is first selected.

Assuming a leakage inductance of 30 μ H (about 2% of the primary inductance), power dissipation will be about 0.6 W in normal operation and about 1.1 W in overcurrent limitation. The relevant clamping voltages would be 196 V and 209 V respectively. The initial choice will then be confirmed.

An STTA106 (1A / 600V turboswitch diode) will be used as the blocking diode.

Secondary rectifier

According to eqn. 17, and considering 25% margin, the blocking voltage of the diode should exceed 28 V, while its current rating should be in excess of 4 A. Although table 14 suggests a bigger device, an 1N5822 (3A/40V) Schottky diode is selected for this test board.

Output Capacitor

Capacitor's ripple current rating should exceed 3 A. The minimum capacitance value should be 373 μF (eqn. 18) and the maximum ESR should be less than 5 $\text{m}\Omega$. For long-time reliability the capacitor(s) should also be able to withstand at least 3.08 A current ripple. Three Rubycon's ZL series 470 $\mu\text{F}/16\text{V}$ paralleled capacitors were selected, for a total ripple capability of nearly 3 A and a total ESR of about 20 $\text{m}\Omega$. To meet the requirement on the output voltage ripple an LC post filter is needed that attenuates ripple at least four times. Choosing a standard value of $L = 4.7 \mu\text{H}$, the maximum ESR of the additional capacitor should not exceed 300 $\text{m}\Omega$. An additional 220 $\mu\text{F}/10\text{V}$ ZL capacitor has been added.

Self-supply circuit

The self supply circuit will include an 1N4148 diode and a 22 μF supply capacitor. A 10 Ω resistor will be added in series to the diode to reduce V_{CC} voltage variations with the load current. This value is likely to be adjusted after bench verification.

Control loop design

The crossover frequency will be selected as high as 10 kHz, worst case. The objective will be to get 70° phase margin.

The plant transfer function is:

$$G_2(j\omega) = G_{2_0} \cdot \frac{1 + \frac{j\omega}{\omega_{\text{ESR}}}}{1 + \frac{j\omega}{\omega_{\text{out}}}}$$

with $G_{2_0} = 11.5$, $f_{\text{ESR}} = 5464 \text{ Hz}$, $f_{\text{out}} = 90.3 \text{ Hz}$ (@ max. load and max. V_{in}). A type 2 amplifier will be used for $G_1(j\omega)$.

Going step-by-step:

- The gain and phase of G_2 at $f = 10 \text{ kHz}$ are 0.281 and -29° respectively;
- In order for the overall open-loop gain to cross the 0 dB axis at $f = 10 \text{ kHz}$ with 70° phase margin, the gain and phase of $G_1(j\omega)$ will be 3.56 and -81° respectively;
- the compensating zero will be placed at 360 Hz ($\alpha = 4$, to maximize 100Hz gain);
- the compensating pole will be placed at 2270 Hz;
- the unity gain factor is $35.4 \cdot 10^4 \text{ s/rad}$.

Since a tight tolerance on the output voltage is required, an optoisolated feedback will be used and $G_1(j\omega)$ will be realized with the schematic of figure 13. The TL431 and an optocoupler PC817A from Sharp will be used. The CTR is specified between 0.8 and 1.6.

Using a 6.8k Ω resistor as R_C , the resulting part values are:

$$R_L = R_H = 2.43 \text{ k}\Omega; R_B = 560 \Omega; R_F = 2\text{k}\Omega; C_F = 100 \text{ nF}; C_{\text{COMP}} = 22 \text{ nF}.$$

Electrical Schematic, BOM and evaluation results

In fig. 22 the electrical schematic of the test board is illustrated and table 24 lists the relevant BOM. The diagrams of figure 23 show the evaluation results of the board, figure 24 shows some typical waveforms and figure 25 the effect of the frequency change on the output voltage transient.

AN1262 APPLICATION NOTE

Figure 22. Test board electrical schematic

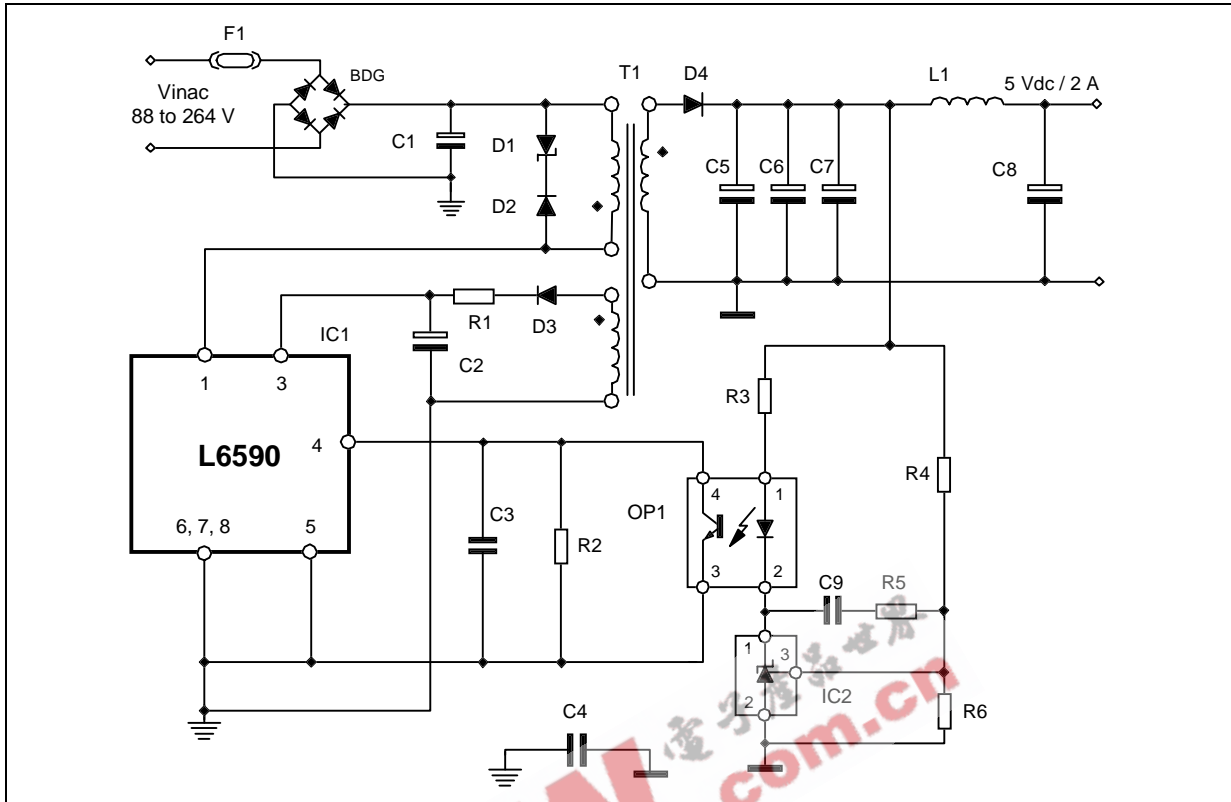

Table 24. Test board Bill Of Material

Symbol	Value	Notes
R1	10 Ω	¼ W, 5%
R2	6.8kΩ	¼ W, 1%
R3	560Ω	¼ W, 1%
R4, R6	2.43kΩ	¼ W, 1%
R5	2kΩ	¼ W, 1%
C1	22 µF	400 V, electrolytic, ELNA RE3 or equivalent
C2	22 µF	25 V, electrolytic
C3	22 nF	plastic film
C4	2.2 nF	250V Y class
C5, C6, C7	470 µF	16 V, electrolytic, RUBYCON ZL or equivalent
C8	220 µF	10 V, electrolytic, RUBYCON ZL or equivalent
C9	100 nF	10V electrolytic
L1	4.7 µH	UK ltd., ELC8D4R7E
D1	BZW06-154	154V / 600W peak Transil, ST

Table 24. (continued)

Symbol	Value	Notes
D2	STTA106	1A / 600V Turboswitch, ST
D3	1N4148	
D4	1N5822	3A / 40V Schottky, ST
IC1	L6590	Monolithic HV Switcher, ST
OP1	PC817A	Optocoupler, Sharp
BD1	DF06M	GI, or equivalent 1A, 600 V
T1	---	Core E20/10/6, 3C85 ferrite, Philips or equivalent ≈ 0.6 mm air gap for a primary inductance of 1.4 mH ($L_{LK} < 30 \mu\text{H}$) Pri: 64T+64T, series connected, AWG32 ($\varnothing 0.22$ mm) Sec: 6T, 4xAWG32 ($\varnothing 0.22$ mm) Aux: 14T, AWG32 ($\varnothing 0.22$ mm)
F1	T2A250V	2A, 250V ELU

Figure 23. Test board evaluation results

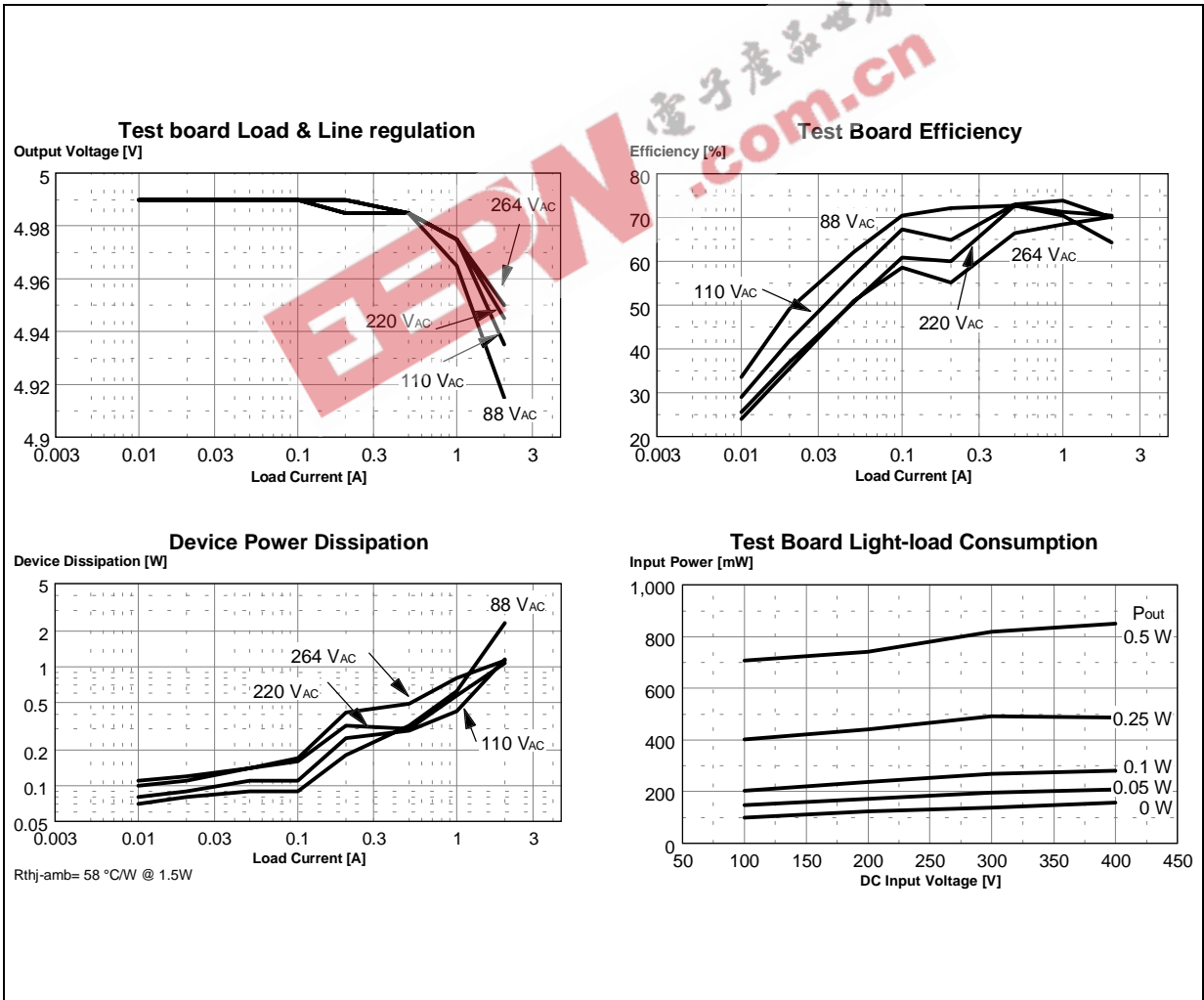

AN1262 APPLICATION NOTE

Figure 24. Test board main waveforms under different operating conditions

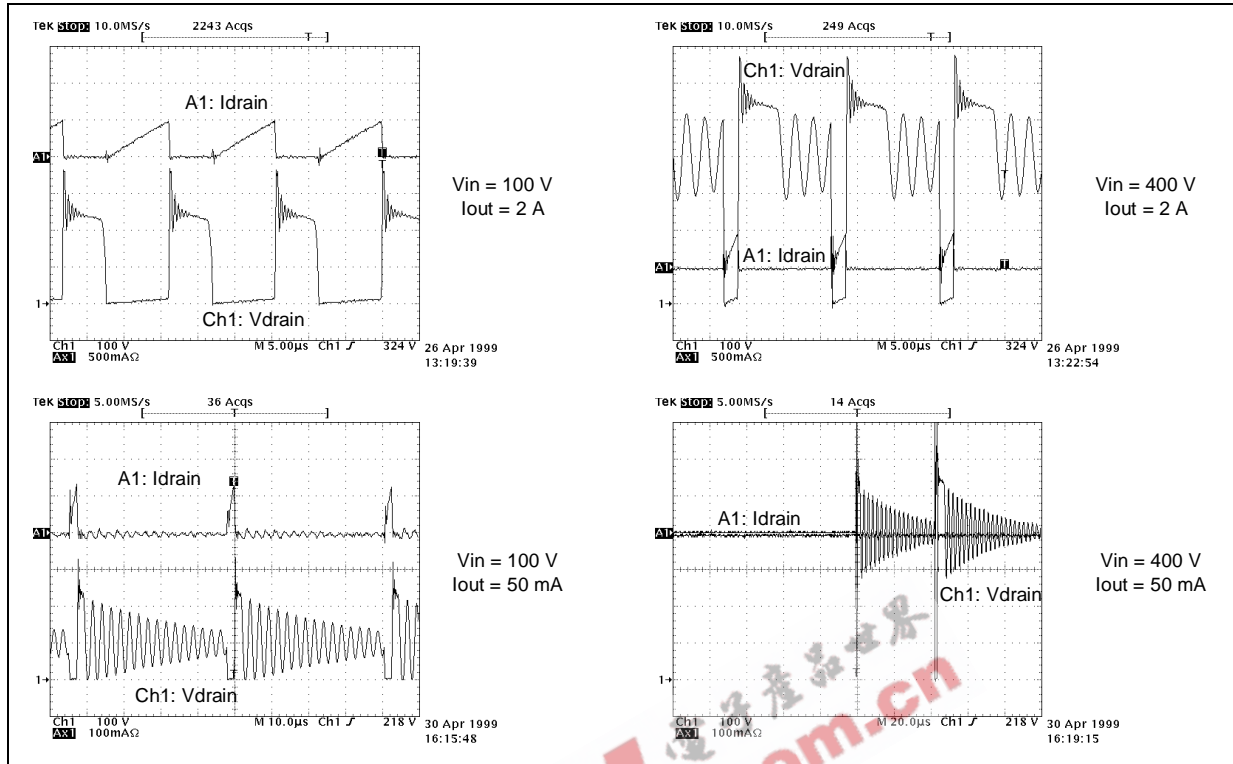
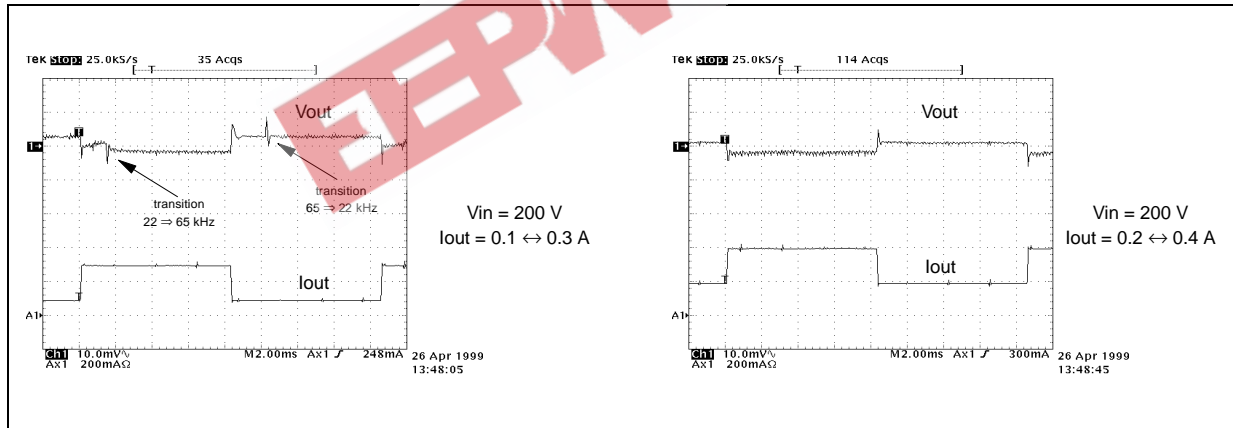

Figure 25. Test board load transient response; effect of frequency change (left).



20 REFERENCES

- [1] Lloyd H. Dixon, Jr. "Filter Inductor and Flyback Transformer Design for Switching Power Supplies", UNI-TRODE Power Supply Design Seminar Manual, 1994 (SEM-1000)
- [2]"Calculation of Transil Apparent Dynamic Resistance" (AN575)
- [3]"Transistor Protection by Transil" (AN587)
- [4]"Getting Familiar with the L6590 Family High-voltage Fully Integrated Power Supply" (AN1261)

SUMMARY

- 1 Flyback Basics 1
- 2 Converter Electrical Specification 3
- 3 Pre-design Choices 3
- 4 Preliminary Calculations (step 1) 5
- 5 Bridge rectifier selection 5
- 6 Input Bulk Capacitor selection 6
- 7 Preliminary Calculations (step 2) 7
- 8 Operating Conditions @ $V_{in} = V_{DCmin}$ 8
- 9 Flyback Transformer design 10
- 10 Clamp Circuit design 16
- 11 Secondary rectifier selection 18
- 12 Output Capacitor selection and post filter 18
- 13 Self-supply Circuit design 20
- 14 Brownout Protection design (L6590A and L6590D only) 20
- 15 Control loop design 21
- 16 Secondary feedback implementation 24
- 17 Primary feedback implementation 30
- 18 Layout Recommendations 31
- 19 Test Board: Design and Evaluation 33
- 20 References 40

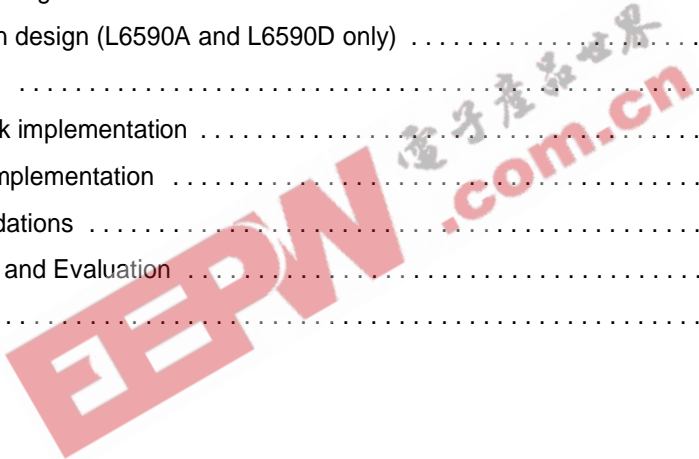

EEPW 电子產品世界
.com.cn

Information furnished is believed to be accurate and reliable. However, STMicroelectronics assumes no responsibility for the consequences of use of such information nor for any infringement of patents or other rights of third parties which may result from its use. No license is granted by implication or otherwise under any patent or patent rights of STMicroelectronics. Specifications mentioned in this publication are subject to change without notice. This publication supersedes and replaces all information previously supplied. STMicroelectronics products are not authorized for use as critical components in life support devices or systems without express written approval of STMicroelectronics.

The ST logo is a registered trademark of STMicroelectronics
© 2001 STMicroelectronics - All Rights Reserved

STMicroelectronics GROUP OF COMPANIES
Australia - Brazil - China - Finland - France - Germany - Hong Kong - India - Italy - Japan - Malaysia - Malta - Morocco - Singapore - Spain
- Sweden - Switzerland - United Kingdom - U.S.A.
<http://www.st.com>