

USB Series "Mini-AB" Connectors CAM-E43ASF · E43ADF · E43SDF

FEATURES

1. Ultra-small size realized for 5 pins.
Volume as compared to conventional Mitsumi product : 1/5
Coupling projection area ratio : 1/4
2. It is the most suitable for connection with PC peripheral equipment with slim PCs, PDAs, mobile phones and so on.
3. Utilizes a sequential function that slides power supply and signal contact connection timing.
4. Couple/decouple reliability ensured for 5,000 times.
5. Weight : 0.6g
6. Supports USB 2.0 (on-the-Go).

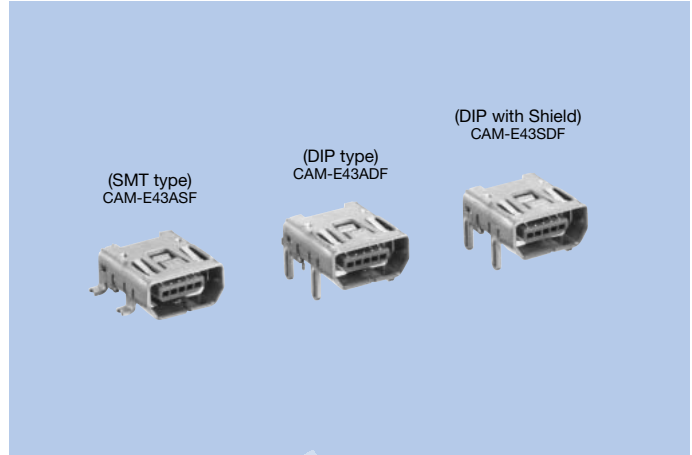

HOW TO ORDER

1. CAM-E43ASF

E43ASF-005-7013A

1 2 3

- 1 Series No. (E43ASF)
- 2 No. of contacts (005 : 5pins)
- 3 Running No. assigned by us

2. CAM-E43ADF

E43ADF-005-9024A

1 2 3

- 1 Series No. (E43ADF)
- 2 No. of contacts (005 : 5pins)
- 3 Running No. assigned by us

3. CAM-E43SDF

E43SDF-005-8555A

1 2 3

- 1 Series No. (E43SDF)
- 2 No. of contacts (005 : 5pins)
- 3 Running No. assigned by us

SPECIFICATIONS

ELECTRICAL CHARACTERISTICS

Rated Voltage	AC 5V (rms)
Rated Current	1.0A
Withstanding Voltage	AC 100V (rms) 1minute
Insulation Resistance	100MΩ min. (AC500V)
Contact Resistance	50mΩ max.

MECHANICAL CHARACTERISTICS

Life (Matching Cycle)	5,000 times
Total Insertion Force	35N (3.57kgf) max.
Total Withdrawal Force	Beginning 7N (0.71kgf) min. After 5,000 times 3N (0.31kgf) min.

MATERIAL & FINISH

Component Parts	Material	Finish
Housing	Thermo plastic	(Gray)
Contact	Copper Alloy	Gold plating
Shield Case	Copper Alloy	Tin reflow plating

DIMENSIONS

CAM-E43ASF

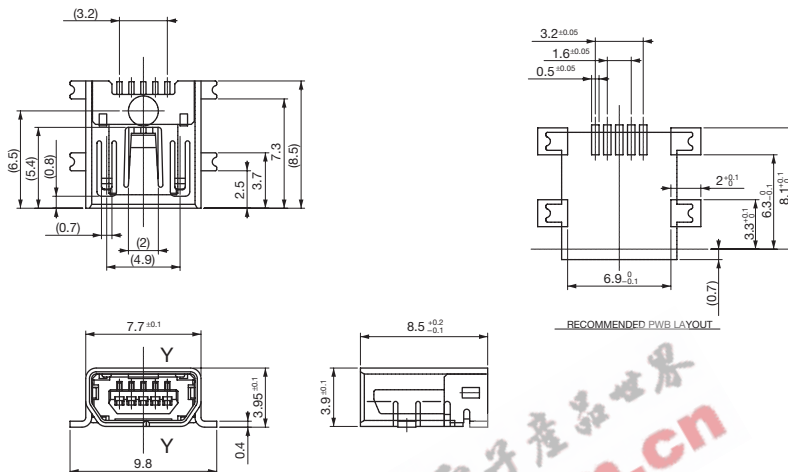

Unit : mm

CAM-E43ADF

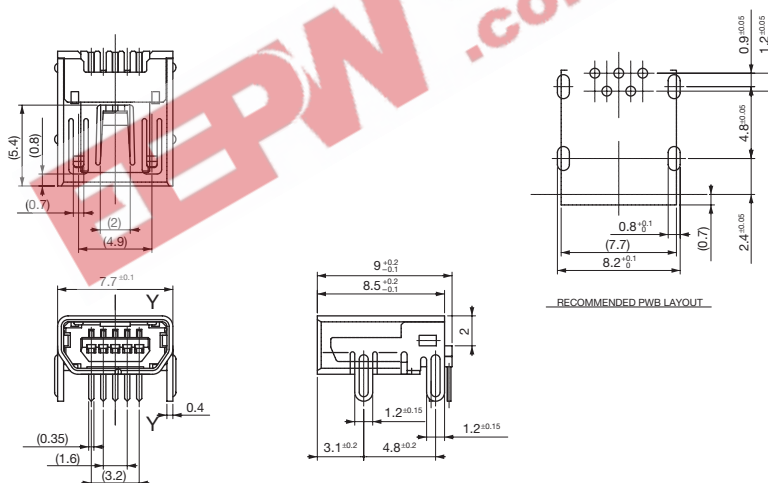

Unit : mm

CAM-E43SDF

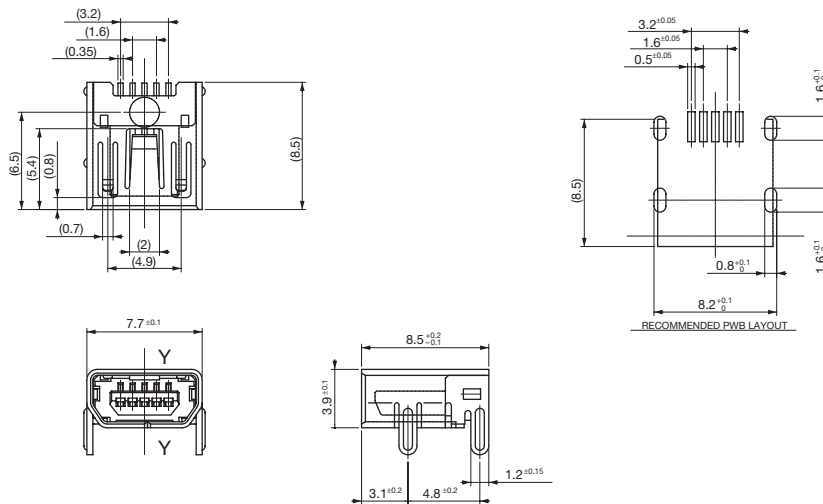

Unit : mm