

#### DESCRIPTION:

The KWA-2001 series is 2.00 inch (50.80mm) height 16-segment single digit alphanumeric displays with the right DP. This series is suitable for use in instrument panels, digital readout displays. All devices are available as either common anode or common cathode.

#### ABSOLUTE MAXIMUM RATINGS: (Ta=25°C)

| Parameter  | Max            |
|--|----------------|
| Reverse Voltage per segment                                      | 5 V            |
| Reverse Current per segment (Vr = 5V)                            | 100μA          |
| Derating Linear from 25°C per segment                            | 0.4mA/°C       |
| Operating Temperature Range                                      | -40°C To 85°C  |
| Storage Temperature Range  | -40°C To 100°C |
| Soldering Temperature 1.6mm(1/16") from body for 5 sec. at 260°C |                |

- NOTES : 1. All dimensions are in millimeters (inches).  
 2. Tolerance is ±0.25mm(0.010) unless otherwise specified.  
 3. Specifications are subject to change without notice.  
 4. NP: No Pin.  
 5. NC: No Connect.

#### TESTING CONDITION FOR EACH PARAMETER :

| Parameter                  | Symbol | Unit | Test Condition |
|----------------------------|--------|------|----------------|
| Forward Voltage            | Vf     | V    | If=20mA        |
| Peak Emission Wave Length  | λp     | nm   | If=20mA        |
| Spectral Line Half-Width   | Δλ     | nm   | If=20mA        |
| Reverse Current            | Ir     | μA   | Vr=5V          |
| Average Luminous Intensity | Iv     | μcd  | If=10mA        |

#### PACKAGE DIMENSIONS

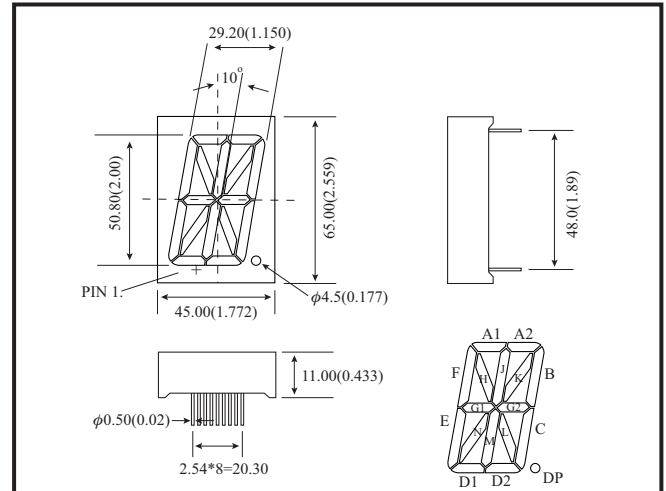

#### INTERNAL CIRCUIT DIAGRAM

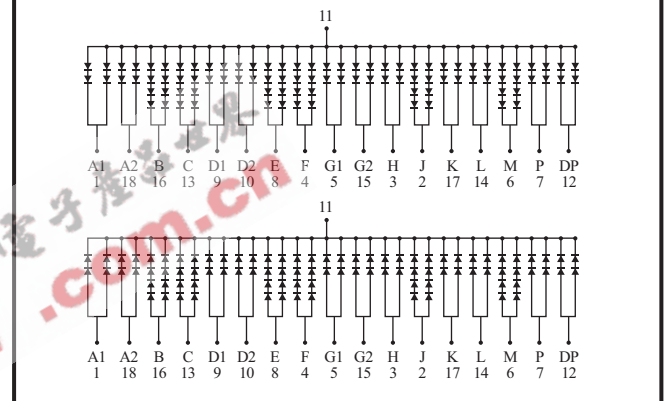

#### PART NO. SELECTION AND APPLICATION INFORMATION (RATINGS AT 25°C AMBIENT)

| Part No.   | Chip         |               | C.C or C.A     | Wave Length λp (nm) | Absolute Maximum Ratings |         |         |                | Electro-optical Data(at 10mA) |      |      |               |                      |       |
|------------|--------------|---------------|----------------|---------------------|--------------------------|---------|---------|----------------|-------------------------------|------|------|---------------|----------------------|-------|
|            | Raw Material | Emitted Color |                |                     | Δλ (nm)                  | Pd (mW) | If (mA) | If (Peak) (mA) | Vf (V) Per Segment            |      |      | If (Rec) (mA) | Iv (μcd) Per Segment |       |
|            |              |               |                |                     |                          |         |         |                | Min.                          | Typ. | Max. |               | Min.                 | Typ.  |
| KWA-2001A3 | GaAsP/GaP    | Hi-Eff. Red   | Common Anode   | 635                 | 45                       | 100     | 50      | 100            | 6.8                           | 9.6  | 10.4 | 10-20         | 2000                 | 6000  |
| KWA-2001AS | GaAlAs       | Super Red     |                | 660                 | 20                       | 100     | 50      | 100            | 6.0                           | 7.6  | 10.4 | 10-20         | 12000                | 42000 |
| KWA-2001A2 | GaP          | Green         |                | 565                 | 30                       | 100     | 50      | 100            | 6.8                           | 9.6  | 10.4 | 10-20         | 1800                 | 5400  |
| KWA-2001AG | GaP          | Super Green   |                | 570                 | 30                       | 100     | 50      | 100            | 6.8                           | 9.6  | 10.4 | 10-20         | 2000                 | 5700  |
| KWA-2001A6 | GaAsP/GaP    | Yellow        |                | 585                 | 30                       | 100     | 50      | 100            | 6.8                           | 9.6  | 10.4 | 10-20         | 1800                 | 5400  |
| KWA-2001C3 | GaAsP/GaP    | Hi-Eff Red    | Common Cathode | 635                 | 45                       | 100     | 50      | 100            | 6.8                           | 9.6  | 10.4 | 10-20         | 2000                 | 6000  |
| KWA-2001CS | GaAlAs       | Super Red     |                | 660                 | 20                       | 100     | 50      | 100            | 6.0                           | 7.6  | 10.4 | 10-20         | 12000                | 42000 |
| KWA-2001C2 | GaP          | Green         |                | 565                 | 30                       | 100     | 50      | 100            | 6.8                           | 9.6  | 10.4 | 10-20         | 1800                 | 5400  |
| KWA-2001CG | GaP          | Super Green   |                | 570                 | 30                       | 100     | 50      | 100            | 6.8                           | 9.6  | 10.4 | 10-20         | 2000                 | 5700  |
| KWA-2001C6 | GaAsP/GaP    | Yellow        |                | 585                 | 30                       | 100     | 50      | 100            | 6.8                           | 9.6  | 10.4 | 10-20         | 1800                 | 5400  |

- REMARKS : 1. The average luminous intensity is obtained by summing the luminous intensity of each segment and dividing by the total number of segments.  
 2. Luminous intensity is measured with a light sensor and filter combination that approximates the CIE (International Commission on Illumination) eye-response curve.  
 3. Clean only by pure water, isopropanol, ethanol, Freon TF (or equivalent).