

ZERO VOLTAGE SWITCH

The KA2804 is a TRIAC controller providing a complete solution for temperature controlled electric panel heaters, cookers, film processing baths etc.

Switching occurs at the zero voltage point in order to minimize radio frequency interference. The device is suitable for mains-on-line operation and requires minimal components.

FEATURES

- Easy operation either through the AC line or a DC supply.
- Supply voltage control.
- Very few external components.
- Symmetrical burst control—No DC current components in the load circuit.
- Negative output current pulse up to 250mA—short circuit protection.
- Reference voltage output.

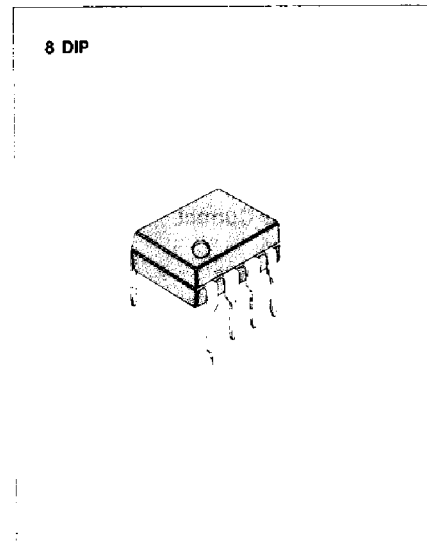

ORDERING INFORMATION

Device	Package	Operating Temperature
KA2804N	8 DIP	-20 - +70°C

BLOCK DIAGRAM

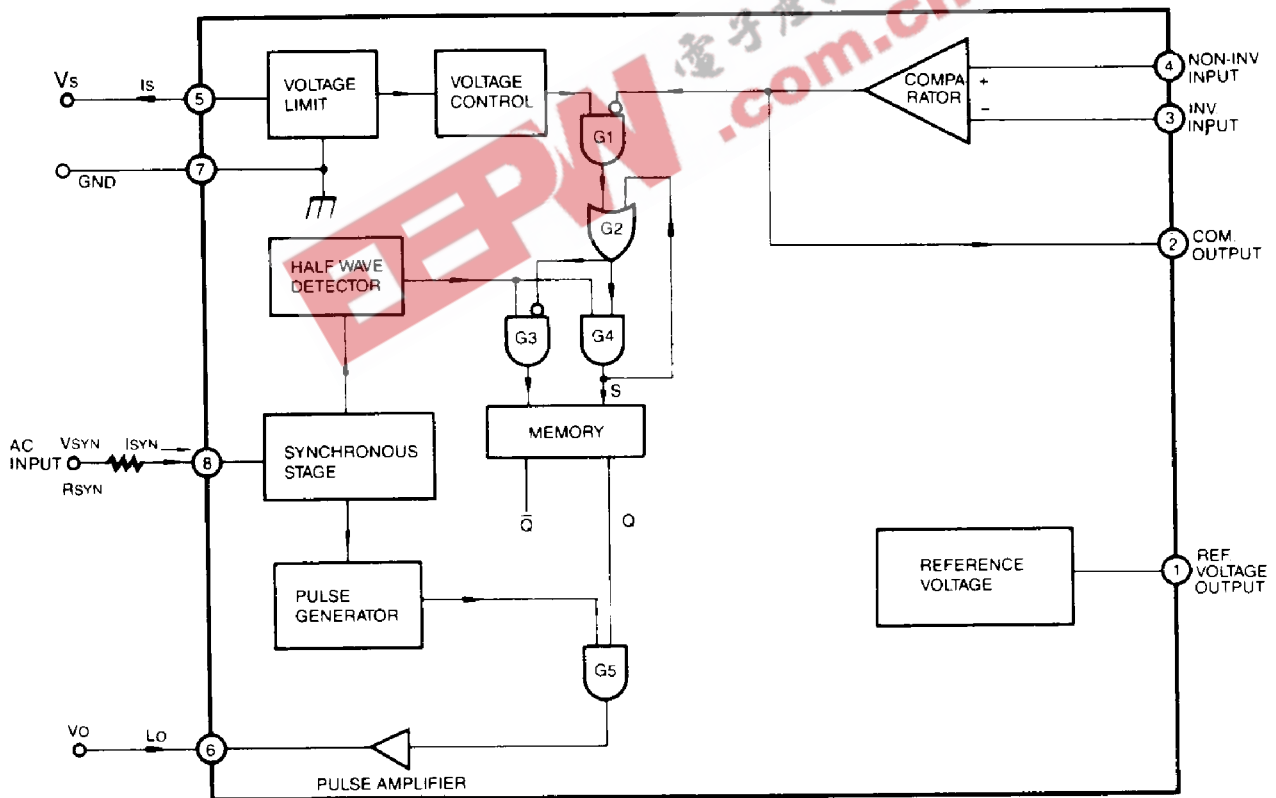

ABSOLUTE MAXIMUM RATINGS ($T_a=25^\circ\text{C}$)

Characteristic	Symbol	Value	Unit
Supply Voltage	$-V_S$	8.2	V
Supply Current	$-I_S$	40 (average)	mA
Synchronous Current	I_{SYN}	5.0 (rms)	mA
Input Voltage	V_I	$\leq V_S $	V
Power Dissipation	P_D	350	mW
Junction Temperature	T_J	125	$^\circ\text{C}$
Operating Ambient Temperature	T_{OPR}	$-20 \sim +70$	$^\circ\text{C}$
Storage Temperature	T_{STG}	$-65 \sim +150$	$^\circ\text{C}$

ELECTRICAL CHARACTERISTICS

($V_S=8.0\text{V}$, $V_{SYN}=100$ to 115V_{rms} , $T_a=25^\circ\text{C}$, $f=50/60\text{Hz}$, unless otherwise specified)

Characteristic	Symbol	Test Conditions	Min	Typ	Max	Unit
Circuit Current	$-I_S$	Pin 5, $R_{SYN}=56\text{K}$	—	2.0	2.5	mA
Supply Voltage 1	$-V_S 1$	Pin 5, $I_S=2.5\text{mA}$ $R_{SYN}=56\text{K}$	7.2	—	8.4	V
Supply Voltage 2	$-V_S 2$	Pin 5, $I_S=20\text{mA}$ $R_{SYN}=56\text{K}$	7.2	—	8.6	V
Synchronous Current	I_{SYN}	Pin 8	0.3	—	—	mA
Output Pulse Width	T_P	Pin 6, $R_{SYN}=56\text{K}$	—	200	—	μs
Output Voltage	V_O	Pin 6, $I_O \leq 200\text{mA}$	4.2	5.2	—	V
Output Current	I_O	Pin 6, $R_O \leq 25$	200	250	—	mA
Output Leakage Current	I_{LO}	Pin 6	—	—	2.0	μA
Input Offset Voltage	V_{IO}	Pin 3, 4	—	2.0	5.0	mV
Input Bias Current	I_I	Pin 3, 4	—	0.5	1.0	μA
Common Mode Input Voltage Range	$-V_{ICM}$	Pin 3, 4	0	—	5.7	V
Output Leakage Current	I_{LC}	Pin 2	—	—	0.2	μA
Reference Voltage	$-V_R$	Pin 1, $I_R \leq 1\mu\text{A}$	—	3.6	—	V

APPLICATIONS

ON-OFF TEMPERATURE CONTROL

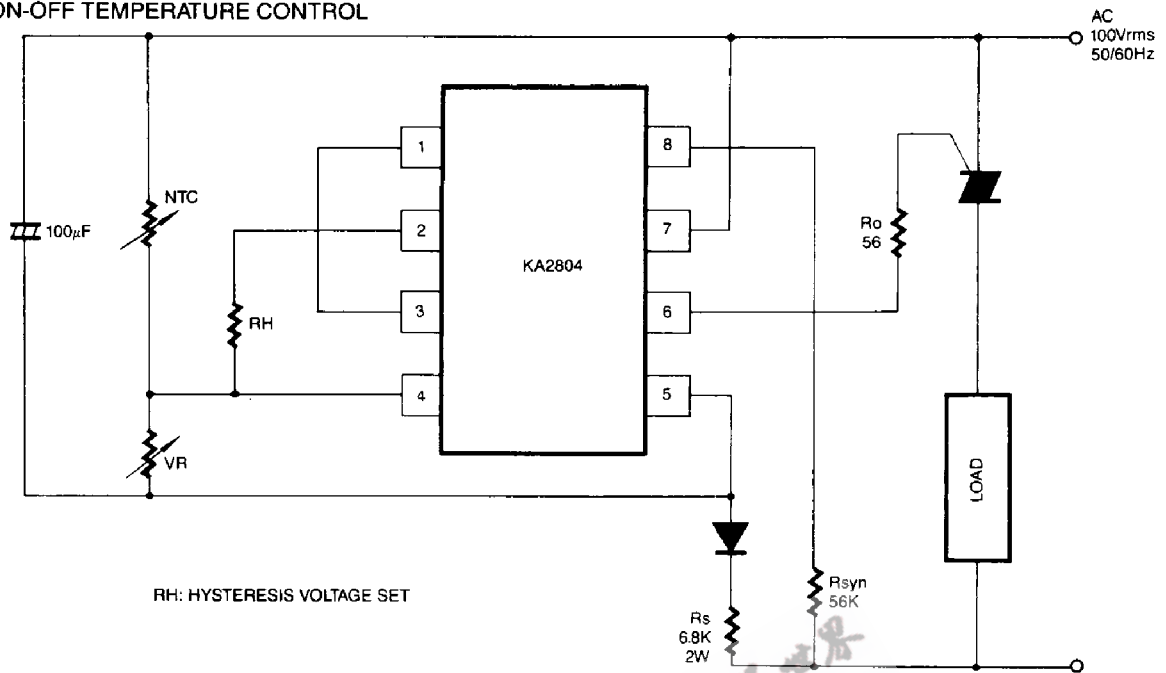

TIME PROPORTIONAL TEMPERATURE CONTROL

