

SILICON BRIDGE RECTIFIERS

REVERSE VOLTAGE - 50 to 1000Volts
FORWARD CURRENT - 4 / 6 / 8 Amperes

FEATURES

- Surge overload rating -150~200 amperes peak
- Ideal for printed circuit board
- Reliable low cost construction utilizing molded plastic technique
- Plastic material has UL
- Mounting position: Any
- Mounting torque: 5 In.lb. Max

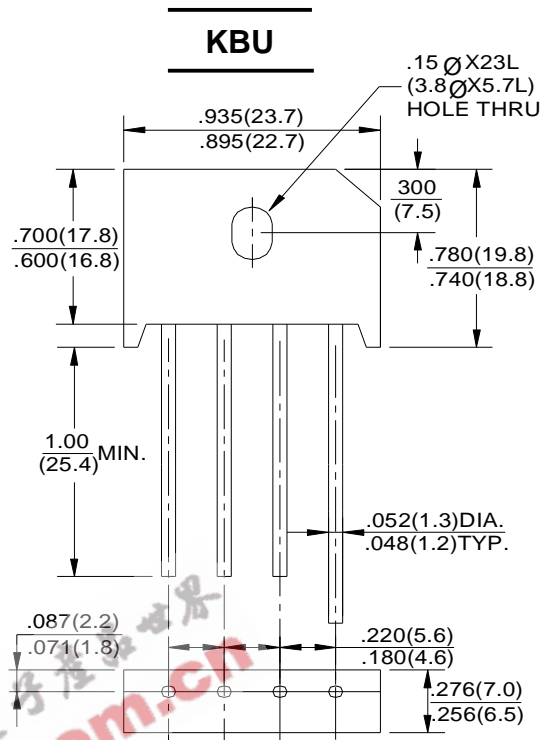

Dimensions in inches and (millimeters)

MAXIMUM RATINGS AND ELECTRICAL CHARACTERISTICS

Rating at 25°C ambient temperature unless otherwise specified.

Single phase, half wave, 60Hz, resistive or inductive load.

For capacitive load, derate current by 20%

CHARACTERISTICS	KBU4005	KBU401	KBU402	KBU404	KBU406	KBU408	KBU410	UNIT
	KBU6005	KBU601	KBU602	KBU604	KBU606	KBU608	KBU610	
	KBU8005	KBU801	KBU802	KBU804	KBU806	KBU808	KBU810	
Maximum Recurrent Peak Reverse Voltage	50	100	200	40	600	800	1000	V
Maximum RMS Voltage	35	70	140	280	420	560	700	V
Maximum DC Blocking Voltage	50	100	200	40	600	800	1000	V
Maximum Average Forward Rectified Output Current at T _c =100°C		4.0		6.0			8.0	A
Peak Forward Surge Current 8.3ms single Half Sine-Wave Super Imposed on Rated Load (JEDEC Method)	KBU4	150	KBU6	175	KBU8		200	A
Maximum Instantaneous Forward Voltage Drop per Element at 4.0A/3.0A/4.0A		1.0		1.0			1.1	mV
Maximum Reverse Leakage at rated DC Blocking Voltage Per Element T _A =25°C		10		10			10	μA
DC Blocking Voltage Per Element T _A =100°C		100		200			300	mA
Operating and Storage Temperature Range T _J .T _{STG}	-55 to +125							°C

FIG.1-DERATING CURVE FOR OUTPUT RECTIFIED CURRENT

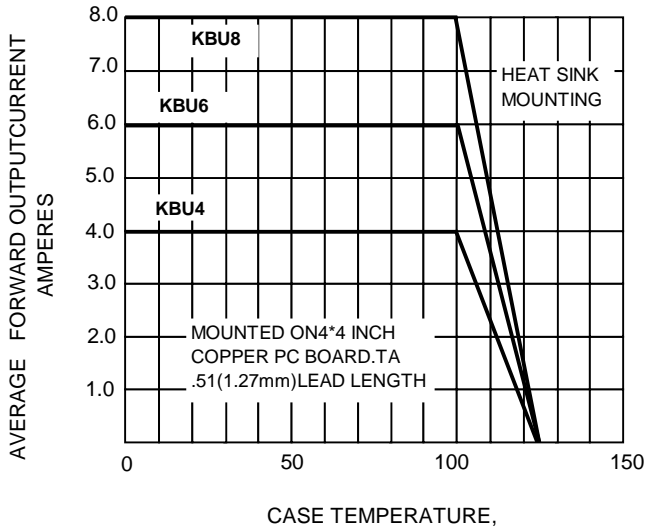

FIG.2 TYPICAL INSTANTANEOUS FORWARD CHARACTERISTIC

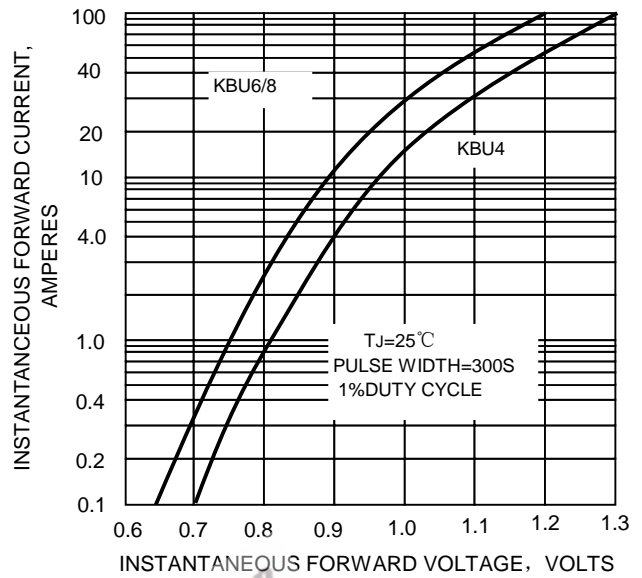

FIG.3-MAXIMUM NON-REPETITIVE PEAK FORWARD SURGE CURRENT

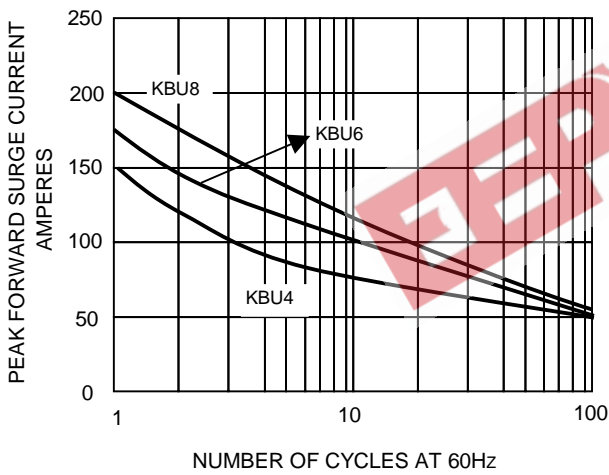

FIG.4-TYPICAL REVERSE CHARACTERISTICS

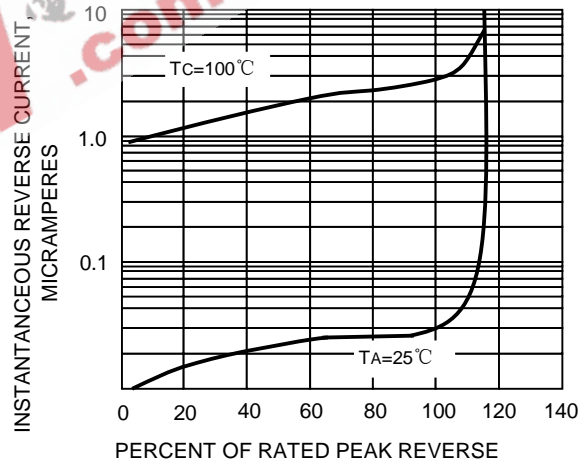

FIG.5-TYPICAL JUNCTION CAPACITANCE PER ELEMENT

