



KBPC6005 THRU KBPC610

SINGLE PHASE GLASS BRIDGE RECTIFIER

Voltage: 50 TO 1000V CURRENT:6.0A

FEATURES

- Surge overload rating: 125A peak
- High case dielectric strength

MECHANICAL DATA

- Terminal:** Plated leads solderable per MIL-STD 202E, method 208C
- Case:** UL-94 Class V-0 recognized Flame Retardant Epoxy
- Polarity:** Polarity symbol marked on body
- Mounting :** Hole thru for #6 screw

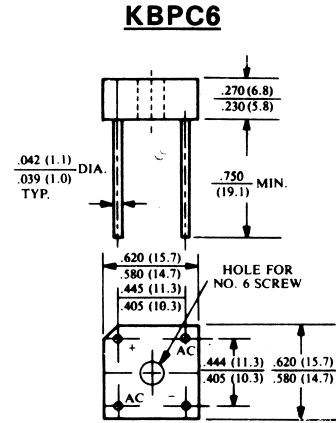

Dimensions in inches and (millimeters)

MAXIMUM RATINGS AND ELECTRICAL CHARACTERISTICS

(Single-phase, half-wave, 60HZ, resistive or inductive load rating at 25°C , unless otherwise stated, for capacitive load, derate current by 20%)

	SYMBOL	KBPC6005	KBPC601	KBPC602	KBPC604	KBPC606	KBPC608	KBPC610	units
Maximum Recurrent Peak Reverse Voltage	V _{rrm}	50	100	200	400	600	800	1000	V
Maximum RMS Voltage	V _{rms}	35	70	140	280	420	560	700	V
Maximum DC blocking Voltage	V _{dc}	50	100	200	400	600	800	1000	V
Maximum Average Forward Rectified current at Ta=75°C	I _{f(av)}	6.0							A
Peak Forward Surge Current 8.3ms single half sine-wave superimposed on rated load	I _{fsm}	125							A
Maximum Instantaneous Forward Voltage at forward current 3.0A DC	V _f	1.0							V
Maximum DC Reverse Voltage Ta=25°C at rated DC blocking voltage Ta=100°C	I _r	10.0							μA
		200							μA
Operating Temperature Range	T _j	-55 to +125							°C
Storage and operation Junction Temperature	T _{stg}	-55 to +150							°C

RATINGS AND CHARACTERISTIC CURVES KBPC6005 THRU KBPC610

FIG.1-MAXIMUM NON-REPETITIVE FORWARD SURGE CURRENT

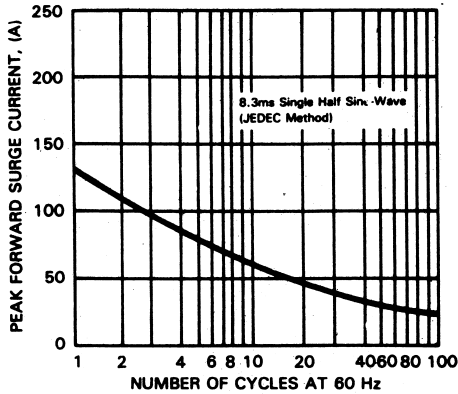

FIG.2-TYPICAL FORWARD CURRENT DERATING CURVE

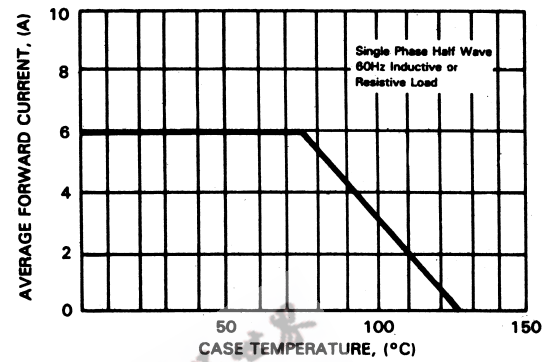

FIG.3-TYPICAL INSTANTANEOUS FORWARD CHARACTERISTICS

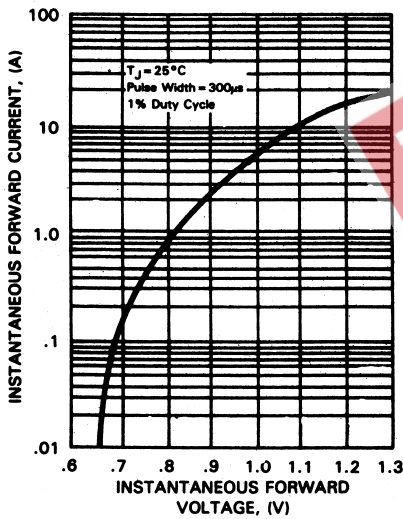

FIG.4-TYPICAL REVERSE CHARACTERISTICS

