



# DATA SHEET

## KBJ2500~KBJ2510

### IN-LINE GLASS PASSIVATED SINGLE-PHASE BRIDGE RECTIFIER

**VOLTAGE** 50 to 1000 Volts **CURRENT** 25 Amperes

#### FEATURES

- Plastic material has Underwriters Laboratory Flammability Classification 94V-O
- Ideal for printed circuit board
- Reliable low cost construction utilizing molded plastic technique
- Surge overload rating : 400 Amperes
- High temperature soldering guaranteed : 260 °C/10 seconds/.375"(9.5mm) lead length at 5 lbs.(2.3kg) tension
- Pb free product are available : 99% Sn above can meet Rohs environment substance directive request

#### MECHANICAL DATA

Case: Reliable low cost construction utilizing molded plastic technique  
 Terminals: Leads solderable per MIL-STD-202G, Method 208  
 Mounting position: Any  
 Mounting torque : 20 in. lb. Max.  
 Weight: 7.056g

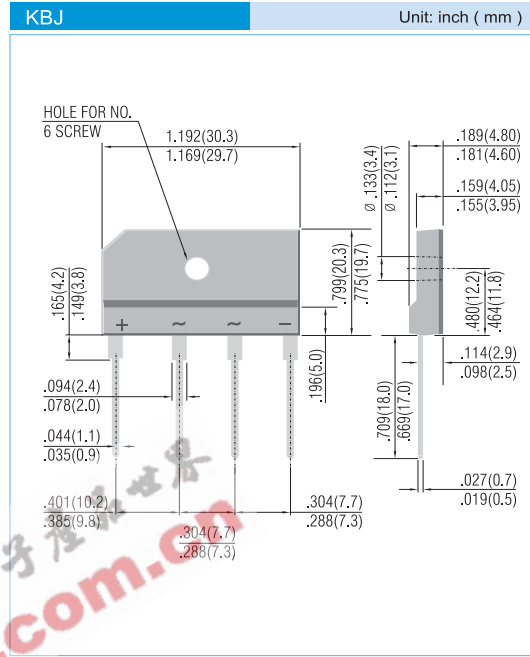

#### MAXIMUM RATINGS AND ELECTRICAL CHARACTERISTICS

Ratings at 25°C ambient temperature unless otherwise specified. Resistive or inductive load, 60 Hz.  
 For capacitive load, derate current by 20%

PARAMETER	SYMBOL	KBJ2500	KBJ2501	KBJ2502	KBJ2504	KBJ2506	KBJ2508	KBJ2510	UNITS	
Maximum Recurrent Peak Reverse Voltage	V <sub>RRM</sub>	50	100	200	400	600	800	1000	V	
Maximum RMS Voltage	V <sub>RMS</sub>	35	70	140	280	420	560	700	V	
Maximum DC Blocking Voltage	V <sub>DC</sub>	50	100	200	400	600	800	1000	V	
Maximum Average Forward Current for Resistive Load at T <sub>c</sub> =55°C	I <sub>AV</sub>	25								A
Non-repetitive Peak Forward Surge Current, Rated Load	I <sub>FSM</sub>	350								A
Maximum Forward Voltage per Bridge Element at 15A Specified Current	V <sub>F</sub>	1.1								V
Maximum Reverse Leakage Current at Rated T <sub>A</sub> =25°C	I <sub>R</sub>	10								μA
Typical Thermal Resistance	R <sub>θJC</sub>	1.2								°C / W
Operating Junction and Storage Temperature Range	T <sub>J</sub> , T <sub>STG</sub>	-50 TO +150								°C

#### NOTES:

1. Device mounted on 100mm\*100mm\*1.6mm Cu plate heatsink.

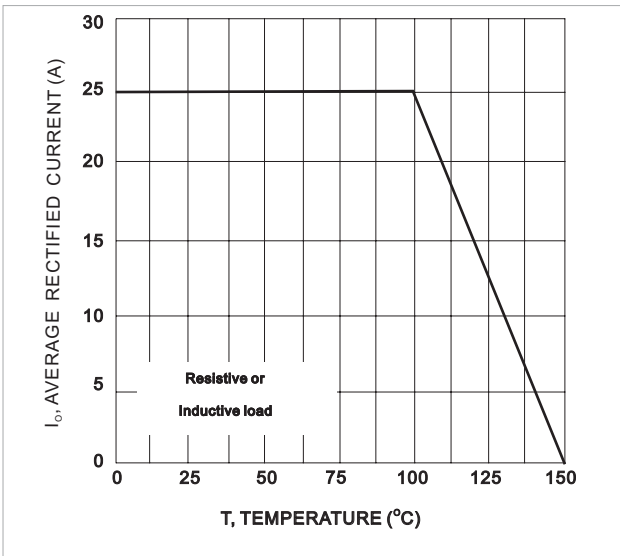

**FIG.1-FORWARD CURRENT DERATING CURVE**

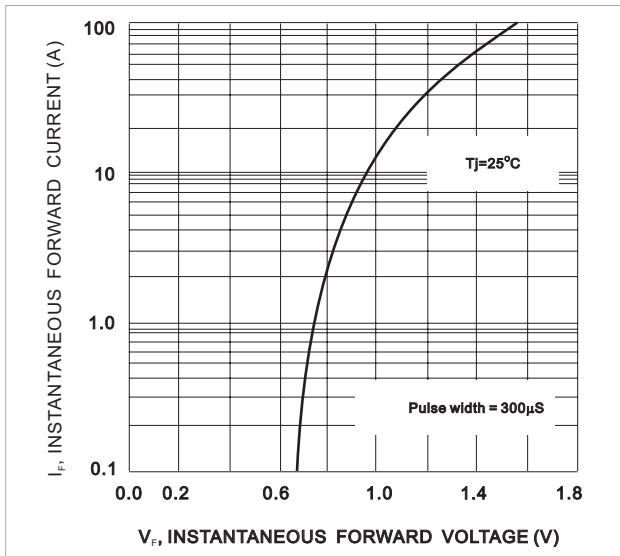

**FIG.2-TYPICAL FWD CHARACTERISTICS, PER ELEMENT**

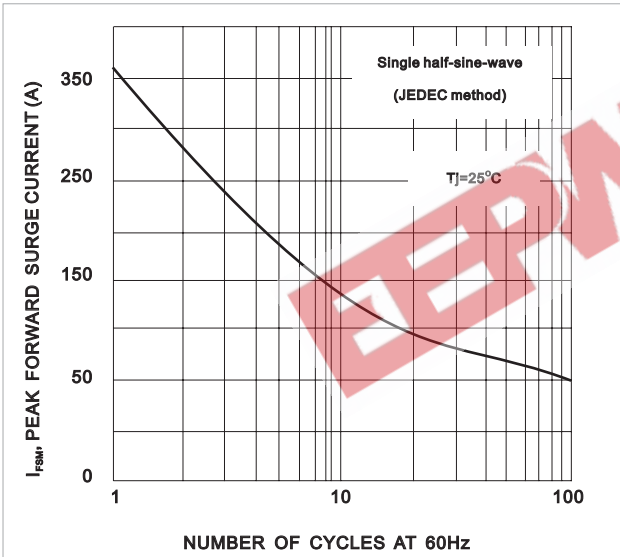

**FIG.3-MAXIMUM NON-REPETITIVE SURGE CURRENT**

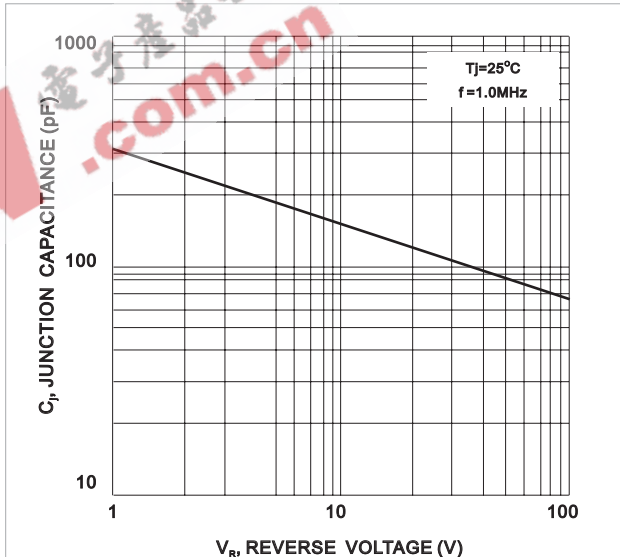

**FIG.4-TYPICAL JUNCTION CAPACITANCE**