



KBPC35005 THRU KBPC3510

**SINGLE PHASE SILICON
BRIDGE RECTIFIER**

**TECHNICAL
SPECIFICATION**

VOLTAGE: 50 TO 1000V CURRENT: 35A

FEATURES

- Surge overload rating: 400A peak
- High case dielectric strength
- 1/4" universal fasten terminal
- and ϕ .04" lead - wire available
- High temperature soldering guaranteed:
250°C/10sec/0.375"(9.5mm) lead length
at 5 lbs tension

MECHANICAL DATA

- Polarity: Polarity symbol marked on body
- Mounting position: Hole thru for #8 screw
- Case: metal or plastic

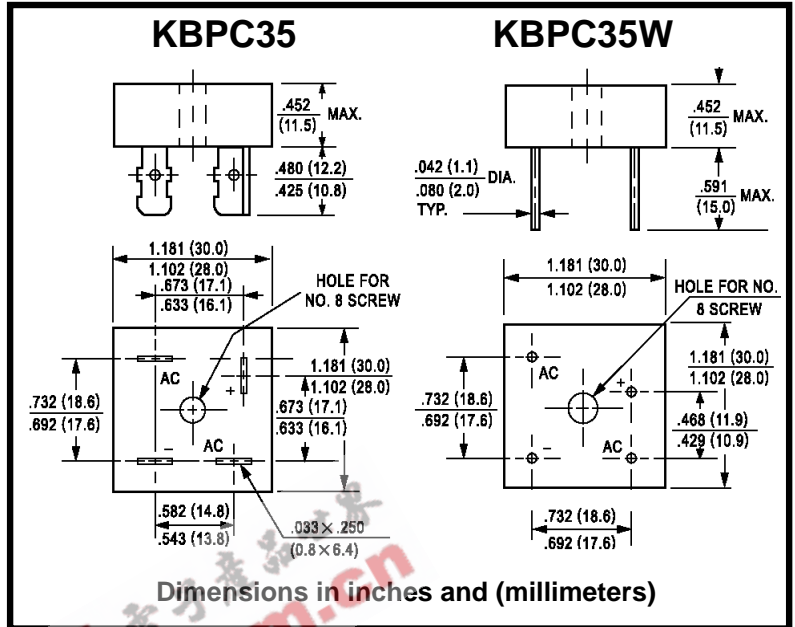

MAXIMUM RATINGS AND ELECTRICAL CHARACTERISTICS

(Single-phase, half-wave, 60Hz, resistive or inductive load rating at 25°C, unless otherwise stated, for capacitive load, derate current by 20%)

RATINGS	SYMBOL	KBPC 35005	KBPC 3501	KBPC 3502	KBPC 3504	KBPC 3506	KBPC 3508	KBPC 3510	UNITS
Maximum Repetitive Peak Reverse Voltage	V_{RRM}	50	100	200	400	600	800	1000	V
Maximum RMS Voltage	V_{RMS}	35	70	140	280	420	560	700	V
Maximum DC Blocking Voltage	V_{DC}	50	100	200	400	600	800	1000	V
Maximum Average Forward Rectified Current ($T_c=55^\circ\text{C}$)	$I_{F(AV)}$	35							A
Peak Forward Surge Current (8.3ms single half sine-wave superimposed on rated load)	I_{FSM}	400							A
Maximum Instantaneous Forward Voltage (at forward current 17.5A DC)	V_F	1.1							V
Maximum DC Reverse Current (at rated DC blocking voltage)	I_R	10.0 500							μA μA
Storage and Operating Junction Temperature	T_{STG}, T_J	-55 to +150							$^\circ\text{C}$

Note:

Suffix "W" for wire type