



## KBJ601G THRU KBJ610G

### CLASS PASSIVATED SINGLE - PHASE BRIDGE RECTIFIERS



**VOLTAGE RANGE**  
50 to 1000 Volts  
**CURRENT**  
6.0 Amperes

#### FEATURES

- \* Plastic Package has Underwriters Laboratory Flammability Classification 94V - 0
- \* Ideal for printed circuit boards
- \* Glass passivated chip junction
- \* High Surge Current Capability
- \* High temperature Soldering Guaranteed  
260°C/10 Seconds, 0.375(9.5mm) lead length

#### MECHANICAL DATA

- \* Case: Moled plastic body over passivated junctions

## KBJ

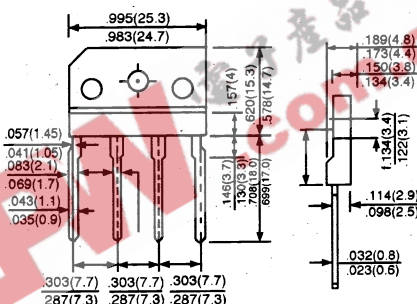

#### MAXIMUM RATINGS AND ELECTRICAL CHARACTERISTICS

Rating at 25°C ambient temperature unless otherwise specified.  
Single phase, half wave, 60 Hz, resistive or inductive load.  
For capacitive load, derate current by 20%

TYPE NUMBER	SYMBOLS	KBJ 601G	KBJ 602G	KBJ 604G	KBJ 606G	KBJ 608G	KBJ 610G	UNITS
Maximum Recurrent Peak Reverse Voltage	$V_{RRM}$	100	200	400	600	800	1000	V
Maximum RMS Voltage	$V_{RMS}$	70	140	280	420	560	700	V
Maximum D. C Blocking Voltage	$V_{DC}$	100	200	400	600	800	1000	V
Maximum average forward $T_C = 100^\circ\text{C}$ (NOTE 1) rectified output current $T_A = 40^\circ\text{C}$ (NOTE 2)	$I_{F(AV)}$	6 2.8						A
Peak forward surge current 8.3ms single half sine - wave superimposed on rated load (JEDED Method)	$I_{FSM}$	150						A
Maximum instantaneous forward drop per element at 6.0A	$V_F$	1.1						V
Maximum DC revers current at rated $T_A = 25^\circ\text{C}$ DC blocking Voltage per element $T_A = 100^\circ\text{C}$	$I_R$	5.0 500						$\mu\text{A}$
Typical junction capacitance (NOTE 3)	$C_J$	80						pF
Typical thermal resistance per leg (NOTE 1)	$R_{\theta JC}$	3.4						$^\circ\text{C/W}$
Operation Temperature and storage temperature range	$T_J, T_{STG}$	- 55 to + 150						$^\circ\text{C}$

- NOTES:**
1. Unite case mounted on 2.95 x 2.95 x 0.06" (75 x 75 x 1.6mm) Cu plate heatsink
  2. Unit mounted on P. C. B 0.5 x 0.5" (12 x 12mm) copper pads and 0.375" (9.5mm) lead length
  3. Measured at 1MHz and applied reverse Voltage of 4.0 Volts



## RATINGS AND CHARACTERISTIC CURVES

KBJ601G THRU KBJ610G

FIG. 1 - FORWARD OUTPUT CURRENT DERATING CURVE

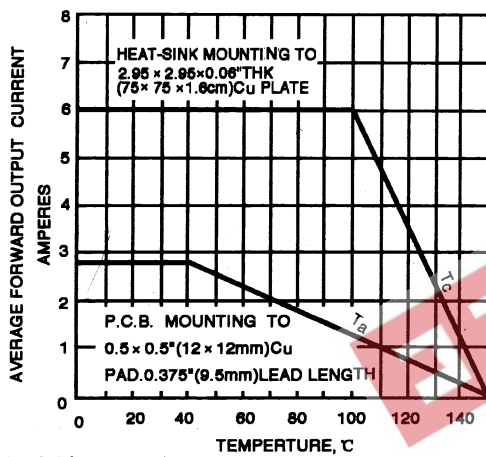

FIG. 2 - MAXIMUM NON-REPETITIVE FORWARD SURGE CURRENT - PER ELEMENT

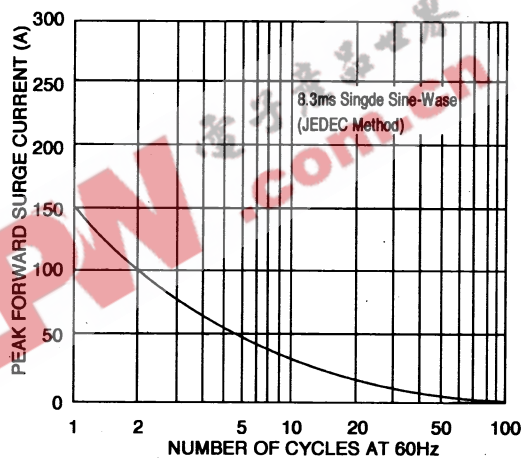

FIG. 3 - TYPICAL INSTANTANEOUS FORWARD CHARACTERISTICS - PER ELEMENT

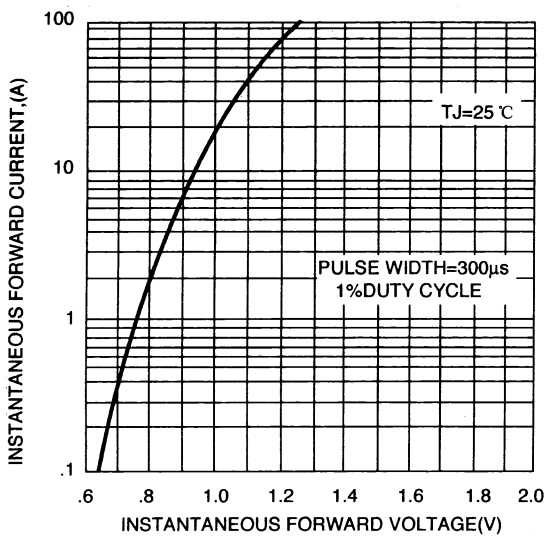

FIG. 4 - TYPICAL REVERSE CHARACTERISTICS - PER ELEMENT

