

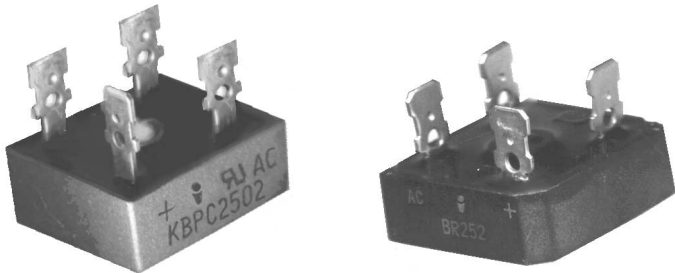

# KBPC2500 / BR250 SERIES

25 AMPERE SINGLE-PHASE SILICON BRIDGE RECTIFIER



## FEATURES

- High efficiency
- Surge overload rating - 300 amperes peak
- Body clad with metal (electrically isolated) or plastic
- Plastic encapsulation has Underwriters
- Laboratory flammability classification 94V-0
- Universal multipurpose terminals

## MECHANICAL DATA

- Case** : Metal or Plastic shell with plastic encapsulation
- Terminals**: 1/4inch, 6.35mm Faston blades \*
- Polarity** : Positive symbol printed on body
- Weight** : 1.1 ounce, 31.6 grams

## VOLTAGE RANGE

50 to 1000 Volts PRV

## CURRENT

25 Amperes

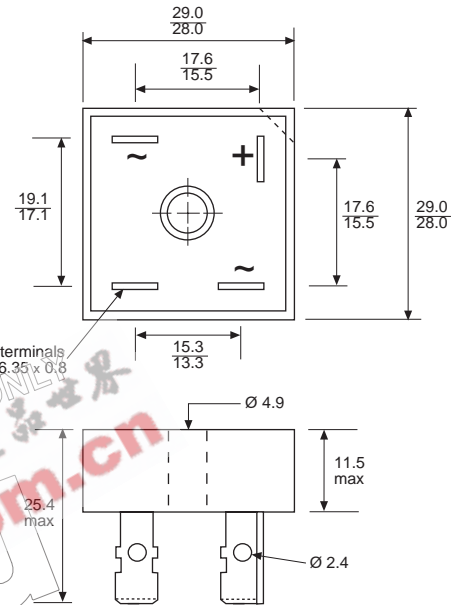

Dimensions in millimetres

## MAXIMUM RATINGS AND ELECTRICAL CHARACTERISTICS

Ratings at 25°C ambient temperature unless otherwise specified.  
Single phase, half wave, 60 Hz, resistive or inductive load. For capacitive load, derate current by 20%.

		Metal Case	KBPC25005	KBPC2501	KBPC2502	KBPC2504	KBPC2506	KBPC2508	KBPC2510	
		Plastic Case	BR2505	BR251	BR252	BR254	BR256	BR258	BR2510	
Maximum Recurrent Peak Reverse Voltage	VRRM		50	100	200	400	600	800	1000	V
Maximum Bridge Input Voltage RMS	VRMS		35	70	140	280	420	560	700	V
Maximum DC Blocking Voltage	VDC		50	100	200	400	600	800	1000	V
Maximum Average Forward Current at Tc = 55°C (see Fig 2)	IF(AV)		25.0							A
Peak Forward Surge Current, 8.3 ms single half sine - wave superimposed on rated load (see Fig 1)	IFSM		300							A
Maximum Forward Voltage Drop per Element at 12.5A (see Fig 3)	VF		1.2							V
Maximum Reverse Current at Rated DC Blocking Voltage per Element (see Fig 4) TA = 25°C TA = 100°C	IR		10.0 1.0							µA mA
RMS Isolation Voltage from Case to Terminals	VISO		2500							V
Operating Temperature Range	TJ		- 55 to + 125							°C
Storage Temperature Range	TSTG		- 55 to + 150							°C

\* Lead out wires can be supplied as an alternative to blades - add suffix W to part number e.g. KBPC2506W

# RATING AND CHARACTERISTIC CURVES KBPC2500/BR250 SERIES

**FIG 1 : MAXIMUM NON-REPETITIVE SURGE CURRENT PER ELEMENT**

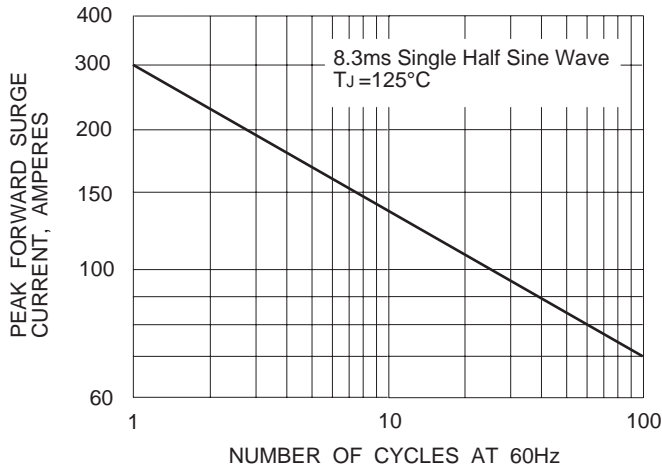

**FIG 2 : DERATING CURVE FOR RECTIFIED OUTPUT CURRENT**

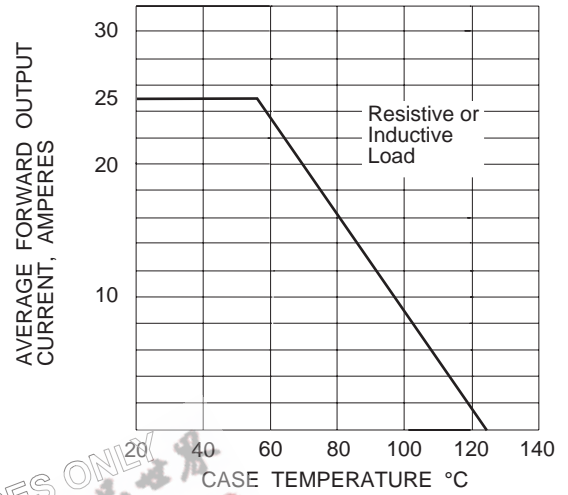

**FIG 3 : TYPICAL FORWARD CHARACTERISTICS PER ELEMENT**

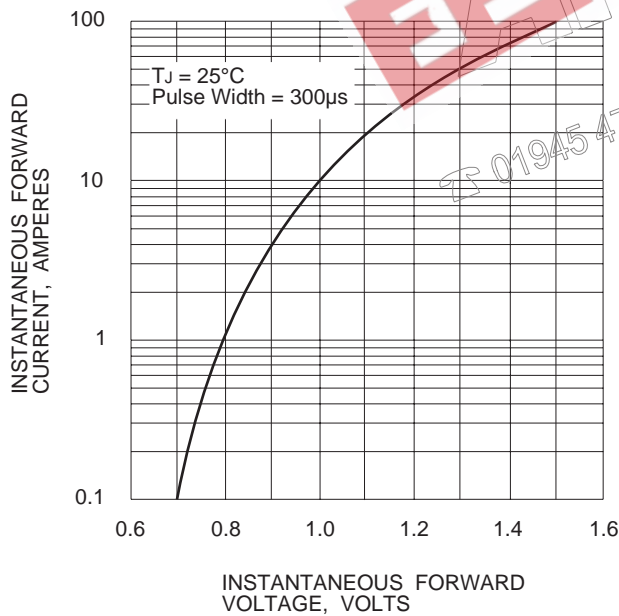

**FIG 4 : TYPICAL REVERSE CHARACTERISTICS PER ELEMENT**

