

### 2 INPUT AND GATE

#### FEATURES

- High Output Drive :  $\pm 24\text{mA}$  (Typ.)  
@ $V_{CC}=3\text{V}$
- Super High Speed Operation :  $t_{PD}=2.7\text{ns}$ (Typ.)  
@ $V_{CC}=5\text{V}$ , 50pF
- Operation Voltage Range :  $V_{CC(\text{opr})}=1.8\sim 5.5\text{V}$ .
- Supply Voltage Data Retention :  $V_{CC}=1.5\sim 5.5\text{V}$ .
- 5V Tolerant Function

#### MAXIMUM RATINGS

CHARACTERISTIC	SYMBOL	RATING	UNIT
Supply Voltage Range	$V_{CC}$	-0.5~6	V
DC Input Voltage	$V_{IN}$	-0.5~6	V
DC Output Voltage	$V_{OUT}$	-0.5~6	V
Input Diode Current	$I_{IK}$	$\pm 20$	mA
Output Diode Current	$I_{OK}$	$\pm 20$	mA
DC Output Current	$I_{OUT}$	$\pm 50$	mA
DC $V_{CC}$ /Ground Current	$I_{CC}$	$\pm 50$	mA
Power Dissipation	$P_D$	200	mW
Storage Temperature	$T_{stg}$	-65~150	$^{\circ}\text{C}$
Lead Temperature (10s)	$T_L$	260	$^{\circ}\text{C}$

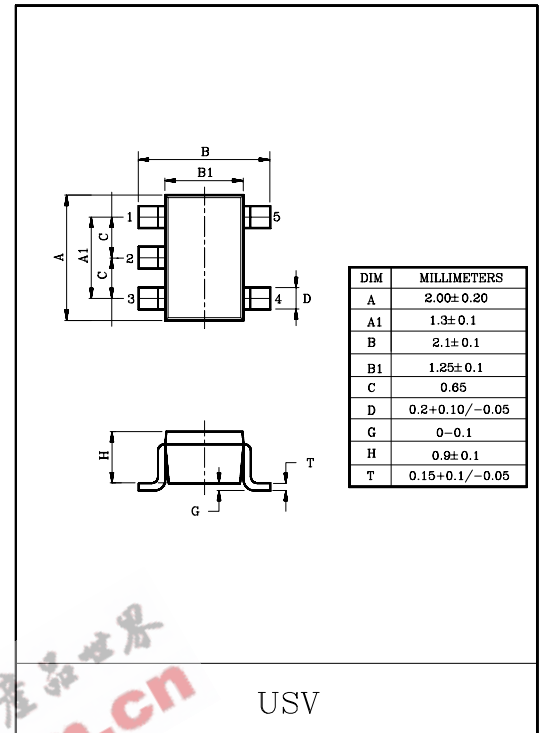

#### MARKING

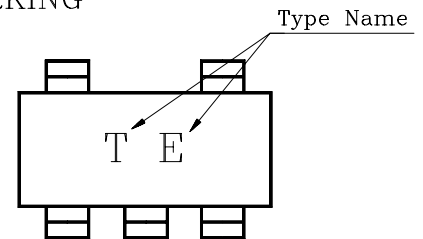

#### PIN CONNECTION(TOP VIEW)

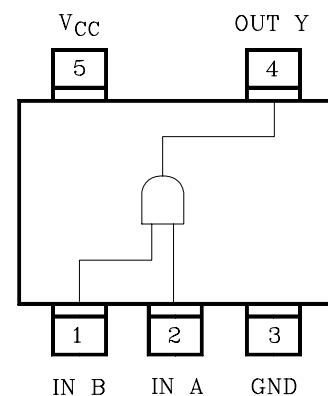

# KIC7SZ08FU

## LOGIC DIAGRAM

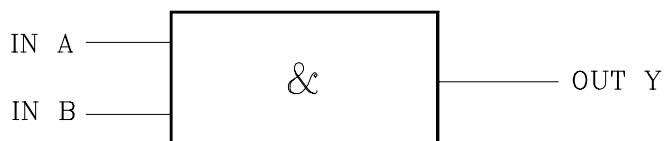

## DC ELECTRICAL CHARACTERISTICS

CHARACTERISTIC	SYMBOL	TEST CONDITION	V <sub>CC</sub> (V)	Ta=25°C			Ta=-40~85°C		UNIT			
				MIN.	TYP.	MAX.	MIN.	MAX.				
High-Level Input Voltage	V <sub>IH</sub>	-	1.8	0.88 ×V <sub>CC</sub>	-	-	0.88 ×V <sub>CC</sub>	-	V			
			2.3 ~ 5.5	0.75 ×V <sub>CC</sub>	-	-	0.75 ×V <sub>CC</sub>	-				
Low-Level Input Voltage	V <sub>IL</sub>	-	1.8	-	-	0.12 ×V <sub>CC</sub>	-	0.12 ×V <sub>CC</sub>	V			
			2.3 ~ 5.5	-	-	0.25 ×V <sub>CC</sub>	-	0.25 ×V <sub>CC</sub>				
High-Level Output Voltage	V <sub>OH</sub>	V <sub>IN</sub> =V <sub>IH</sub>	I <sub>OH</sub> =-100μA	1.8	1.7	1.8	-	1.7	-	V		
				2.3	2.2	2.3	-	2.2	-			
				3.0	2.9	3.0	-	2.9	-			
				4.5	4.4	4.5	-	4.4	-			
				I <sub>OH</sub> =-8mA	2.3	1.9	2.15	-	1.9		-	
					I <sub>OH</sub> =-16mA	3.0	2.4	2.8	-		2.4	-
						I <sub>OH</sub> =-24mA	3.0	2.3	2.68		-	2.3
I <sub>OH</sub> =-32mA	4.5	3.8	4.2		-		3.8	-				
	Low-Level Output Voltage	V <sub>OL</sub>	V <sub>IN</sub> =V <sub>IH</sub> or V <sub>IL</sub>	I <sub>OL</sub> =100μA	1.8	-	0	0.1	-	0.1	V	
2.3					-	0	0.1	-	0.1			
3.0					-	0	0.1	-	0.1			
4.5					-	0	0.1	-	0.1			
I <sub>OL</sub> =8mA				2.3	-	0.1	0.3	-	0.3			
				I <sub>OL</sub> =16mA	3.0	-	0.15	0.4	-	0.4		
					I <sub>OL</sub> =24mA	3.0	-	0.22	0.55	-		0.55
				I <sub>OL</sub> =32mA		4.5	-	0.22	0.55	-		0.55
Input Leakage Current	I <sub>IN</sub>	V <sub>IN</sub> =5.5V or GND	0 ~ 5.5		-	-	±1	-	±10	μA		
Power Off Leakage Current	I <sub>OFF</sub>	V <sub>IN</sub> or V <sub>OUT</sub> =5.5V	0.0	-	-	1	-	10				
Quiescent Supply Current	I <sub>CC</sub>	V <sub>IN</sub> =V <sub>CC</sub> or GND	5.5	-	-	2	-	20				

# KIC7SZ08FU

## AC ELECTRICAL CHARACTERISTICS (Input $t_r=t_f=3ns$ )

CHARACTERISTIC	SYMBOL	TEST CONDITION	Ta=25°C			Ta=-40~85°C		UNIT	
			V <sub>CC</sub> (V)	MIN.	TYP.	MAX.	MIN.		MAX.
Propagation Delay Time	t <sub>PLH</sub> t <sub>PHL</sub>	C <sub>L</sub> =15pF, R <sub>L</sub> =1MΩ	1.8	2.0	5.2	10.0	2.0	10.5	ns
			2.5±0.2	0.8	3.4	7.0	0.8	7.5	
			3.3±0.3	0.5	2.6	4.7	0.5	5.0	
			5.0±0.5	0.5	2.2	4.1	0.5	4.4	
		C <sub>L</sub> =50pF, R <sub>L</sub> =500Ω	3.3±0.3	1.5	3.3	5.2	1.5	5.5	
			5.0±0.5	0.8	2.7	4.5	0.8	4.8	
Input Capacitance	C <sub>IN</sub>	-	0~5.5	-	4	-	-	pF	
Power Dissipation Capacitance	C <sub>PD</sub>	(Note1)	3.3	-	20	-	-		
			5.5	-	25	-	-		

Note 1 : C<sub>PD</sub> defined as the value of internal equivalent capacitance of IC which is calculated from the operating current consumption without load (refer to Test Circuit.)

Average operating current can be obtained by the equation hereunder.

$$I_{CC(oper)} = C_{PD} \cdot V_{CC} \cdot f_{IN} + I_{CC}$$

EEPW.com.cn 电子产品世界