

Band pass filters for the receiving RF circuits of transceiver

- High stability and reliability with good performance and no adjustment.
- Wide and sharp pass band characteristics.
- Low insertion loss and deep stop band attenuation for interference.
- KF448S : SC-45 Package,
KF448V : SC-44 Package.
- F-11 Package Type : KF448.

MAXIMUM RATINGS (Ta=25°C)

ITEM	SYMBOL	RATING	UNIT
Input Signal Level	IS _{max}	0	dBm
DC Permissive Voltage	V _{DC}	+10	V
Operating Temperature Range	T _{opr}	-10~+50	°C
Storage Temperature Range	T _{stg}	-30~+85	°C

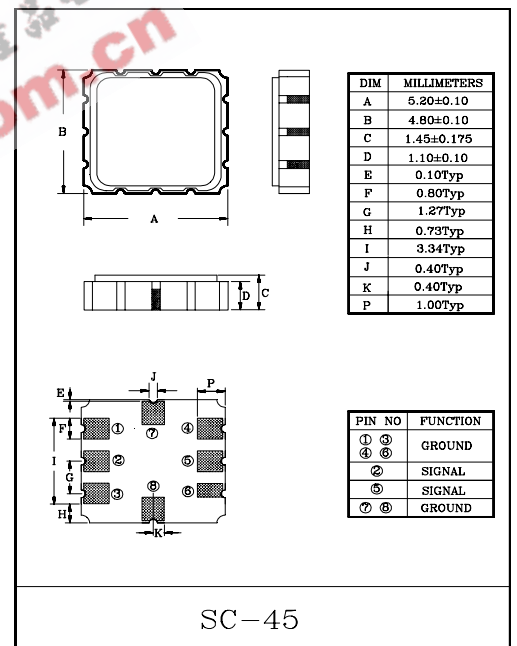
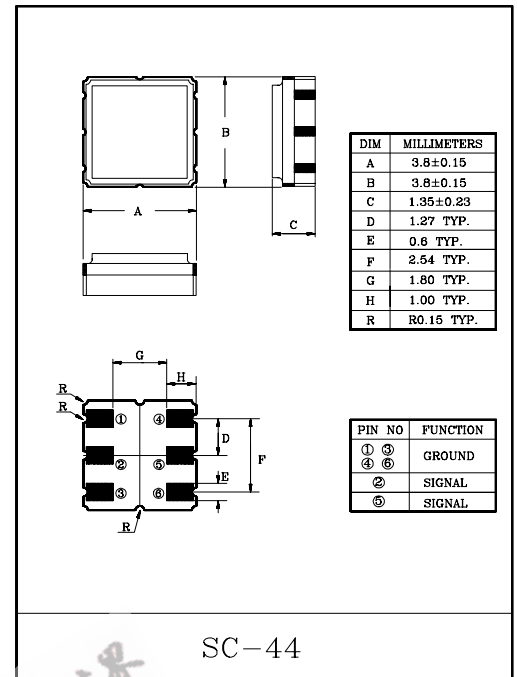

Marking

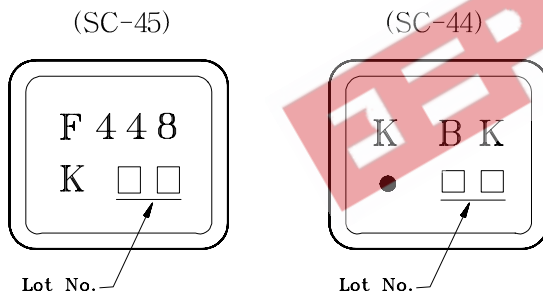

ELECTRICAL CHARACTERISTICS (Temperature 20±2°C, Humidity 65±5%)

ITEMS	SYMBOL	TEST CONDITION	MIN.	TYP.	MAX.	UNIT
Nominal Center Frequency	f ₀	-	-	448	-	MHz
Bandwidth	BW _{3dB}	-	f ₀ ±5	-	-	MHz
Insertion Loss	IL _{PASS}	f ₀ ±5MHz	-	-	4.0	dB
Ripple Level	A _{RIP}	f ₀ ±5MHz	-	-	2.0	dB
Rejection Level	IL _{STOP}	f ₀ -47.8~f ₀ -37.8MHz	55	-	-	dB
		f ₀ +37.8~f ₀ +47.8MHz	45	-	-	dB
Input/Output Impedance	Z _I (Z _O)	-	-	50Ω//0pF	-	-

TEST CIRCUIT

REFERENCE LEVEL TEST CIRCUIT

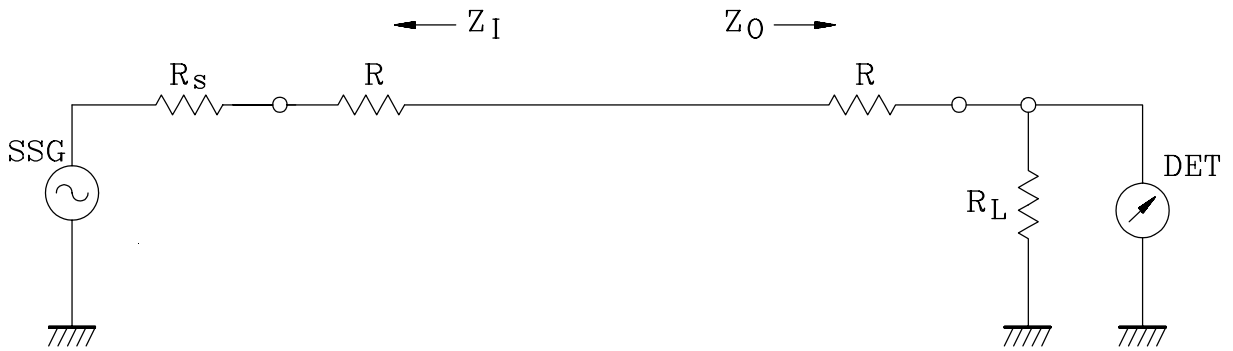

$R_s, R_L : 50\Omega$ (Internal Impedance of Source and Load)
 $R : 0\Omega$
 $Z_I(Z_O) = R_s(R_L) + R$

MEASUREMENT CIRCUIT

(SC-44)

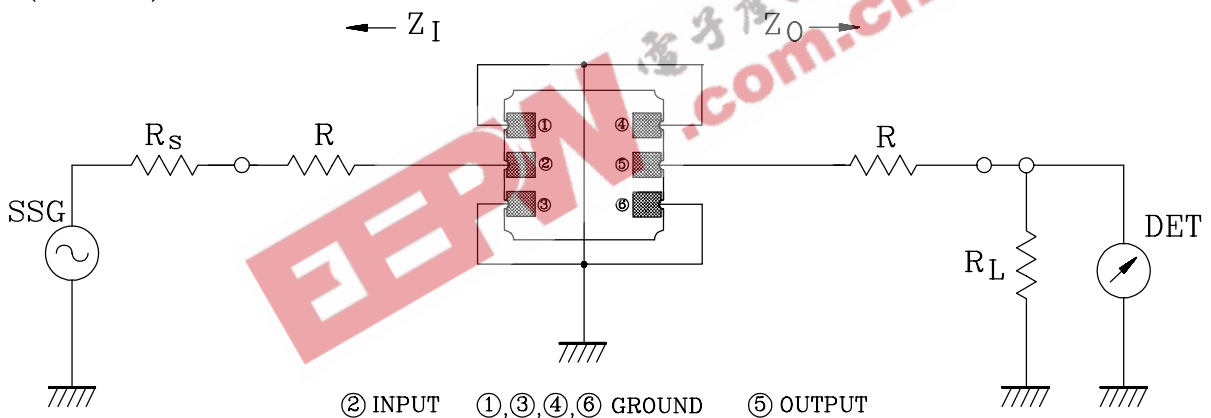

$R_s, R_L : 50\Omega$ (Internal Impedance of Source and Load)
 $R : 0\Omega$
 $Z_I(Z_O) = R_s(R_L) + R$

(SC-45)

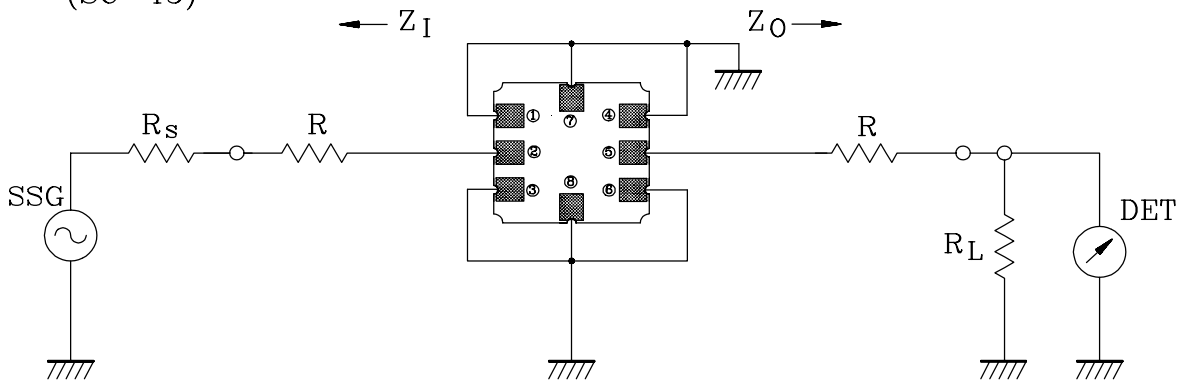

2: Input 1,3,4,6,7,8: Ground 5: Output

KF448S/V

