

OKI electronic components

KGF1262

Medium-Power Amplifier

GENERAL DESCRIPTION

The KGF1262 is a medium-power amplifier, with frequencies ranging from the UHF-band to the L-band, that features high gain, high output power, and low current operation. The KGF1262 specifications are guaranteed to a fixed matching circuit for 5.2 V and 1.9 GHz; external impedance-matching circuits are also required. Because of the high gain and high output power at the low operating current, the KGF1262 is ideal as a transmitter-driver amplifier for personal handy phones of more than 1.5 GHz band.

FEATURES

- High linear gain: 15 dB (min.) at 1.9 GHz
- High output power: 18 dBm (min.) at 1.9 GHz
- Low current operation: 70 mA (max.)
- Self-bias circuit configuration with built-in source capacitor
- package: 4PSOP

PACKAGE DIMENSIONS

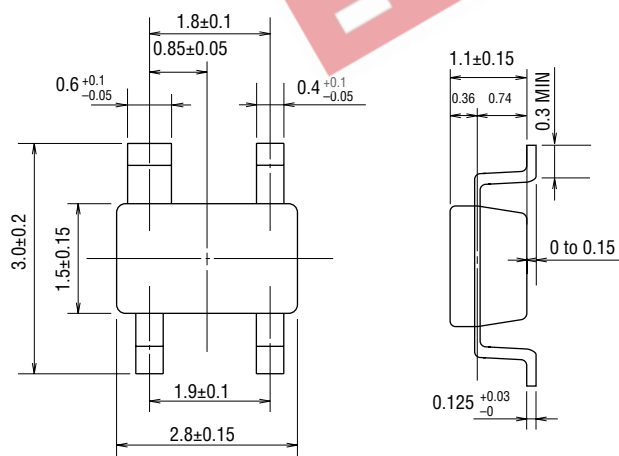

(Unit: mm)

| | |
|------------------------|----------------|
| Package material | Epoxy resin |
| Lead frame material | 42 alloy |
| Pin treatment | Solder plating |
| Solder plate thickness | 5 μm or more |

MARKING

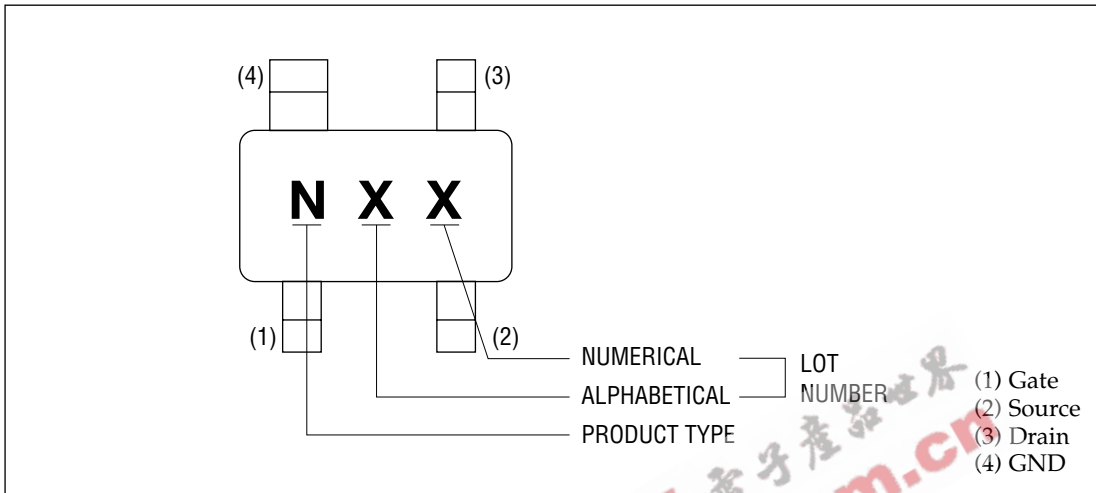

CIRCUIT

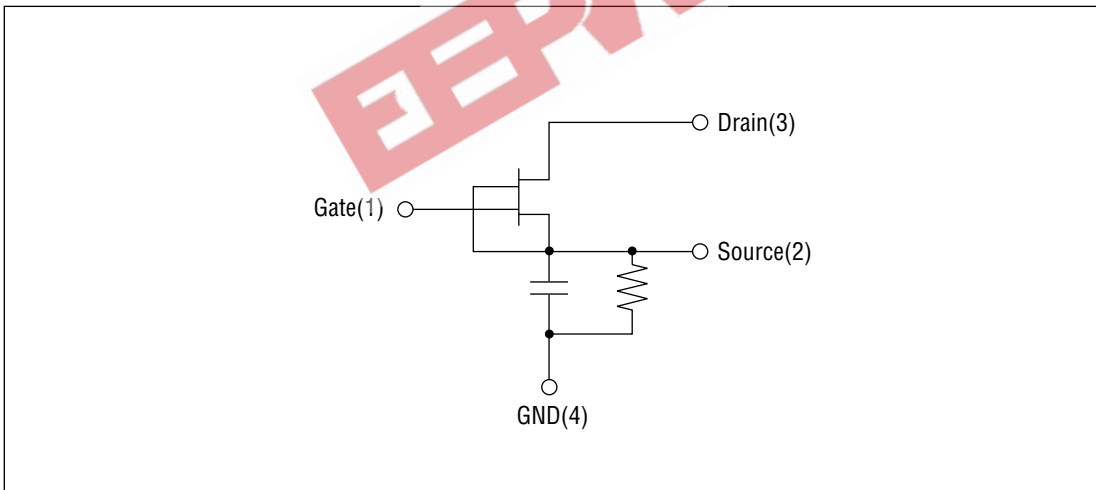

ABSOLUTE MAXIMUM RATINGS

| Item | Symbol | Condition | Unit | Min. | Max. |
|-------------------------|-----------|--------------------------|------------------|------|------|
| Drain-source voltage | V_{DS} | $T_a = 25^\circ\text{C}$ | V | — | 10 |
| Gate-source voltage | V_{GS} | $T_a = 25^\circ\text{C}$ | V | -5.0 | 0.4 |
| Drain current | I_{DS} | $T_a = 25^\circ\text{C}$ | mA | — | 360 |
| Total power dissipation | P_{tot} | $T_a = 25^\circ\text{C}$ | mW | — | 300 |
| Channel temperature | T_{ch} | — | $^\circ\text{C}$ | — | 150 |
| Storage temperature | T_{stg} | — | $^\circ\text{C}$ | -45 | 125 |

ELECTRICAL CHARACTERISTICS

(Ta = 25°C)

| Item | Symbol | Condition | Unit | Min. | Typ. | Max. |
|------------------------------|---------------|--|---------------|------|------|------|
| Gate-source leakage current | I_{GSS} | $V_{GS} = -5\text{ V}$ | mA | — | — | 0.1 |
| Gate-drain leakage current | I_{GDO} | $V_{GD} = -15\text{ V}$ | mA | — | — | 0.5 |
| Drain-source leakage current | $I_{DS(off)}$ | $V_{DS} = 3\text{ V}, V_{GS} = -2.5\text{ V}$ | mA | — | — | 1.0 |
| Drain current | I_{DSS} | $V_{DS} = 3\text{ V}, V_{GS} = 0\text{ V}$ | mA | 180 | — | — |
| Operating current | I_D | (*1), $P_{IN} = 7\text{ dBm}$ | mA | — | 50.0 | 70.0 |
| Gate-source cut-off voltage | $V_{GS(off)}$ | $V_{DS} = 3\text{ V}, I_{DS} = 720\text{ }\mu\text{A}$ | μA | -2.0 | — | -1.0 |
| Transconductance | g_m | $V_{DS} = 3\text{ V}, I_{DS} = 60\text{ mA}$ | mS | 100 | — | — |
| Linear gain | G_{LIN} | (*1), $P_{IN} = -10\text{ dBm}$ | dB | 15.0 | 16.5 | — |
| Output power | P_O | (*1), $P_{IN} = 7\text{ dBm}$ | dBm | 18.0 | 20.0 | — |

*1 Self-bias condition: $V_{DD} = 5\text{ V} \pm 0.25\text{ V}$, $V_G = 0\text{ V}$, $f = 1.9\text{ GHz}$

RF CHARACTERISTICS

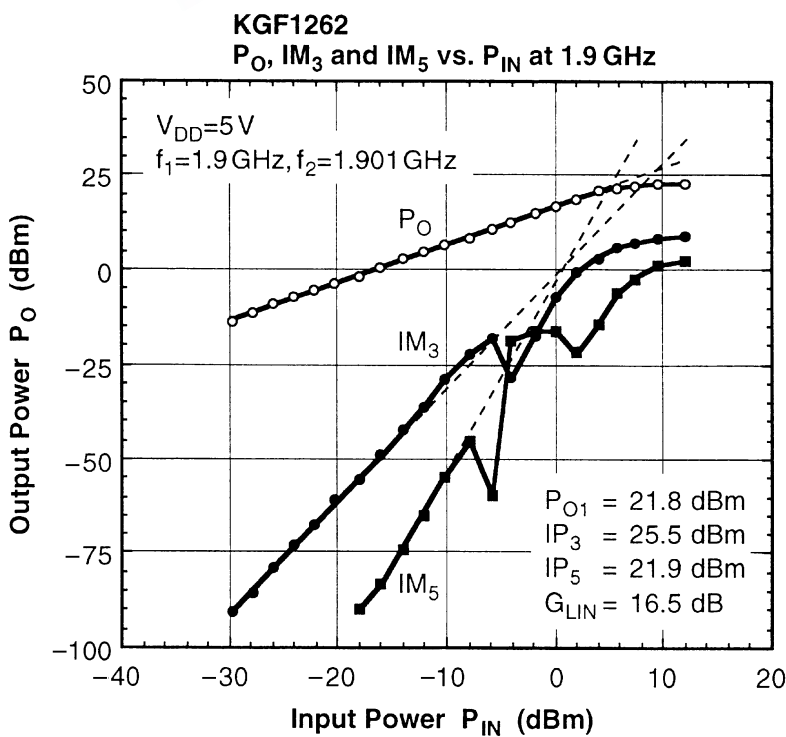
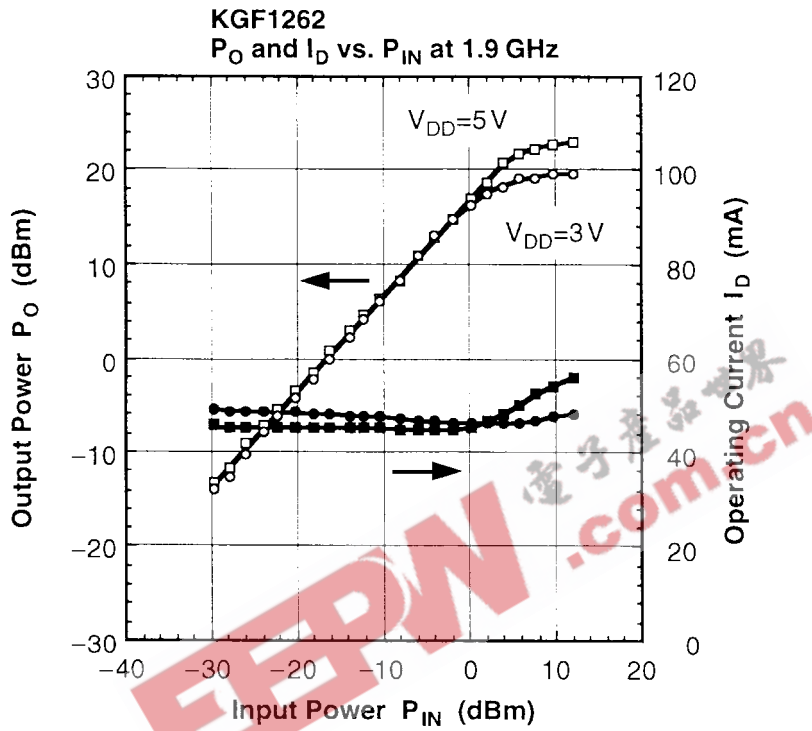

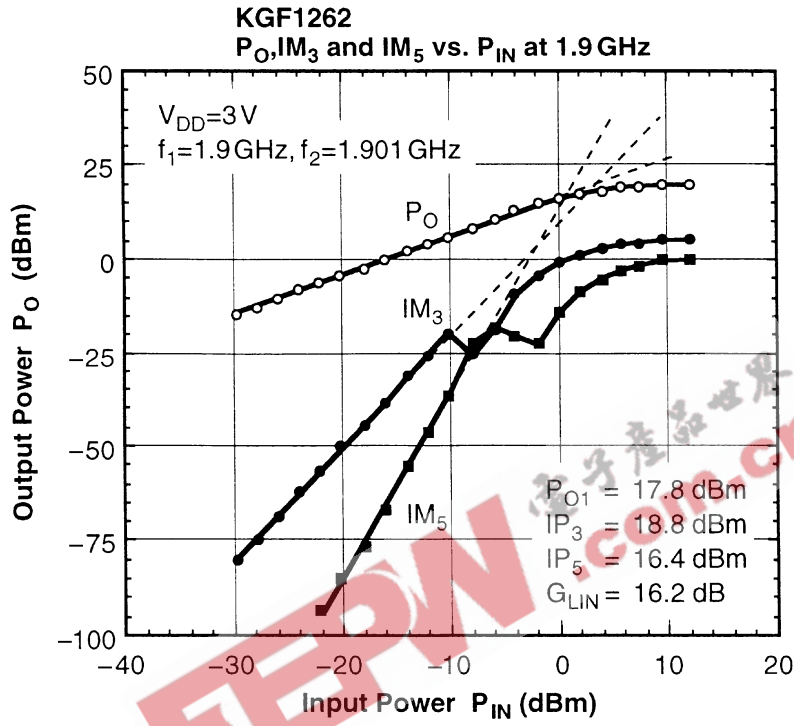

Typical S Parameters

 $V_{DD} = 5\text{ V}$, $V_G = 0\text{ V}$, $I_D = 45.4\text{ mA}$

| Freq(MHz) | MAG(S ₁₁) | ANG(S ₁₁) | MAG(S ₂₁) | ANG(S ₂₁) | MAG(S ₁₂) | ANG(S ₁₂) | MAG(S ₂₂) | ANG(S ₂₂) |
|-----------|-----------------------|-----------------------|-----------------------|-----------------------|-----------------------|-----------------------|-----------------------|-----------------------|
| 500.0 | 0.861 | -43.20 | 8.314 | 132.26 | 0.023 | 81.74 | 0.708 | -20.18 |
| 600.0 | 0.885 | -46.52 | 7.319 | 131.88 | 0.032 | 73.96 | 0.740 | -23.72 |
| 700.0 | 0.938 | -53.35 | 7.176 | 131.57 | 0.035 | 68.04 | 0.739 | -29.36 |
| 800.0 | 0.969 | -62.62 | 7.448 | 127.57 | 0.038 | 58.11 | 0.724 | -34.75 |
| 900.0 | 0.972 | -72.43 | 7.617 | 121.79 | 0.041 | 59.61 | 0.693 | -39.17 |
| 1000.0 | 0.942 | -82.27 | 7.566 | 113.36 | 0.037 | 52.91 | 0.657 | -42.84 |
| 1100.0 | 0.907 | -91.58 | 7.454 | 105.56 | 0.038 | 55.56 | 0.630 | -44.99 |
| 1200.0 | 0.852 | -99.25 | 7.080 | 97.79 | 0.037 | 61.75 | 0.610 | -46.73 |
| 1300.0 | 0.804 | -105.78 | 6.706 | 91.46 | 0.038 | 66.19 | 0.599 | -48.16 |
| 1400.0 | 0.756 | -112.04 | 6.346 | 85.32 | 0.038 | 75.05 | 0.591 | -49.34 |
| 1500.0 | 0.718 | -116.78 | 6.004 | 79.92 | 0.040 | 78.36 | 0.584 | -51.27 |
| 1600.0 | 0.681 | -121.54 | 5.672 | 74.96 | 0.046 | 85.13 | 0.589 | -52.35 |
| 1700.0 | 0.654 | -125.66 | 5.394 | 70.48 | 0.052 | 88.18 | 0.588 | -54.02 |
| 1800.0 | 0.631 | -129.73 | 5.093 | 65.90 | 0.057 | 93.35 | 0.594 | -56.54 |
| 1900.0 | 0.618 | -133.88 | 4.889 | 61.24 | 0.064 | 95.49 | 0.598 | -59.04 |
| 2000.0 | 0.603 | -137.40 | 4.659 | 57.66 | 0.074 | 95.70 | 0.605 | -60.99 |
| 2100.0 | 0.594 | -140.49 | 4.501 | 53.61 | 0.083 | 94.46 | 0.614 | -63.71 |
| 2200.0 | 0.585 | -143.89 | 4.321 | 50.05 | 0.095 | 94.21 | 0.619 | -66.74 |
| 2300.0 | 0.581 | -146.80 | 4.179 | 46.29 | 0.107 | 96.61 | 0.624 | -69.08 |
| 2400.0 | 0.582 | -150.18 | 4.056 | 42.23 | 0.117 | 94.20 | 0.628 | -72.55 |
| 2500.0 | 0.578 | -152.79 | 3.902 | 38.65 | 0.128 | 92.99 | 0.643 | -76.40 |
| 2600.0 | 0.581 | -156.41 | 3.786 | 35.05 | 0.143 | 91.07 | 0.646 | -80.05 |
| 2700.0 | 0.587 | -158.85 | 3.685 | 31.84 | 0.156 | 89.38 | 0.662 | -83.66 |
| 2800.0 | 0.592 | -161.90 | 3.578 | 27.91 | 0.171 | 88.38 | 0.668 | -86.20 |
| 2900.0 | 0.597 | -164.17 | 3.502 | 25.03 | 0.185 | 87.34 | 0.683 | -91.62 |
| 3000.0 | 0.611 | -167.83 | 3.398 | 20.74 | 0.202 | 84.36 | 0.696 | -96.08 |

Typical S Parameters

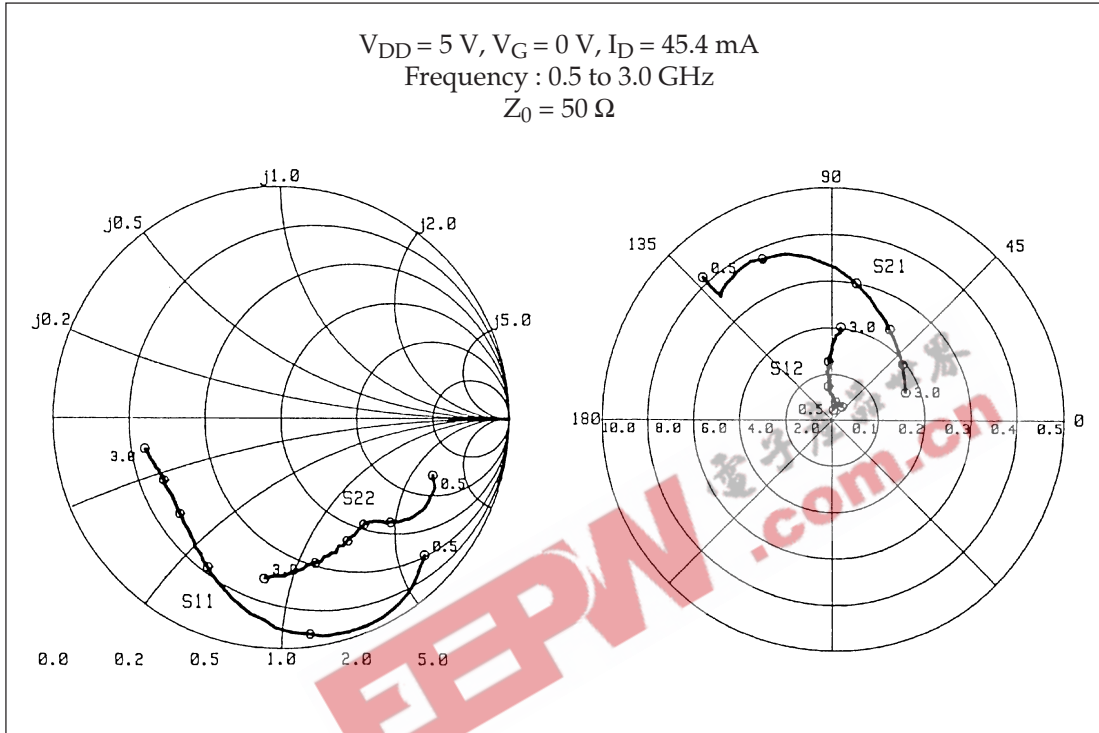

Typical S Parameters

 $V_{DD} = 3\text{ V}$, $V_G = 0\text{ V}$, $I_D = 48.5\text{ mA}$

| Freq(MHz) | MAG(S ₁₁) | ANG(S ₁₁) | MAG(S ₂₁) | ANG(S ₂₁) | MAG(S ₁₂) | ANG(S ₁₂) | MAG(S ₂₂) | ANG(S ₂₂) |
|-----------|-----------------------|-----------------------|-----------------------|-----------------------|-----------------------|-----------------------|-----------------------|-----------------------|
| 500.0 | 0.916 | -43.51 | 6.335 | 140.34 | 0.027 | 98.55 | 0.457 | -4.57 |
| 600.0 | 0.927 | -48.23 | 5.762 | 139.83 | 0.039 | 83.96 | 0.498 | -8.99 |
| 700.0 | 0.964 | -54.71 | 5.580 | 136.14 | 0.042 | 75.40 | 0.502 | -19.93 |
| 800.0 | 0.993 | -63.63 | 5.892 | 132.31 | 0.043 | 69.15 | 0.515 | -24.18 |
| 900.0 | 1.005 | -72.69 | 5.909 | 126.70 | 0.048 | 69.44 | 0.483 | -28.86 |
| 1000.0 | 0.987 | -82.39 | 6.026 | 117.94 | 0.047 | 65.48 | 0.493 | -33.12 |
| 1100.0 | 0.967 | -91.73 | 5.982 | 111.07 | 0.051 | 67.55 | 0.477 | -34.38 |
| 1200.0 | 0.920 | -99.80 | 5.754 | 101.93 | 0.053 | 67.95 | 0.490 | -39.74 |
| 1300.0 | 0.876 | -107.04 | 5.571 | 95.56 | 0.055 | 70.09 | 0.495 | -41.60 |
| 1400.0 | 0.836 | -113.69 | 5.299 | 88.68 | 0.059 | 72.60 | 0.498 | -45.70 |
| 1500.0 | 0.797 | -119.30 | 5.086 | 82.78 | 0.060 | 73.94 | 0.501 | -49.18 |
| 1600.0 | 0.763 | -124.95 | 4.821 | 77.21 | 0.065 | 76.41 | 0.507 | -52.17 |
| 1700.0 | 0.733 | -129.64 | 4.628 | 71.96 | 0.071 | 78.66 | 0.514 | -55.11 |
| 1800.0 | 0.706 | -134.46 | 4.421 | 67.14 | 0.076 | 80.42 | 0.524 | -58.04 |
| 1900.0 | 0.691 | -139.12 | 4.262 | 61.28 | 0.083 | 84.73 | 0.540 | -62.81 |
| 2000.0 | 0.669 | -143.06 | 4.068 | 56.47 | 0.089 | 83.56 | 0.562 | -66.89 |
| 2100.0 | 0.661 | -146.80 | 3.913 | 51.74 | 0.100 | 83.44 | 0.562 | -71.44 |
| 2200.0 | 0.651 | -149.92 | 3.747 | 47.17 | 0.112 | 83.94 | 0.576 | -76.90 |
| 2300.0 | 0.643 | -153.50 | 3.620 | 43.20 | 0.123 | 86.10 | 0.578 | -79.82 |
| 2400.0 | 0.648 | -157.16 | 3.475 | 38.19 | 0.136 | 84.08 | 0.579 | -85.80 |
| 2500.0 | 0.638 | -160.05 | 3.359 | 34.18 | 0.146 | 84.76 | 0.598 | -90.54 |
| 2600.0 | 0.646 | -164.22 | 3.210 | 30.03 | 0.164 | 81.24 | 0.591 | -96.30 |
| 2700.0 | 0.650 | -167.02 | 3.130 | 26.08 | 0.176 | 80.05 | 0.618 | -101.05 |
| 2800.0 | 0.651 | -170.84 | 3.000 | 21.96 | 0.193 | 78.05 | 0.607 | -104.47 |
| 2900.0 | 0.659 | -173.51 | 2.930 | 18.10 | 0.211 | 76.90 | 0.634 | -112.05 |
| 3000.0 | 0.667 | -177.55 | 2.809 | 13.75 | 0.225 | 74.08 | 0.638 | -117.04 |

Typical S Parameters

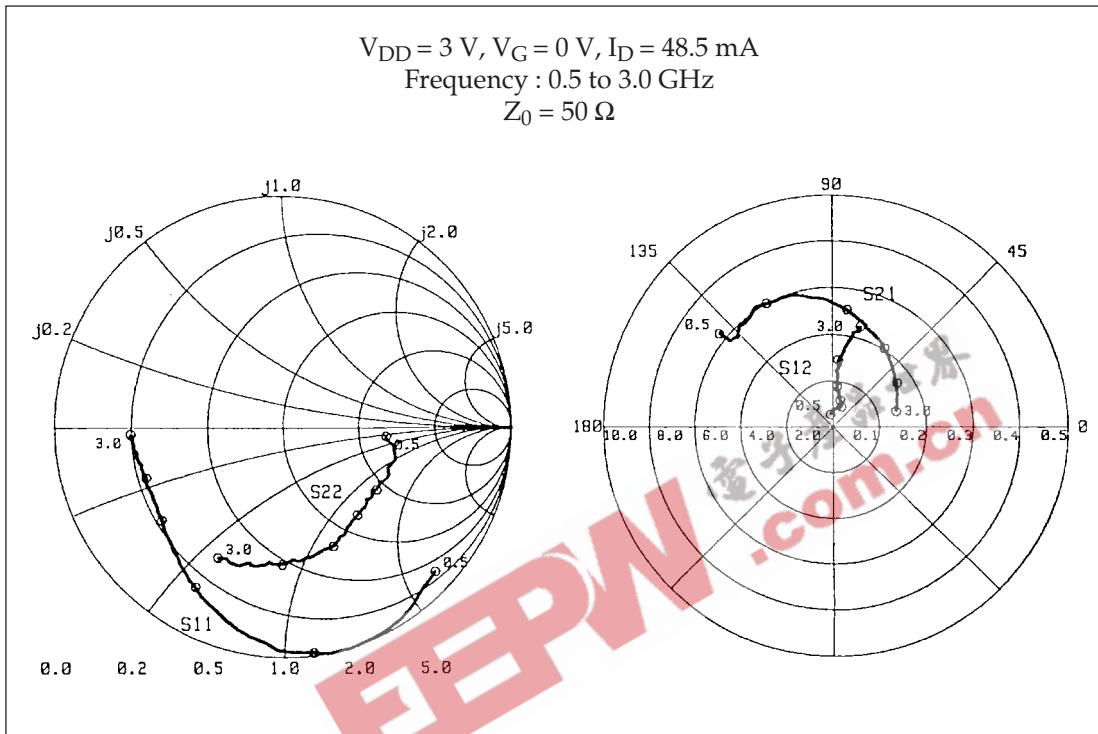

Test Circuit and Bias Configuration for KGF1262 at 1.9 GHz

