



LC75343M

Electronic Volume Control System on-Chip



Overview

The LC75343M is an electronic volume system that can control the volume, balance, 2-band equalizer, super bass, and input switching functions by serial data input.

Functions

- Volume: 0 dB to -78 dB (1-dB step) and $-\infty$ (64 positions)
0 dB to -50 dB (1-dB step), -50 dB to -70 dB (2-dB step), -70 dB to -78 dB (4-dB step)
Balance function with separate L/R control
- Treble: ± 10 -dB control in 2-dB steps is possible. Shelving characteristic.
- Bass*: ± 10 -dB control in 2-dB steps is possible. Peaking characteristics.
- Super bass*: +10-dB control in 2-dB steps is possible. Peaking characteristics.
(+/-10 dB control in 2-dB steps is possible depending on software support and the application. Peaking characteristics.)
- Selector: 5 input signals can be selected both for L and R
- Input gain: 0 dB to +30 dB (2-dB step) amplification is possible for the input signal.
- General-purpose amp (ATT): 2 on-chip general-purpose amplifiers
(0-dB to -18-dB in 2-dB steps and $-\infty$ 11 positions attenuate control is possible, depending on software support and the application)

Note*: Regarding (Bass) and (Super bass) above, MID and BASS functions can also be realized by changing the capacitor capacitance.

Features

- On-chip buffer amplifier cuts down number of external components
- Low switching noise generated by on-chip switch due to use of silicon gate CMOS process
- On-chip reference voltage circuit for analog ground
- Controls performed with serial data input (CCB)

Package Dimensions

unit: mm

3263-MFP36SDJ (375 mil)

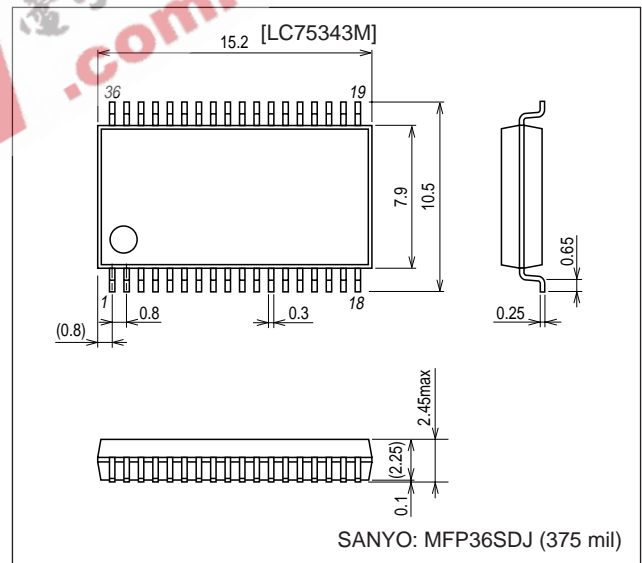

- CCB is a trademark of SANYO ELECTRIC CO., LTD.
- CCB is SANYO's original bus format and all the bus addresses are controlled by SANYO.

■ Any and all SANYO products described or contained herein do not have specifications that can handle applications that require extremely high levels of reliability, such as life-support systems, aircraft's control systems, or other applications whose failure can be reasonably expected to result in serious physical and/or material damage. Consult with your SANYO representative nearest you before using any SANYO products described or contained herein in such applications.

■ SANYO assumes no responsibility for equipment failures that result from using products at values that exceed, even momentarily, rated values (such as maximum ratings, operating condition ranges, or other parameters) listed in products specifications of any and all SANYO products described or contained herein.

SANYO Electric Co., Ltd. Semiconductor Company

TOKYO OFFICE Tokyo Bldg., 1-10, 1 Chome, Ueno, Taito-ku, TOKYO, 110-8534 JAPAN

LC75343M

Pin Assignment

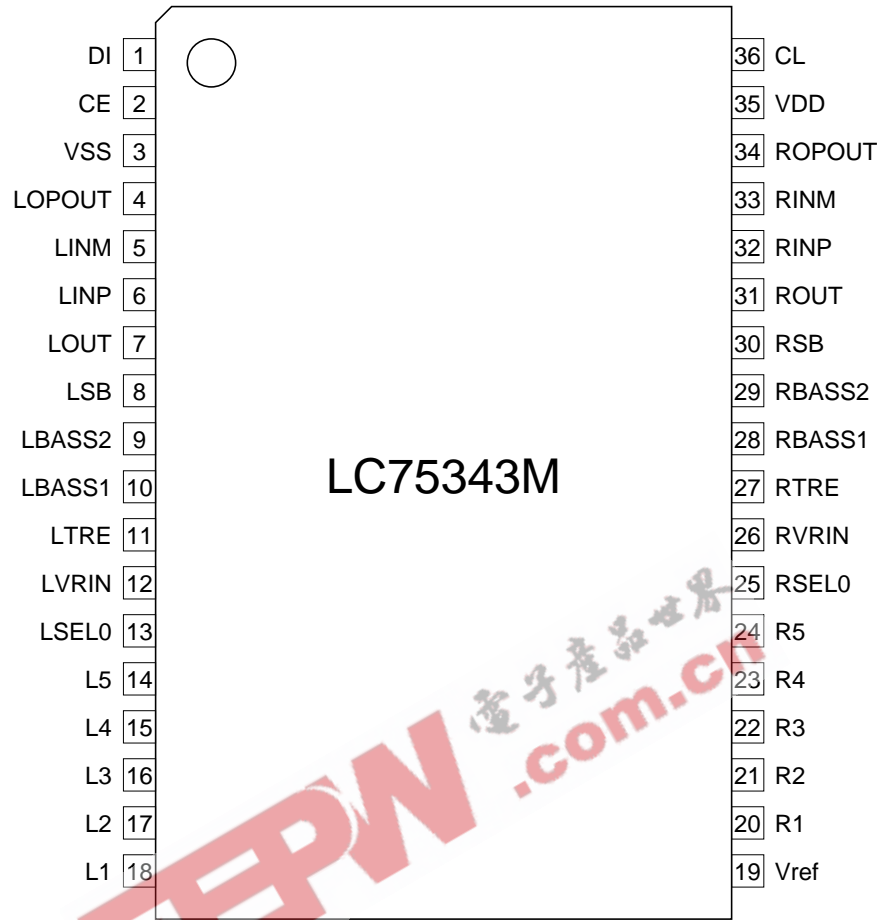

Sample Application Circuit

- General-Purpose Op-Amp Specifications)

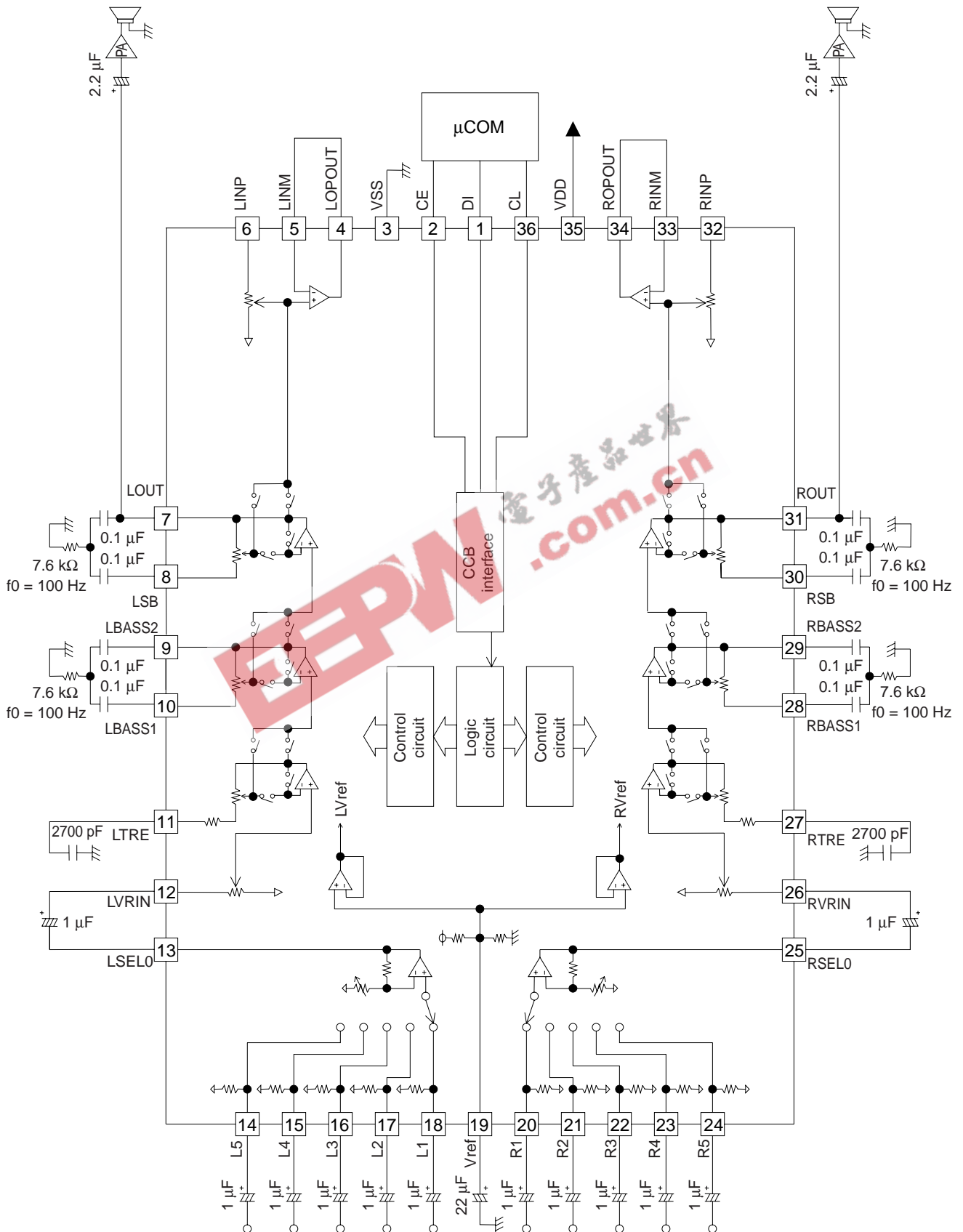

• ATT Control Specifications

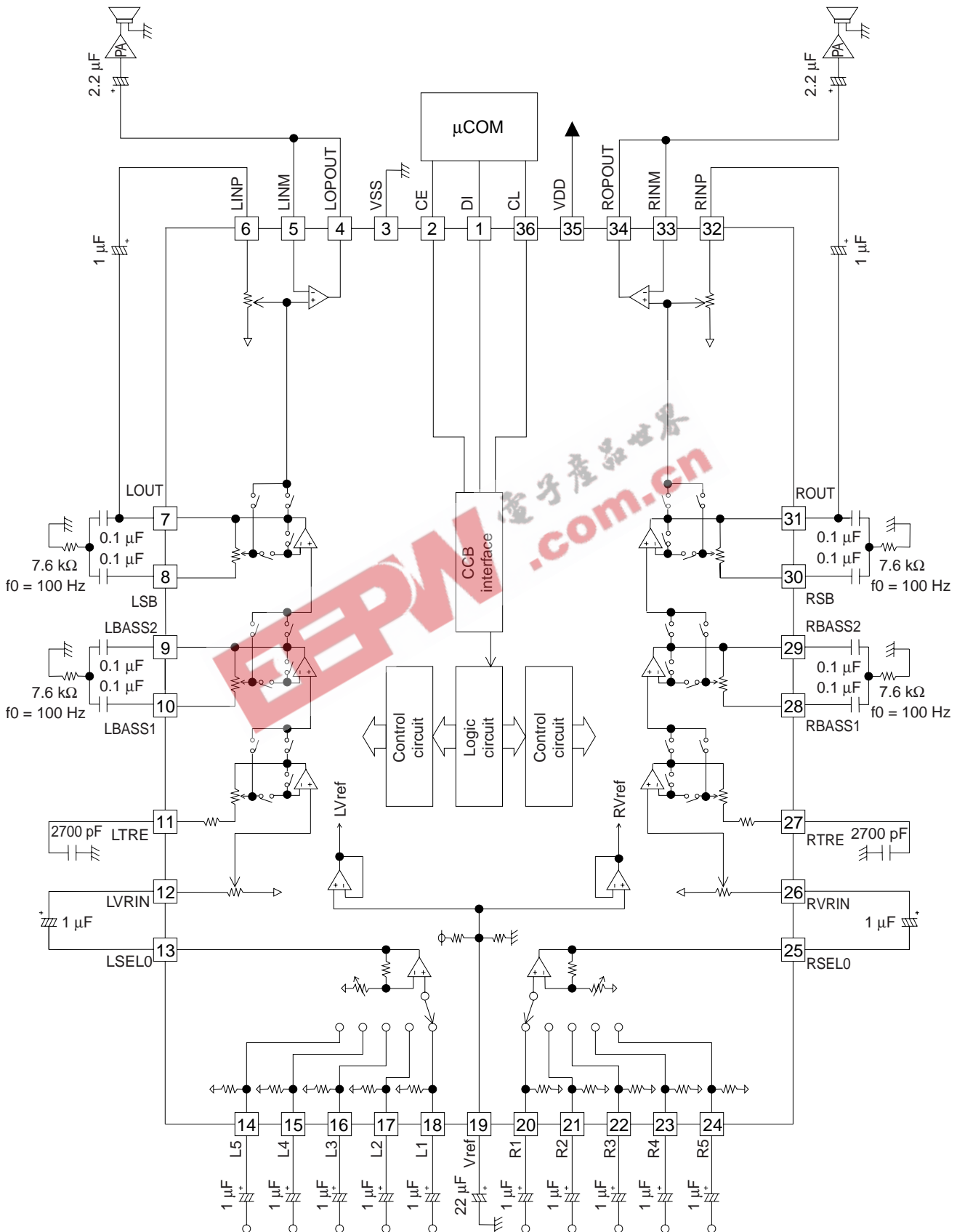

LC75343M

• 3-Band Specifications

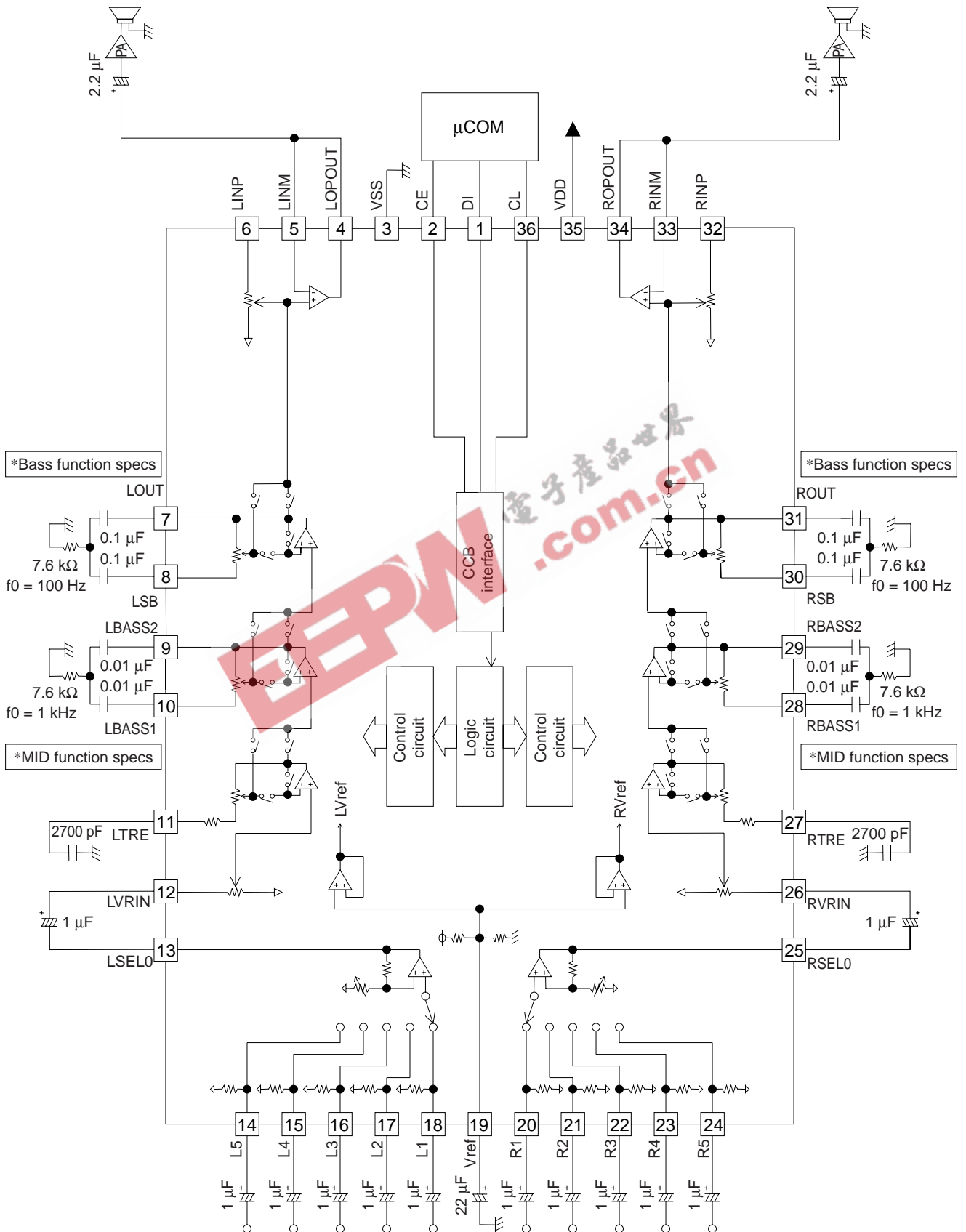

Specifications

Absolute Maximum Ratings at $T_a = 25^\circ\text{C}$, $V_{SS} = 0\text{ V}$

Parameter	Symbol	Pin Name	Conditions	Ratings	Unit
Maximum supply voltage	$V_{DD\text{ max}}$	V_{DD}		10.5	V
Maximum input voltage	$V_{IN\text{ max}}$	CE, DI, CL		-0.3 to +10.5	V
		L1 to L5, R1 to R5, LVRIN, RVRIN, LINP, RINP, LINM, RINM		$V_{SS} - 0.3$ to $V_{DD} + 0.3$	
Allowable power dissipation	$P_{d\text{ max}}$		$T_a \leq 75^\circ\text{C}$, independent IC	520	mW
Operating temperature	T_{op}			-30 to +75	$^\circ\text{C}$
Storage temperature	T_{stg}			-40 to +125	$^\circ\text{C}$

Allowable Operating Ranges at $T_a = -30$ to $+75^\circ\text{C}$, $V_{SS} = 0\text{ V}$

Parameter	Symbol	Pin Name	Conditions	Ratings			Unit
				min	typ	max	
Supply voltage	V_{DD}	V_{DD}		4.5		9	V
Input high-level voltage	V_{IH}	CL, DI, CE		2.0		9	V
Input low-level voltage	V_{IL}	CL, DI, CE	$7.5 \leq V_{DD} \leq 9$	V_{SS}		0.8	V
			$4.5 \leq V_{DD} \leq 7.5$	V_{SS}		0.3	
Input amplitude voltage	V_{IN}	L1 to L5, R1 to R5, LVRIN, RVRIN, LINP, RINP, LINM, RINM		V_{SS}		V_{DD}	Vp-p
Input pulse width	$t_{\theta W}$	CL		1			μs
Setup time	t_{setup}	CL, DI, CE		1			μs
Hold time	t_{hold}	CL, DI, CE		1			μs
Operating frequency	f_{opg}	CL				500	kHz

Electrical Characteristics at $T_a = 25^\circ\text{C}$, $V_{DD} = 8\text{ V}$, $V_{SS} = 0\text{ V}$

Input block

Parameter	Symbol	Pin Name	Conditions	Ratings			Unit
				min	typ	max	
Maximum input gain	$G_{in\text{ max}}$				+30		dB
Step resolution	G_{step}				+2		dB
Input resistance	R_{in}	L1, L2, L3, L4, L5 R1, R2, R3, R4, R5			50		$\text{k}\Omega$
Clipping level	V_{cl}	LSEL0, RSEL0	THD = 1.0%, $f = 1\text{ kHz}$		2.50		Vrms
Output load resistance	R_l	LSEL0, RSEL0		10			$\text{k}\Omega$

Volume block

Parameter	Symbol	Pin Name	Conditions	Ratings			Unit
				min	typ	max	
Input resistance	R_{in}	LVRIN, RVRIN			50		$\text{k}\Omega$

Treble band equalizer control block

Parameter	Symbol	Pin Name	Conditions	Ratings			Unit
				min	typ	max	
Control range	G_{eq}		max. boost/cut	± 8	± 10	± 12	dB
Step resolution	E_{step}			1	2	3	dB
Internal feedback resistance	R_{feed}				51.7		$\text{k}\Omega$

LC75343M

Bass (mid) band equalizer control block

Parameter	Symbol	Pin Name	Conditions	Ratings			Unit
				min	typ	max	
Control range	Geq		max. boost/cut	±8	±10	±12	dB
Step resolution	Estep			1	2	3	dB
Internal feedback resistance	Rfeed				33.1		kΩ

Super bass (bass) band equalizer control block

Parameter	Symbol	Pin Name	Conditions	Ratings			Unit
				min	typ	max	
Control range (super bass specs)	Geq		max. boost	+8	+10	+12	dB
Control range (3-band specs)			max. boost/cut	±8	±10	±12	dB
Step resolution	Estep			1	2	3	dB
Internal feedback resistance	Rfeed				33.1		kΩ

General-purpose/ATT op-amp block

Parameter	Symbol	Pin Name	Conditions	Ratings			Unit
				min	typ	max	
Input resistance	Rin	LINP, RINP			50		kΩ

General

Parameter	Symbol	Conditions	Ratings			Unit
			min	typ	max	
Total harmonic distortion (General-purpose op-amp specs)	THD	$V_{IN} = 1 V_{rms}$, $f = 1$ KHz, total flat overall		0.006	0.01	%
Total harmonic distortion (ATT, 3-band specs)				0.007	0.01	%
Crosstalk (General-purpose op-amp specs)	CT	$V_{IN} = 1 V_{rms}$, $f = 1$ KHz, $R_g = 1$ kΩ, total flat overall	80			dB
Crosstalk (ATT, 3-band specs)			80			dB
Output noise voltage (General-purpose op-amp specs)	VN	Flat overall, 80 kHz L.P.F		9.3		μV
Output noise voltage (ATT, 3-band specs)				10.4		μV
Maximum attenuated output (General-purpose op-amp specs)	Vomin	Flat overall, $f = 1$ kHz		-90		dB
Maximum attenuated characteristics (ATT, 3-band specs)				-90		dB
Curent drain	I_{DD}	$V_{DD} - V_{SS} = +9$ V		40		mA
Input high-level current	I_{IH}	CL, DI, CE: $V_{IN} = 9$ V			10	μA
Input low-level current	I_{IL}	CL, DI, CE: $V_{IN} = 0$ V	-10			μA

Control Timing and Data Format

To control the LC75343M, input specified serial data to the CL, DI, and CE pins. The data configuration consists of a total of 40 bits broken down into 8 address bits and 32 data bits.

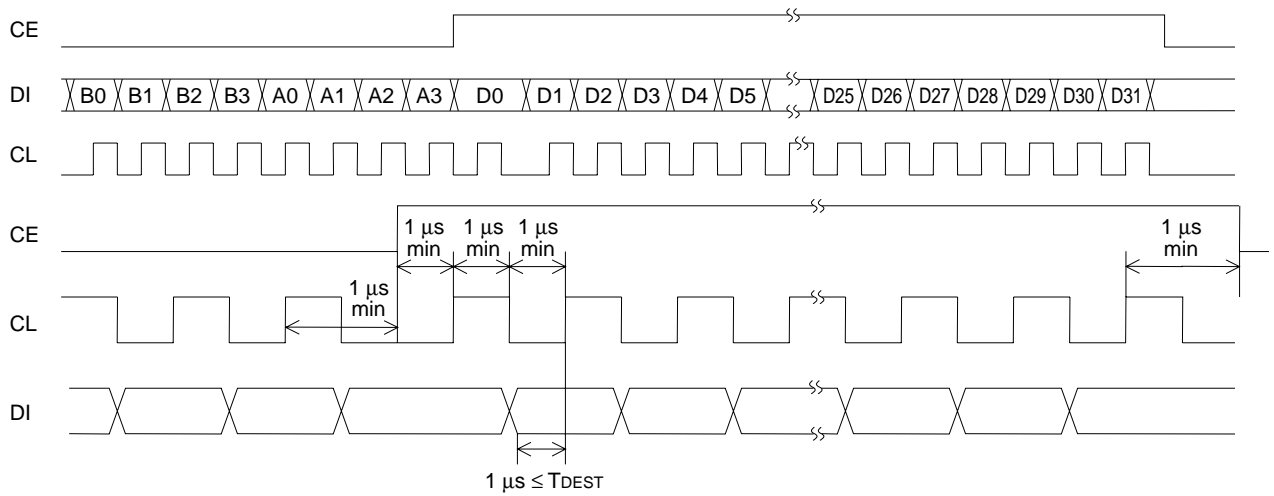

Address Code (B0 to A3)

The LC75343M has an 8-bit address code and common specifications with a SANYO serial bus CCB IC are possible.

Address code	B0	B1	B2	B3	A0	A1	A2	A3	
(LSB)	0	1	0	0	0	0	0	1	(82HEX)

Control Code Allocation

General-purpose op-amp, ATT control specifications (D3 = 0)

Input switching control

(L1, L2, L3, L4, L5, R1, R2, R3, R4, R5)

D0	D1	D2	D3	Operation
0	0	0	0	L1 (R1) on
1	0	0	0	L2 (R2) on
0	1	0	0	L3 (R3) on
1	1	0	0	L4 (R4) on
0	0	1	0	L5 (R5) on
1	0	1	0	Analog ground connection
0	1	1	0	Test mode
1	1	1	0	Must not be used in normal operation.

3-band specifications (D3 = 1)

Input switching control

(L1, L2, L3, L4, L5, R1, R2, R3, R4, R5)

D0	D1	D2	D3	Operation
0	0	0	0	L1 (R1) on
1	0	0	0	L2 (R2) on
0	1	0	0	L3 (R3) on
1	1	0	0	L4 (R4) on
0	0	1	0	L5 (R5) on
1	0	1	0	Analog ground connection
0	1	1	0	Test mode
1	1	1	0	Must not be used in normal operation.

Input gain control

D4	D5	D6	D7	Operation
0	0	0	0	0 dB
1	0	0	0	+2 dB
0	1	0	0	+4 dB
1	1	0	0	+6 dB
0	0	1	0	+8 dB
1	0	1	0	+10 dB
0	1	1	0	+12 dB
1	1	1	0	+14 dB
0	0	0	1	+16 dB
1	0	0	1	+18 dB
0	1	0	1	+20 dB
1	1	0	1	+22 dB
0	0	1	1	+24 dB
1	0	1	1	+26 dB
0	1	1	1	+28 dB
1	1	1	1	+30 dB

LC75343M

Volume control

D8	D9	D10	D11	D12	D13	Operation
0	0	0	0	0	0	0 dB
1	0	0	0	0	0	-1 dB
0	1	0	0	0	0	-2 dB
1	1	0	0	0	1	-3 dB
0	0	1	0	0	0	-4 dB
1	0	1	0	0	0	-5 dB
0	1	1	0	0	0	-6 dB
1	1	1	0	0	0	-7 dB
0	0	0	1	0	0	-8 dB
1	0	0	1	0	0	-9 dB
0	1	0	1	0	0	-10 dB
1	1	0	1	0	0	-11 dB
0	0	1	1	0	0	-12 dB
1	0	1	1	0	0	-13 dB
0	1	1	1	0	0	-14 dB
1	1	1	1	0	0	-15 dB
0	0	0	0	1	0	-16 dB
1	0	0	0	1	0	-17 dB
0	1	0	0	1	0	-18 dB
1	1	0	0	1	0	-19 dB
0	0	1	0	1	0	-20 dB
1	0	1	0	1	0	-21 dB
0	1	1	0	1	0	-22 dB
1	1	1	0	1	0	-23 dB
0	0	0	1	1	0	-24 dB
1	0	0	1	1	0	-25 dB
0	1	0	1	1	0	-26 dB
1	1	0	1	1	0	-27 dB
0	0	1	1	1	0	-28 dB
1	0	1	1	1	0	-29 dB
0	1	1	1	1	0	-30 dB
1	1	1	1	1	0	-31 dB
0	0	0	0	0	1	-32 dB
1	0	0	0	0	1	-33 dB
0	1	0	0	0	1	-34 dB
1	1	0	0	0	1	-35 dB
0	0	1	0	0	1	-36 dB
1	0	1	0	0	1	-37 dB
0	1	1	0	0	1	-38 dB
1	1	1	0	0	1	-39 dB
0	0	0	1	0	1	-40 dB
1	0	0	1	0	1	-41 dB
0	1	0	1	0	1	-42 dB
1	1	0	1	0	1	-43 dB
0	0	1	1	0	1	-44 dB
1	0	1	1	0	1	-45 dB
0	1	1	1	0	1	-46 dB
1	1	1	1	0	1	-47 dB
0	0	0	0	1	1	-48 dB
1	0	0	0	1	1	-49 dB
0	1	0	0	1	1	-50 dB

Continued on next page.

Continued from preceding page.

D8	D9	D10	D11	D12	D13	Operation
1	1	0	0	1	1	-52 dB
0	0	1	0	1	1	-54 dB
1	0	1	0	1	1	-56 dB
0	1	1	0	1	1	-58 dB
1	1	1	0	1	1	-60 dB
0	0	0	1	1	1	-62 dB
1	0	0	1	1	1	-64 dB
0	1	0	1	1	1	-66 dB
1	1	0	1	1	1	-68 dB
0	0	1	1	1	1	-70 dB
1	0	1	1	1	1	-74 dB
0	1	1	1	1	1	-78 dB
1	1	1	1	1	1	-∞ dB

Channel selection

D14	D15	Operation
1	0	Right channel
0	1	Left channel
1	1	L/R simultaneous

Treble control

D16	D17	D18	D19	Operation
1	0	1	0	+10 dB
0	0	1	0	+8 dB
1	1	0	0	+6 dB
0	1	0	0	+4 dB
1	0	0	0	+2 dB
0	0	0	0	0 dB
1	0	0	1	-2 dB
0	1	0	1	-4 dB
1	1	0	1	-6 dB
0	0	1	1	-8 dB
1	0	1	1	-10 dB

Bass control

(Mid control)

D20	D21	D22	D23	Operation
1	0	1	0	+10 dB
0	0	1	0	+8 dB
1	1	0	0	+6 dB
0	1	0	0	+4 dB
1	0	0	0	+2 dB
0	0	0	0	0 dB
1	0	0	1	-2 dB
0	1	0	1	-4 dB
1	1	0	1	-6 dB
0	0	1	1	-8 dB
1	0	1	1	-10 dB

Super bass control

(bass control)

* Control is possible only for 3-band specifications for the cut side (-)

D24	D25	D26	D27	Operation
1	0	1	0	+10 dB
0	0	1	0	+8 dB
1	1	0	0	+6 dB
0	1	0	0	+4 dB
1	0	0	0	+2 dB
0	0	0	0	0 dB
1	0	0	1	-2 dB
0	1	0	1	-4 dB
1	1	0	1	-6 dB
0	0	1	1	-8 dB
1	0	1	1	-10 dB

General-purpose op-amp specifications

(D28 to D31 fixed to 0)

D28	D29	D30	D31	Operation
0	0	0	0	

ATT control specifications

D28	D29	D29	D30	Operation
0	0	0	0	0 dB
1	0	0	0	-2 dB
0	1	0	0	-4 dB
1	1	0	0	-6 dB
0	0	1	0	-8 dB
1	0	1	0	-10 dB
0	1	1	0	-12 dB
1	1	1	0	-14 dB
0	0	0	1	-16 dB
1	0	0	1	-18 dB
0	1	0	1	-∞ dB

3-band specifications

(fixed to the values below)

(Switch all off)

D28	D29	D30	D31	Operation
1	1	0	1	

Pin Functions

Pin No.	Pin Name	Function	Equivalent circuit
18 17 16 15 14 20 21 22 23 24	L1 L2 L3 L4 L5 R1 R2 R3 R4 R5	• Input signal pins	
13 25	LSEL0 RSEL0	• Input selector output pins	
10 9 28 29 8 30	LBASS1 LBASS2 RBASS1 RBASS2 LSB RSB	• Capacitor and resistor connection pins for configuring filter, used for bass and super bass band, or for mid and bass	
7 31	LOUT ROUT	• ATT + equalizer output pins/capacitor connection pins used to configure super bass filter	
12 26	LVRIN RVRIN	• Volume input pins	
11 27	LTRE RTRE	• Capacitor connection pins for configuring treble band filter	

Continued on next page.

LC75343M

Continued from preceding page.

Pin No.	Pin Name	Function	Equivalent circuit
19	Vref	<ul style="list-style-type: none"> Connect a capacitor of a few tens of μF between Vref and AV_{SS} (V_{SS}) as a analog ground $0.5 \times V_{\text{DD}}$ voltage generator, current ripple countermeasure. 	
3	V _{SS}	<ul style="list-style-type: none"> Ground pin 	
35	V _{DD}	<ul style="list-style-type: none"> Power supply pin 	
2	CE	<ul style="list-style-type: none"> Chip enable pin Data is written to the internal latch and the analog switches are operated when the level changes from high to low. Data transfer is enabled when the level is high. 	
1 36	DI CL	<ul style="list-style-type: none"> Serial data pins and clock input pin for control 	
6 32	LINP RINP	<ul style="list-style-type: none"> General-purpose op-amp specifications Non-inverted input pins of general-purpose op-amp When not used, leave open. ATT control specifications Non-inverted input pins for ATT. 3-band specifications Non-inverted input pins for ATT. Always leave these pins open. 	
5 33	LINM RINM	<ul style="list-style-type: none"> General-purpose op-amp specifications Non-inverted input pins of general-purpose op-amp. When not used, connect these pins to the L(R) OPOUT pins. (Connected between pin 5 and pin 4) (Connected between pin 33 and pin 34) ATT control specifications Op-amp inverted input pins for ATT. Connected to L(R) OPOUT pins. (Connected between pin 5 and pin 4) (Connected between pin 33 and pin 34) 3-band specifications Inverted input pins of ATT op-amp. Connected to L(R) OPOUT pins. (Connected between pin 5 and pin 4) (Connected between pin 33 and pin 34) 	
4 34	LOPOUT ROPOUT	<ul style="list-style-type: none"> General-purpose op-amp specifications General-purpose op-amp output pins. When not used, connect these pins to the L(R) INM pins. (Connected between pin 5 and pin 4) (Connected between pin 33 and pin 34) ATT control specifications Op-amp output pins for ATT. Connected to L(R) INM pins. (Connected between pin 5 and pin 4) (Connected between pin 33 and pin 34) 3-band specifications ATT op-amp output pins. (Connected to L(R) INM pins. (Connected between pin 5 and pin 4) (Connected between pin 33 and pin 34) 	

Equivalent Circuit

- Selector Block/Reference Voltage Generator

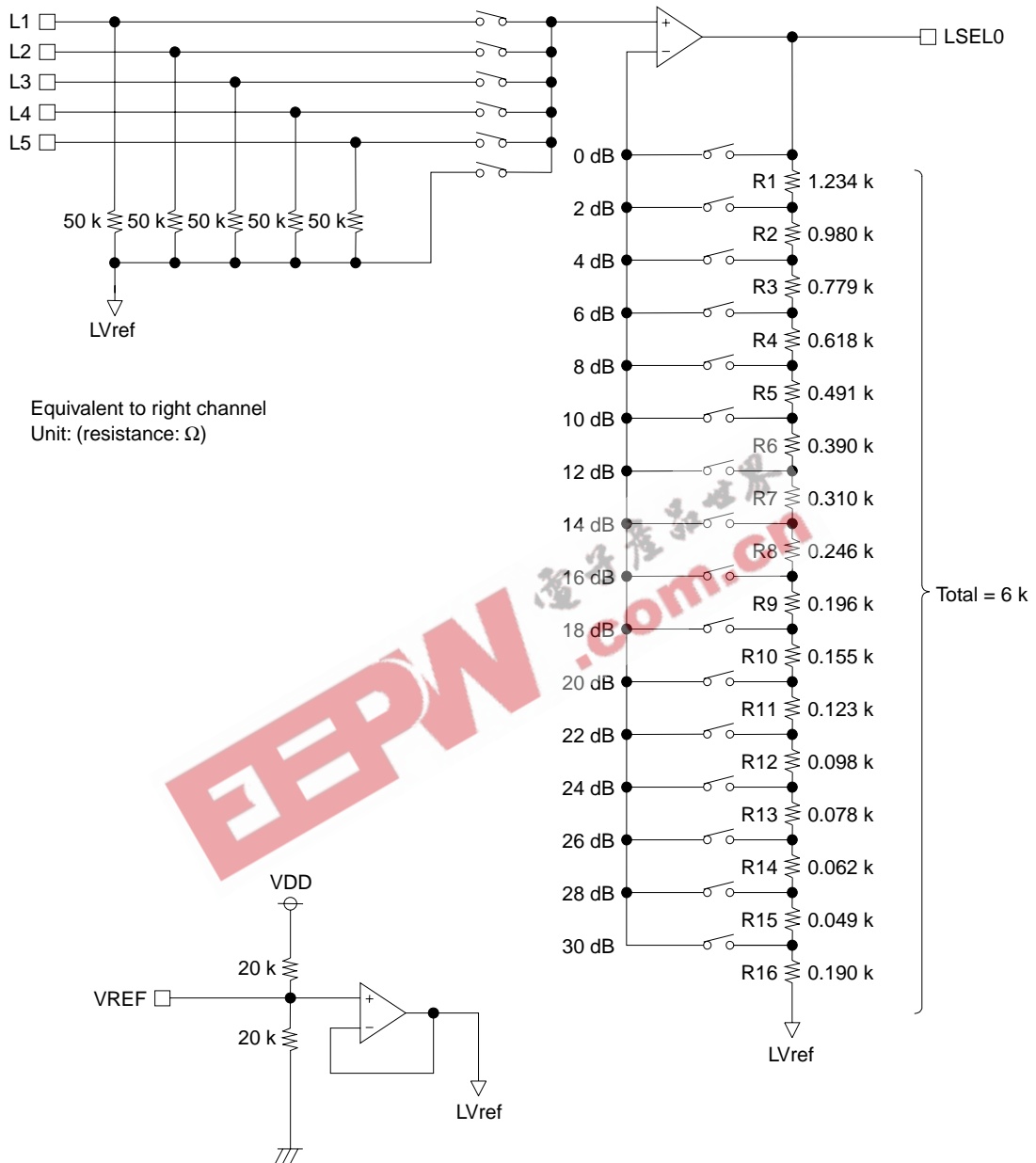

• Treble/Bass/Super Bass Band

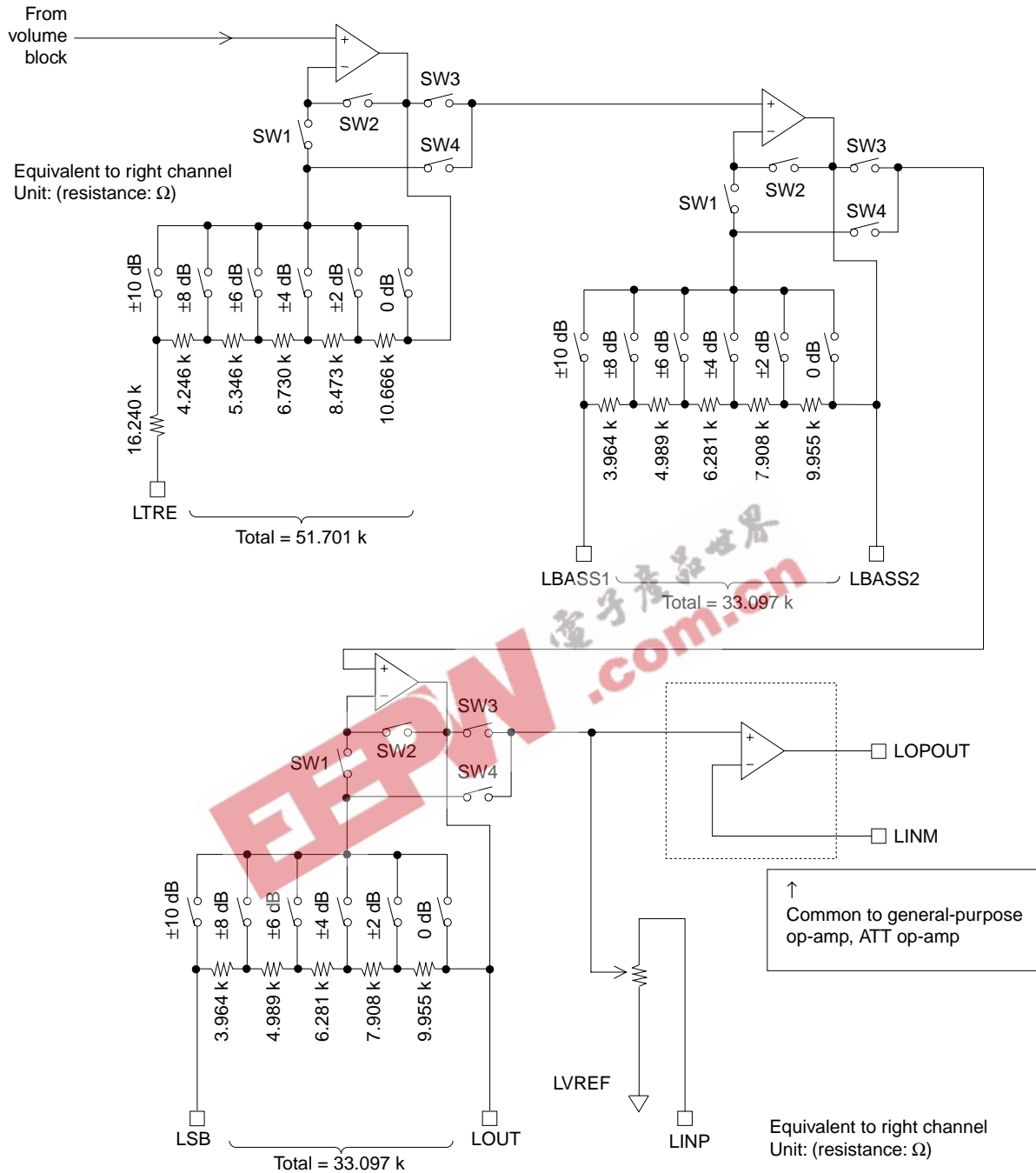

During boost, SW1 and SW3 are on, during cut, SW2 and SW4 are on, when 0 dB, 0dB SW and SW2 and SW3 are on.

For the super bass block:

- In case of general-purpose op-amp specifications, ATT control specifications (“0” set to D3)
SW3, SW4 are off, and only boost side operates (only SW1 is on).
- In case of 3-band specifications (“1” set to D3)
During boost, SW1 and SW3 are on, during cut, SW2 and SW4 are on, when 0 dB, 0dB SW and SW2 and SW3 are on.

LC75343M

• Volume Block

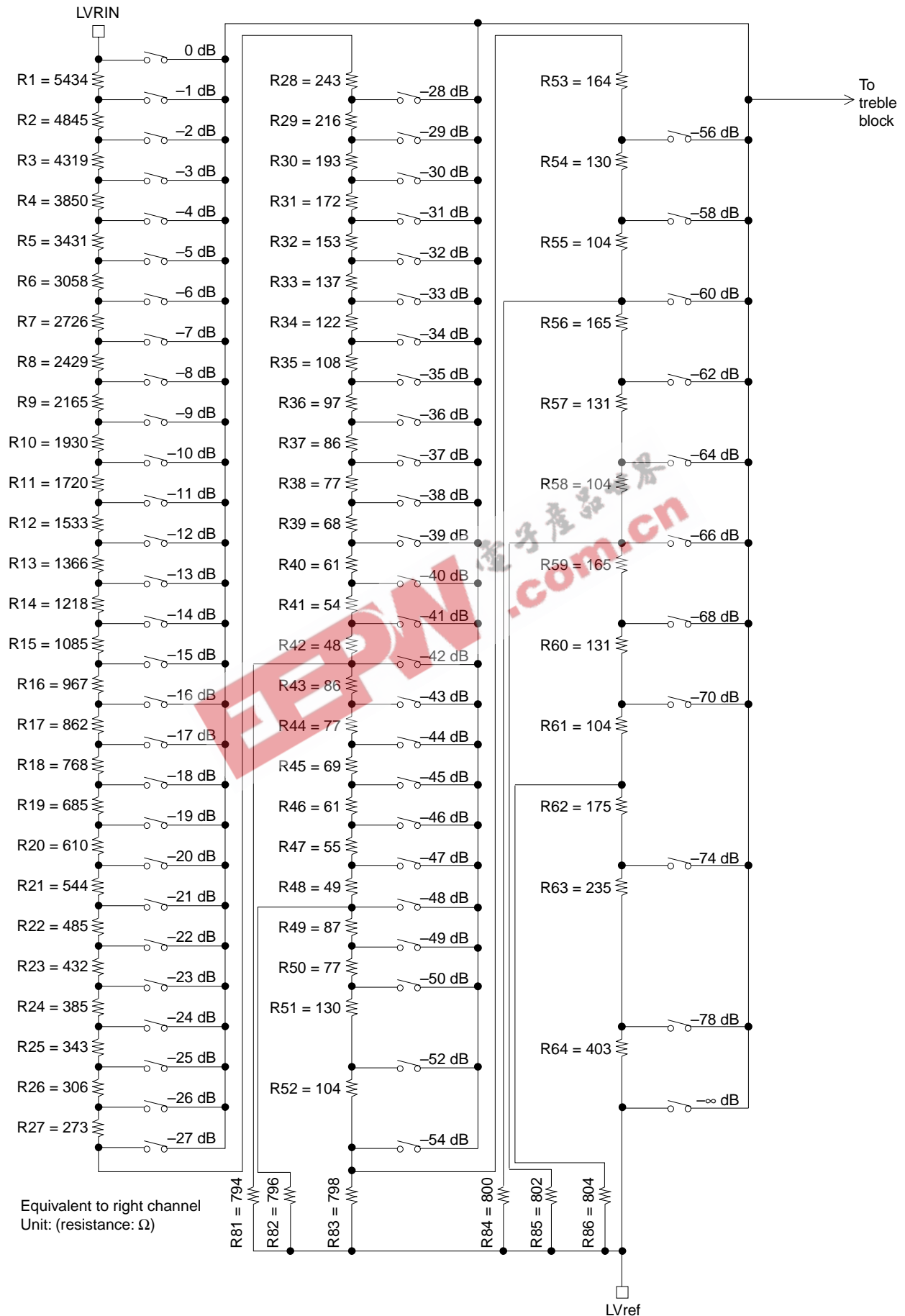

• ATT Block Equivalent Circuit
(during ATT control)

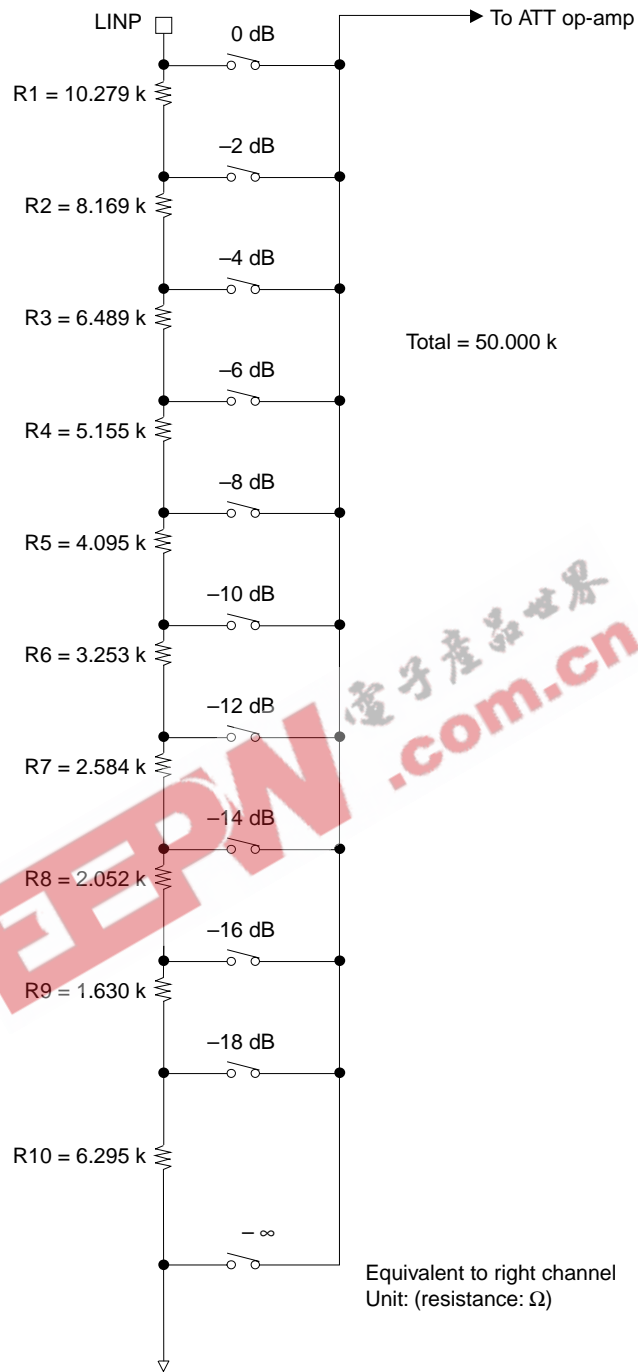

Test Circuit

General-Purpose Op-amp Specifications

- Total Harmonic Distortion

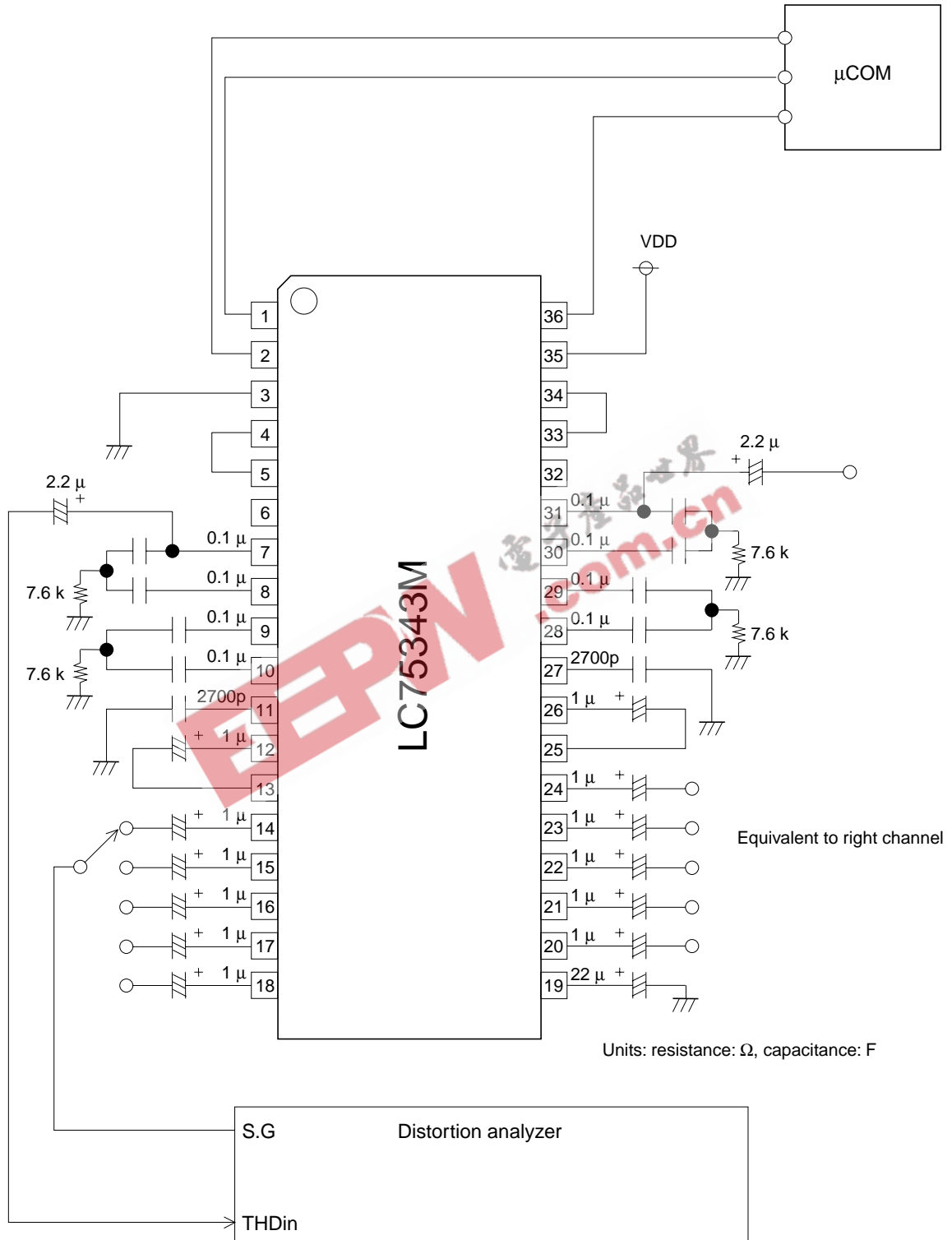

LC75343M

• Output Noise Voltage

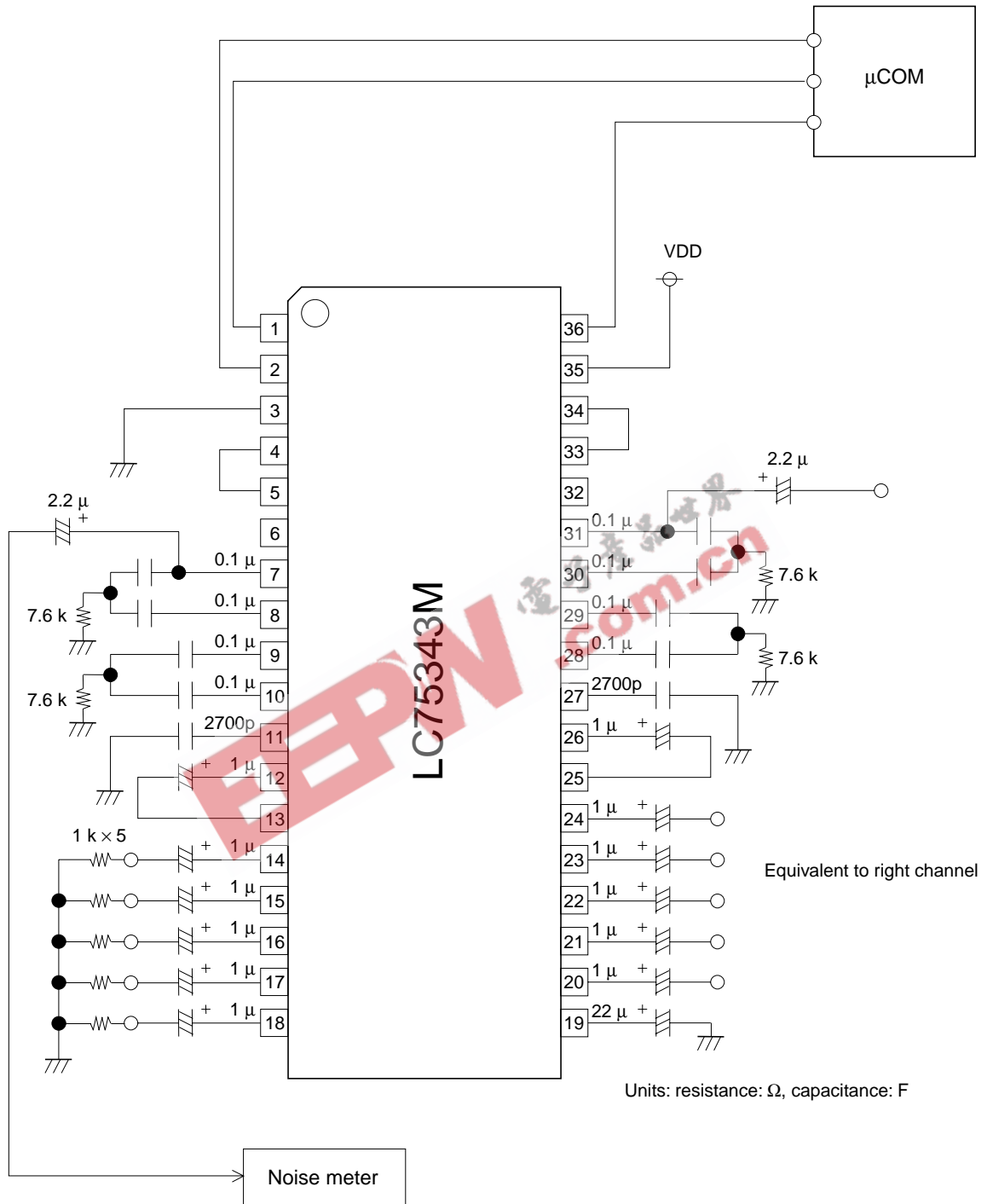

LC75343M

- Crosstalk

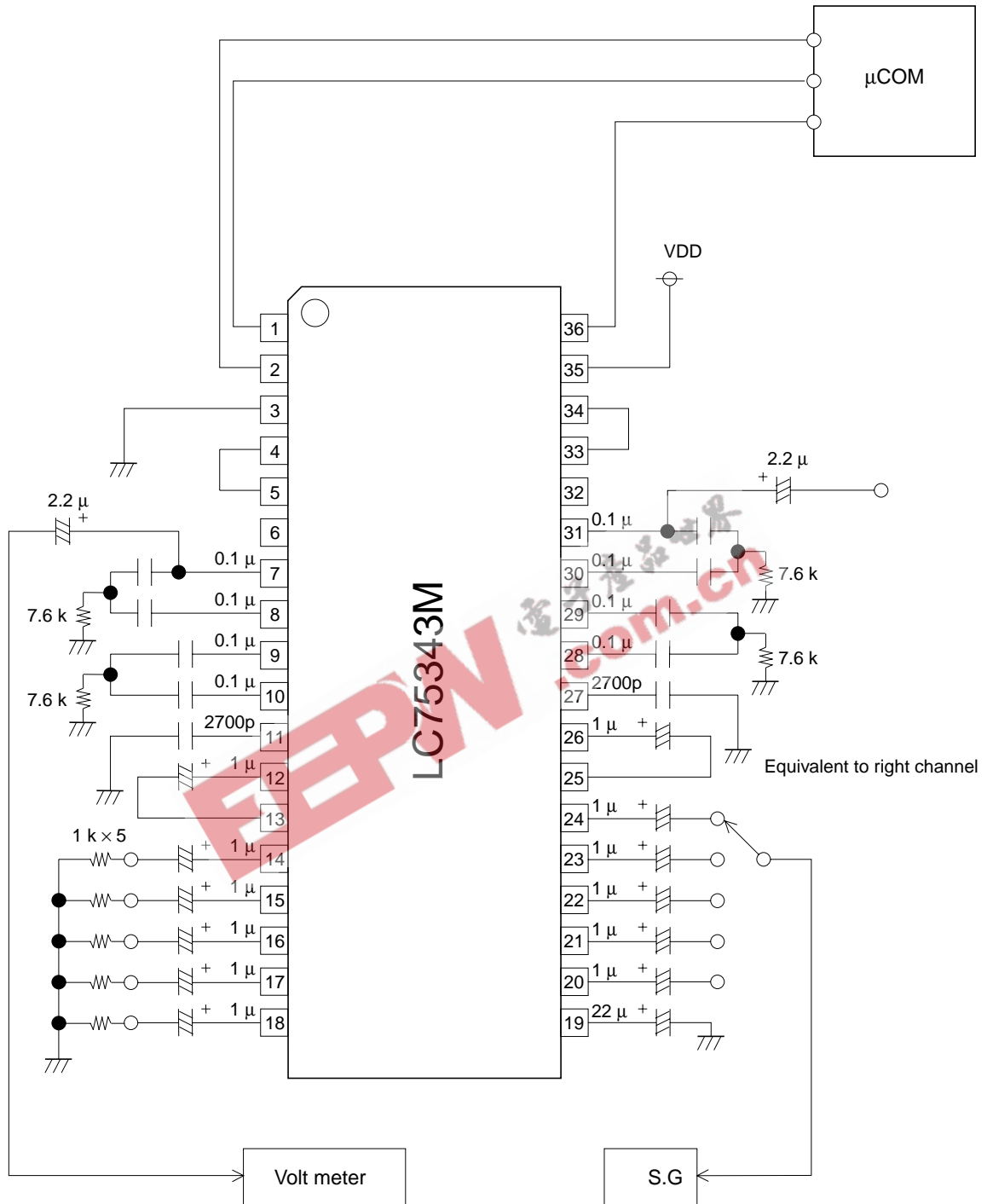

Units: resistance: Ω , capacitance: F

LC75343M

ATT Control Specifications and 3-Band Specifications

- Total Harmonic Distortion

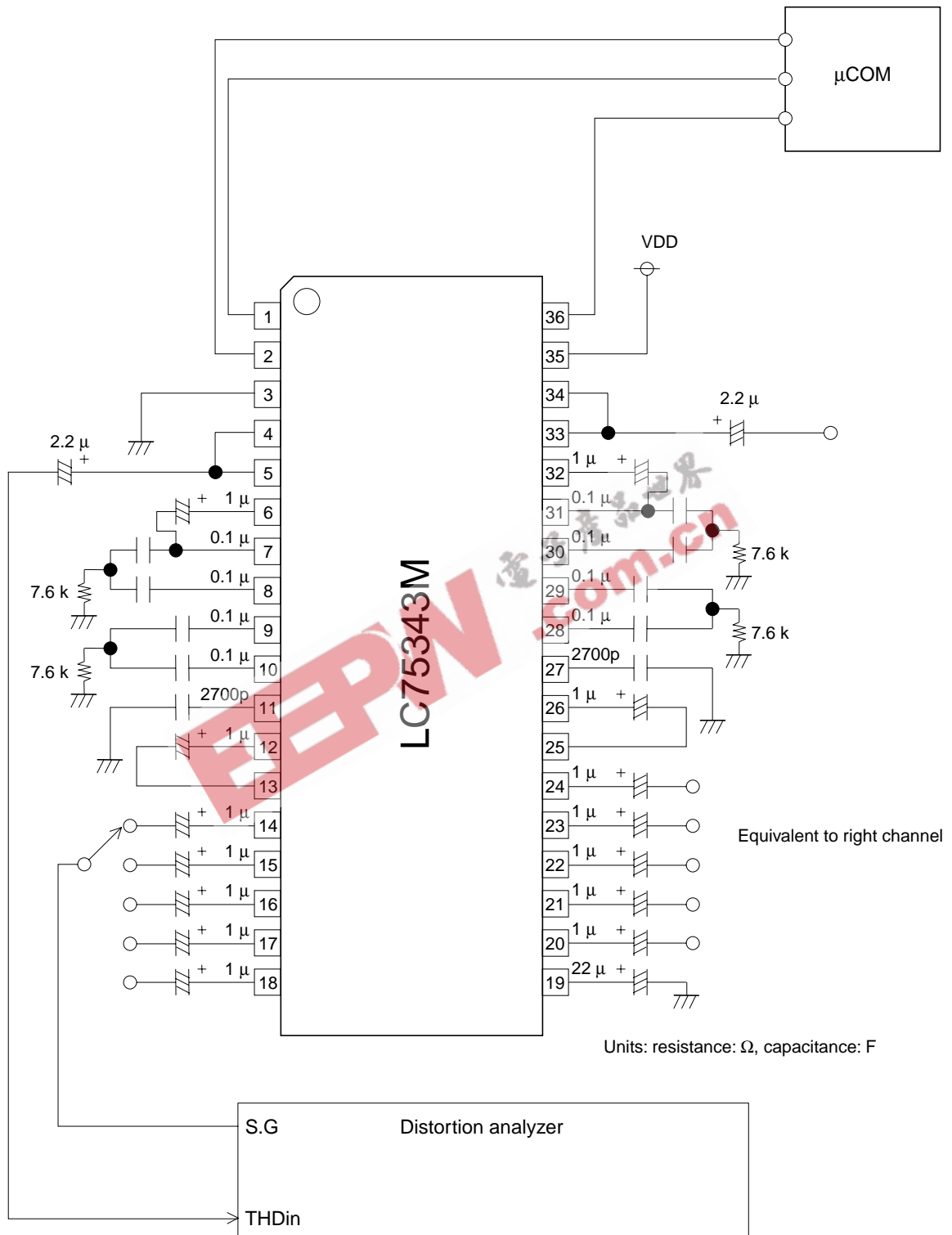

LC75343M

• Output Noise Voltage

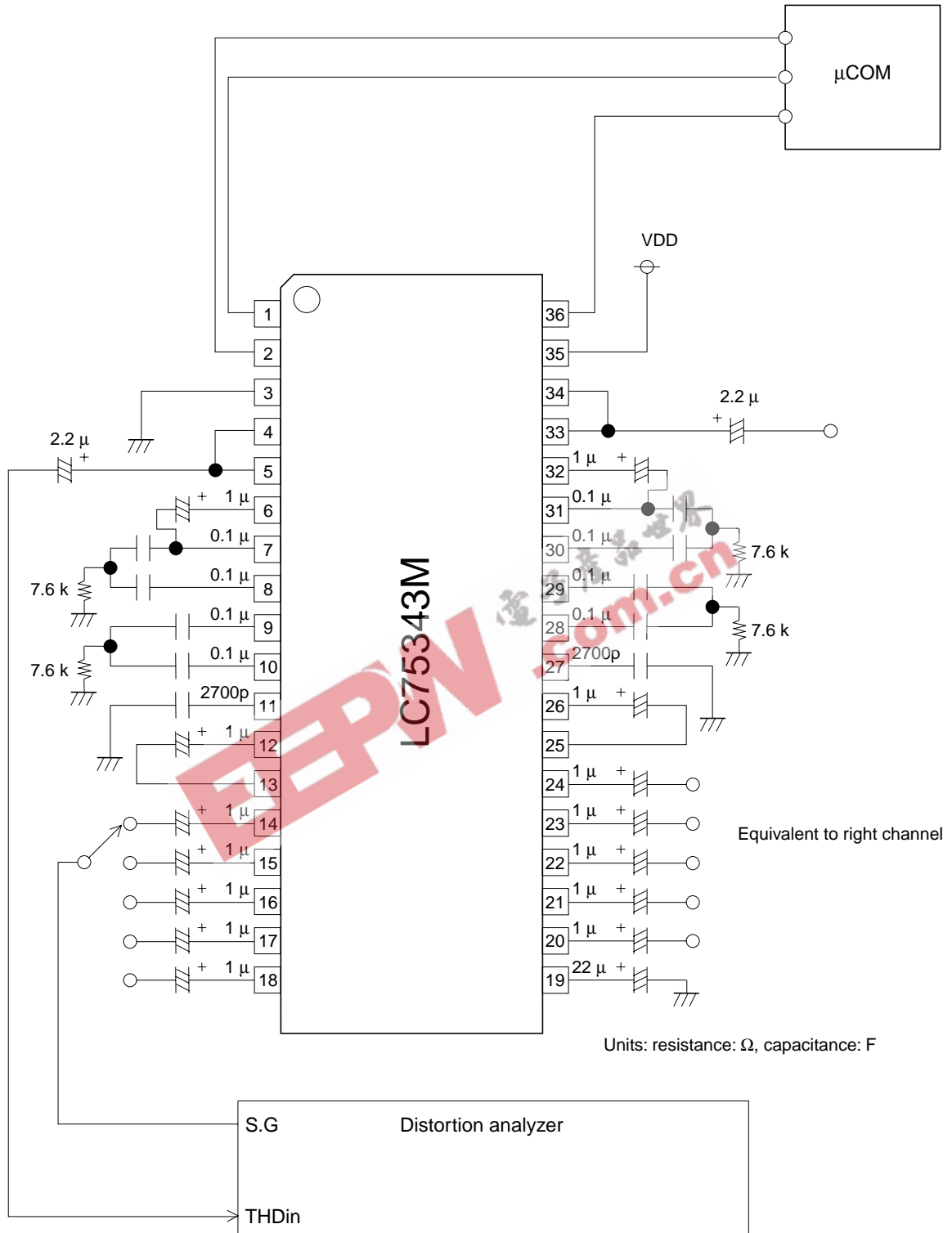

LC75343M

- Crosstalk

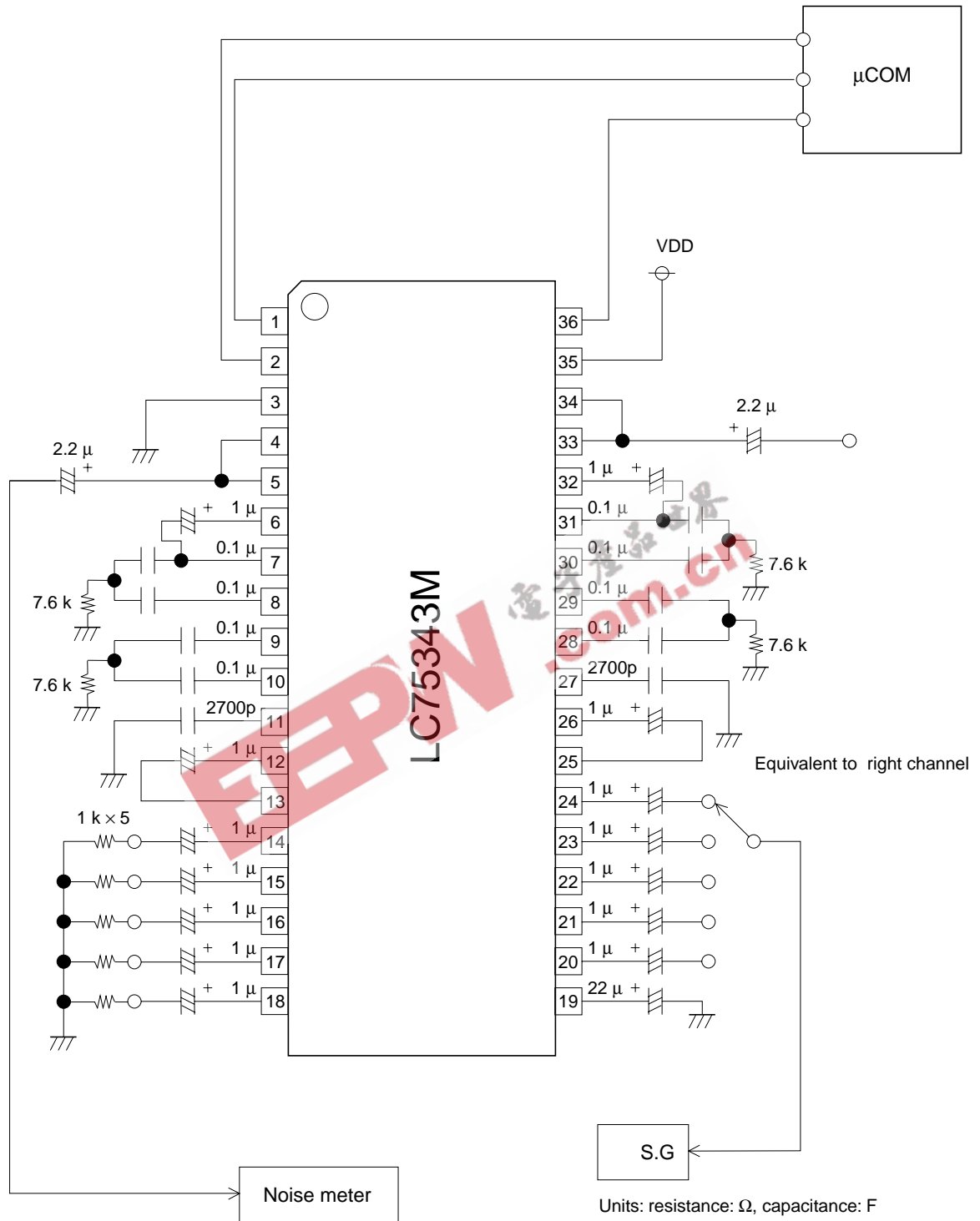

Calculation of External Equalizer Constant

Bass/Super Bass Circuit

The equivalent circuit and the formula for calculating the external RC with a mean frequency of 1000 Hz are shown below.

- Bass/super bass band equivalent circuit block diagram

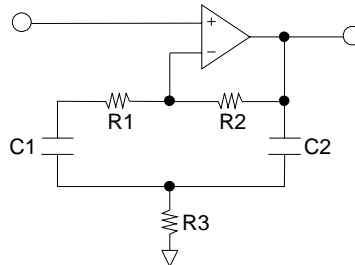

- Calculation example

Specification Mean frequency: $f_0 = 1000 \text{ Hz}$

Gain during maximum boost: $G = 10 \text{ dB}$

Using $R_1 = 0$, $R_2 = 33.097 \text{ k}\Omega$, and $C_1 = C_2 = C$,

We obtain R_2 from $G = 10 \text{ dB}$.

$$G_{+10 \text{ dB}} = 20 \times \text{LOG}_{10} \left(1 + \frac{R_2}{2R_3} \right)$$

$$R_3 = \frac{R_2}{2(10^{G/20} - 1)} = \frac{33097}{2 \times (3.162 - 1)} \approx 7.6 \text{ K}\Omega$$

We obtain C from mean frequency $f_0 = 1000 \text{ Hz}$.

$$f_0 = \frac{1}{2\pi\sqrt{R_3R_2C_1C_2}}$$

$$C = \frac{1}{2\pi f_0 \sqrt{R_3R_2}} = \frac{1}{2\pi \times 1000 \sqrt{33097 \times 7600}} \approx 0.01 \mu\text{F}$$

We obtain Q .

$$Q = \frac{R_3R_2}{2R_3} \frac{1}{\sqrt{R_3R_2}} \approx 1.04$$

Treble Band Circuit

The shelving characteristics can be obtained for the treble band.

The equivalent circuit and calculation formula during boost are indicated below.

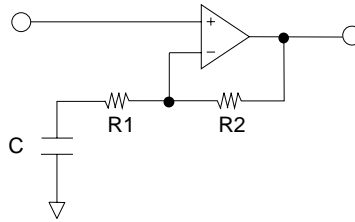

• Calculation example

Specification Set frequency: $f = 26000 \text{ Hz}$

Gain during maximum boost: $G_{+10 \text{ dB}} = 10 \text{ dB}$

Using $R1 = 16.240 \text{ k}\Omega$ and $R2 = 35.461 \text{ k}\Omega$, and inserting the above values in the following formula, we obtain:

$$G = 20 \times \text{LOG}_{10} \left(1 + \frac{R2}{\sqrt{R1^2 + (1 / \omega C)^2}} \right)$$

$$C = \frac{1}{2\pi f \sqrt{\left(\frac{R2}{10^{G/20} - 1}\right)^2 - R1^2}}$$

$$= \frac{1}{2\pi 26000 \sqrt{\left(\frac{35461}{3.16-1}\right)^2 - 16240^2}} \approx 2700(\text{pF})$$

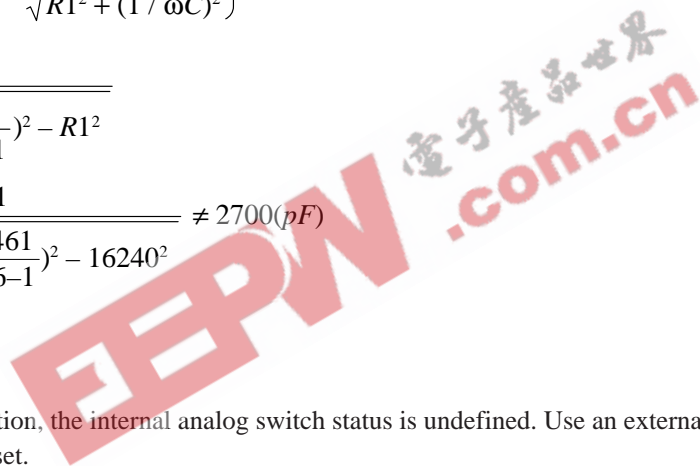

Usage Cautions

- Upon power application, the internal analog switch status is undefined. Use an external countermeasure such as muting until data is set.
- When performing initial setting after applying power, send the initial setting data for the left and right channels prior to canceling mute.
- To ensure that the high-frequency digital signals sent to the CL, DI, and CE pins do not spill over to the analog signal block, either guard these signal lines with a ground pattern, or perform transmission using shielded wires.

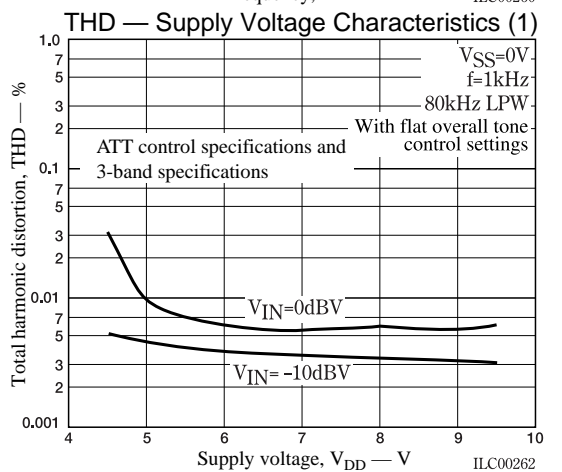
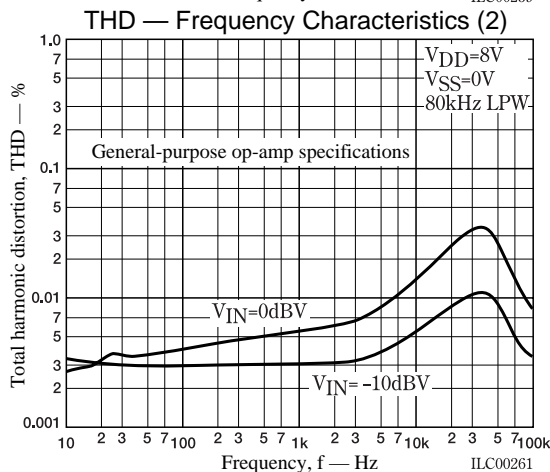
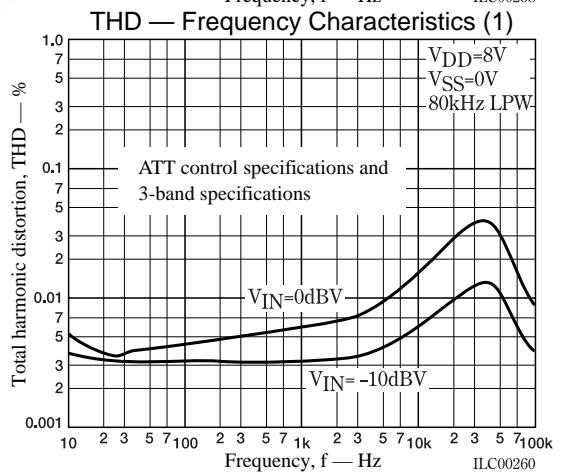
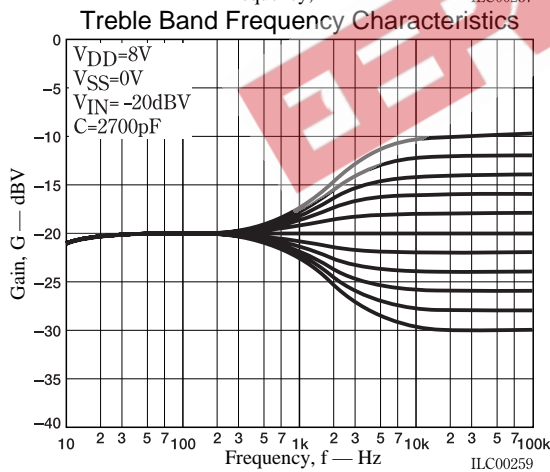
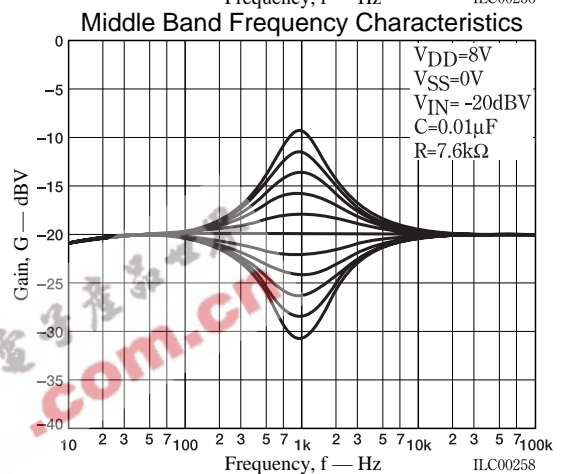
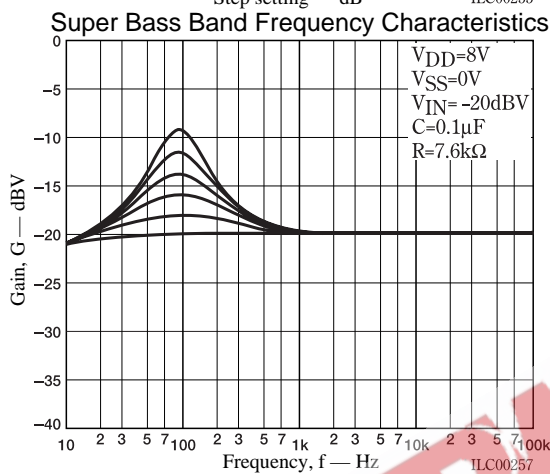
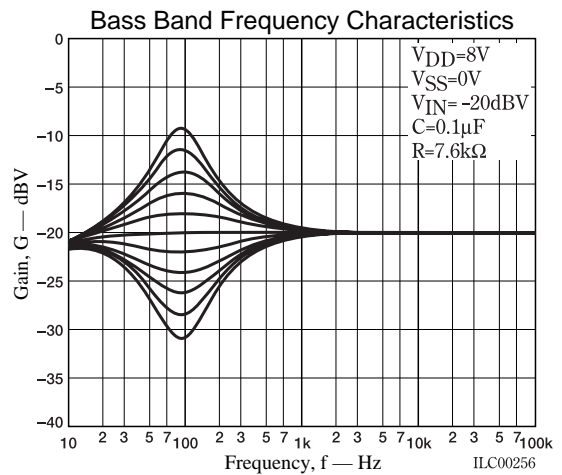
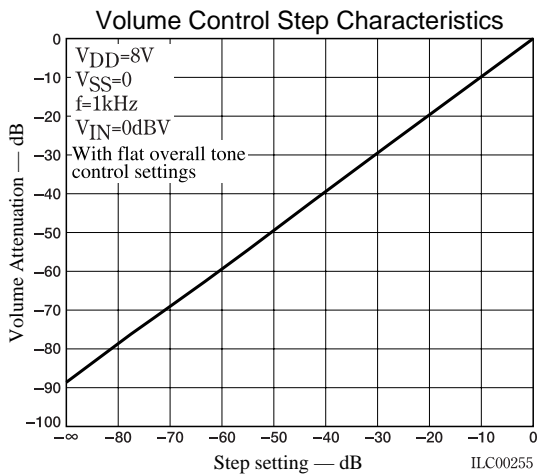

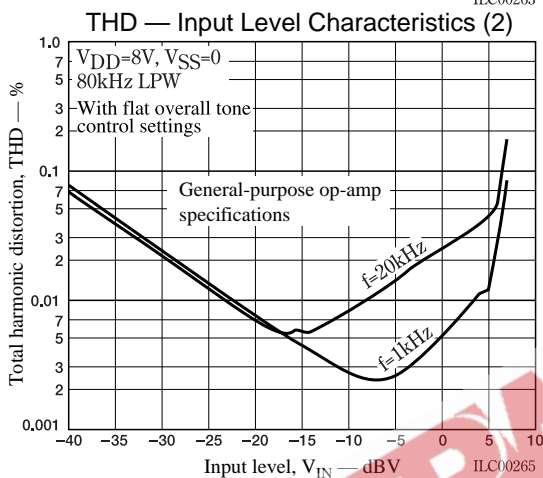
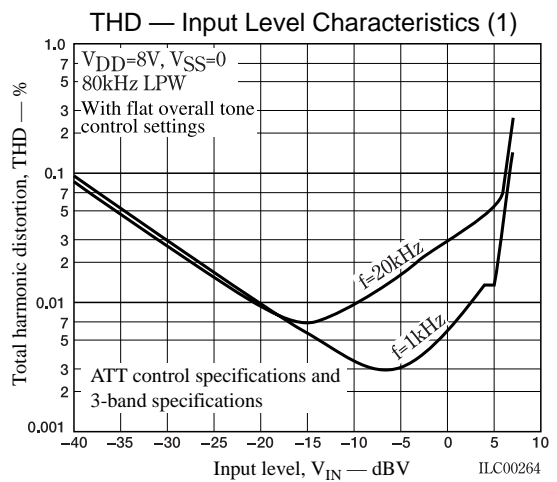
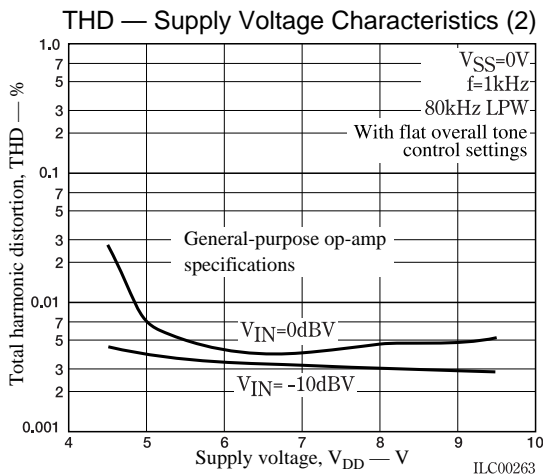

- Specifications of any and all SANYO products described or contained herein stipulate the performance, characteristics, and functions of the described products in the independent state, and are not guarantees of the performance, characteristics, and functions of the described products as mounted in the customer's products or equipment. To verify symptoms and states that cannot be evaluated in an independent device, the customer should always evaluate and test devices mounted in the customer's products or equipment.
- SANYO Electric Co., Ltd. strives to supply high-quality high-reliability products. However, any and all semiconductor products fail with some probability. It is possible that these probabilistic failures could give rise to accidents or events that could endanger human lives, that could give rise to smoke or fire, or that could cause damage to other property. When designing equipment, adopt safety measures so that these kinds of accidents or events cannot occur. Such measures include but are not limited to protective circuits and error prevention circuits for safe design, redundant design, and structural design.
- In the event that any or all SANYO products (including technical data, services) described or contained herein are controlled under any of applicable local export control laws and regulations, such products must not be exported without obtaining the export license from the authorities concerned in accordance with the above law.
- No part of this publication may be reproduced or transmitted in any form or by any means, electronic or mechanical, including photocopying and recording, or any information storage or retrieval system, or otherwise, without the prior written permission of SANYO Electric Co., Ltd.
- Any and all information described or contained herein are subject to change without notice due to product/technology improvement, etc. When designing equipment, refer to the "Delivery Specification" for the SANYO product that you intend to use.
- Information (including circuit diagrams and circuit parameters) herein is for example only; it is not guaranteed for volume production. SANYO believes information herein is accurate and reliable, but no guarantees are made or implied regarding its use or any infringements of intellectual property rights or other rights of third parties.

This catalog provides information as of February, 2001. Specifications and information herein are subject to change without notice.